

SSP5800 Inverter booster pump **SSP5800**



User Manual - EN

1	NO	Function description	Setting range	Factory setting	R	S	
Main frequency source	P0	Main frequency input source setting	0 : main frequency input controlled by digital operator 1 : AV0:knob in digital operator 2 : AV1:analog signal 0~10V input (AVI) 3 : AV2:analog signal 4~20mA input (ACI) 4 : main frequency communication input (RS485) 5 : high frequency pulse input(HDI)	0	×	✓	
			6 : water supply mode				
Operating function setting	P1	Operating signal source setting	0 : operating command controlled by digital operator 1 : operating command controlled by external terminals,stop key works 2 : operating command controlled by external terminals,stop key disabled 3 : operating command controlled by communication input, stop key works 4 : operating command controlled by communication input, stop key disabled	0	×	✓	
	P2	Power activation lock setting	0 : operable 1 : inoperable	0	×	✓	
	P3	Motor braking setting	0 : stop by deceleration braking 1 : stop by free operation	0	×	✓	
	P4	DC braking current level	0.0~100.0 % , 『 limited to 1.25 times of motor rated current 』	0.0	✓	✓	
	P5	DC braking time setting in start up	0.0~25.0 s	0.0	×	✓	
	P6	DC braking time setting in stop	0.0~25.0 s	0.0	×	✓	
	P7	DC braking initial frequency in stop	0.00~60.00 Hz, 『 only work in V/F mode 』	0.00	×	✓	
Voltage/frequency curve setting	P8	Maximum voltage frequency option	10.00~400.0Hz	50.00	60.00	×	✓
	P9	Maximum output voltage option	230V : 0.1~250.0V 460V : 0.1~500.0V	220.0 380.0	×	✓	
	P10	Intermediate frequency option	0.10~400.0Hz	1.50	×	✓	
	P11	Intermediate voltage option	230V : 0.1~250.0 V 460V : 0.1~500.0V	10.0 17.3	×	✓	
	P12	Minimum output frequency	0.10~20.00 Hz	1.50	×	✓	
	P13	Minimum output voltage	230V : 0.1~250.0 V 460V : 0.1~500.0V	10.0 17.3	×	✓	
	 P12 ≤ P10 ≤ P8 ; P10~P13 is applied to V/F mode only , vector mode is disabled.						
	P14	VF second and third point curve rate	0.0~100.0%	0.0	×	✓	
	0.0% : straight line ; 37.5% : 1.3 power; 78.5% : 1.7 power; 100.0% : 2.0power;						
Accel/decel time setting	P15	First acceleration time option	0.01~600.0 s	10.00	✓	✓	
	P16	First deceleration time option	0.01~600.0 s	10.00	✓	✓	
	P17	Second acceleration time option	0.01~600.0 s	10.00	✓	✓	
	P18	Second deceleration time option	0.01~600.0 s	10.00	✓	✓	
	P19	Inching accel/decel time	0.01~600.0 s	1.00	✓	✓	
	P20	First/second acceleration frequency auto switching time point	0.00 : this function disabled 0.00~400.00 Hz	0.00	✓	✓	

	P21	First/second deceleration frequency auto switching time point	0.00 : this function disabled 0.00~400.00 Hz	0.00	✓	✓
	P22	Acceleration S curve setting	0.0~100.0 ; 『only work for frequency commandP27~P36』	0.0	✓	✓
	P23	Deceleration S curve setting	0.0~100.0 ; 『only work for frequency commandP27~P3』	0.0	✓	✓
Frequency command setting	P24	Reverse prohibition setting	0 : reversible 1 : reverse prohibition	0	×	✓
	P25	Output frequency lower limit	0.00~400.0 Hz	0.00	×	✓
	P26	Output frequency upper limit	0.10~400.0 Hz ≤ 8 × P118	50.00 60.00	×	✓
	P27	Main frequency setting of digital operator	0.00~400.0 Hz	50.00 60.00	✓	✓
	P28	First bank frequency setting	0.00~400.0 Hz	5.00	✓	✓
	P29	Second bank frequency setting	0.00~400.0 Hz	10.00	✓	✓
	P30	Third bank frequency setting	0.00~400.0 Hz	20.00	✓	✓
	P31	Forth bank frequency setting	0.00~400.0 Hz	30.00	✓	✓
	P32	Fifth bank frequency setting	0.00~400.0 Hz	40.00	✓	✓
	P33	Sixth bank frequency setting	0.00~400.0 Hz	50.00	✓	✓
	P34	Seventh bank frequency setting	0.00~400.0 Hz	60.00	✓	✓
	P35	Inching frequency setting	0.00~400.0 Hz	0.00	✓	✓
	P36	Communication main frequency setting	0.00~400.0 Hz	0.00	✓	✓

2	NO	Function description	Setting range	Factory setting	R	S
	P37	Prohibition setting frequency 1	0.00~400.0 Hz	0.00	×	✓
	P38	Prohibition setting frequency 2	0.00~400.0 Hz	0.00	×	✓
	P39	Prohibition setting frequency 3	0.00~400.0 Hz	0.00	×	✓
	P40	Prohibition frequency width setting	0.00~20.00 Hz	0.00	×	✓
	P41	Disturbance hopping frequency	0.00~400.0Hz	0.00	×	✓
	P42	Disturbance hopping width	0.00~400.0Hz	0.00	×	✓
Analog input setting	P43	AVI : 0 V input	-200.0% ~200.0%	0	✓	✓
	P44	AVI : 10 V input	-200.0% ~200.0%	100.0	✓	✓
	P45	AVI input digital filter	0~9999ms= 4 * τ => τ :0~2.5 s	50	✓	✓
	P46	ACI : 4 mA input	-200.0% ~200.0%	0	✓	✓
	P47	ACI : 20 mA V input	-200.0% ~200.0%	100.0	✓	✓
	P48	ACI input digital filter	0~9999ms	50	✓	✓
	P49	ACI disconnection handling	0 : Deceleration to 0Hz 1 : free stop immediately and display "EF"	0	×	✓
	P50	Reverse setting in negative bias	0 : Non-reversible in negative bias 1 : Reversible in negative bias(Forward/reverse will be decided by the positive/negative of itself)	0	×	✓

Analog output	P51	Analog output signal setting 1	0 : analog frequency meter(0 to the upper limit of the output frequency) 1 : analog ampere meter(0 to 250% rated current) 2 : feedback signal output (0-100%) 3 : output power (0-100%) 4 : internal variables(P84)/ P84	0	✓	✓	
	P52	Analog output 1 gain setting	0.0~200.0 %	100.0	✓	✓	
Multi function digital input	P53	External terminal scanning time setting	1~100 ms	1	✓	✓	
	P54	Digital input logic setting	0~511 : NO set as 0 , NC set as 1	0	×	✓	
	Eg : if M5,M2 are NC , others are NO , then setting value =000100100b=2^5+2^2=36						
	P55	Function option of multi-function input terminal (M0) Function option of multi-function input terminal(M1)	0 : M0 : Forward/stop ; M1 : Reverse/stop 1 : M0 : Operation/stop ; M1 : Reverse/Forward 2 : three-line operation M0(operation) 、 M1(reverse/forward) 、 M2(stop)	0	×	✓	
	P56	Function option of multi-function input terminal(M2)	0 : no function 1 : operation allowable (N.O.) 2 : operation allowable (N.C.) 3 : E.F.external abnormal input (N.O) 4 : E.F.external abnormal input (N.C) 5 : RESET clear command (N.O.) 6 : RESET clear command (N.C)	5	×	✓	
	P57	Function option of multi-function input terminal(M3)	7 : Multi-section speed command 1 8 : Multi-section speed command 2 9 : Multi-section speed command 3	7	×	✓	
	P58	Function option of multi-function input terminal(M4)	10 : inching operation 11 : Acceleration and deceleration prohibition command 12 : first/second acceleration/deceleration time switch 13 : B.B.external interruption (N.O) 14 : B.B.external interruption (N.C) 15 : Up frequency increase command 16 : Down frequency decrease command 17 : AUTO RUN programmable auto run(stop key works) 18 : PLC click auto run (stop key works) 19 : PAUSE Pause auto run 20 : Counter trigger signal input (priority > 31) 21 : counter clear 22 : external terminal as enforced operation command source 23 : digital operator as enforced operation command source 24 : communication terminal as enforced operation command source 25 : parameter locked 26 : PID function disabled (N.O) 27 : PID function disabled (N.C) 28 : activate second frequency source 29 : enforced forward (contacts Open) /reverse (Close) 30 : simple positioning zero point signal input 31 : virtual counter input function 32 : inching forward 33 : inching reverse	8	×	✓	
P59	Function option of multi-function input terminal(M5) P56 、 P57 、 P58 、 P59 cannot be set repeatedly (except for 0)		9	×	✓		

3	NO	Function description	Setting range	Factory setting	R	S
Multi-function digital input			34 : Manual polled command 35 : Manual soft start debugging 36 : motor A manual soft start 37 : motor B manual soft start 38 : motor C manual soft start 39 : motor D manual soft start 40 : Reserve 41 : Reserve 42 : Reserve 43 : motor A disabled 44 : motor B disabled 45 : motor C disabled 46 : motor D disabled 47 : Motor E disabled 48 : motor F disabled 49 : Motor G disabled 50 : suction sump water level over upper limit 51 : suction sump water level over down limit 52 : suction sump water level over water shortage level 53 : sewage pool water level over upper limit 54 : sewage pool water level over down limit			
	P60	External UP/Down acceleration/deceleration mode	0 : by fixed mode (such as digital operator) 1 : by acceleration/deceleration time	0	✓	✓
	P61	Second frequency command source	0 : main frequency input controlled by digital operator 1 : AV0:knob in digital operator 2 : AV1:analog signal 0~10V input (AVI) 3 : AV2: analog signal 4~20mA input (ACI) 4 : main frequency communication input (RS485) 5 : high frequency pulse input (HDI)	0	✓	✓
Automatic positoning	P62	Motor shaft/machine shaft deceleration ratio	4~1600	200	×	✓
	P63	Machine shaft auto positioning angle setting	0.0~360.0	180.0	×	✓
	P64	Auto positioning deceleration time	0.00auto positioning function disabled 0.01~100.00s	0.00	×	✓
Multi-function	P65	Multi-function output terminal (MO1)	0 : Operation indication 1 : set frequency reach indication	0	×	✓

output	P66	Multi-function output RELAY1 contacts	2 : zero-speed indication 3 : over torque indication 4 : External interruption indication (B.B.) 5 : low voltage detected indication (220.0 / 440.0 V) 6 : indication for external terminal as operation command source 7 : faults indication 8 : any frequency reach indication 9 : program operation indication 10 : phase completion indication 11 : program completion indication 12 : program pause indication 13 : set counting value reach indication (Period) 14 : designated counting value reach indication (Cmp) 15 : warning (PID feedback signal abnormal FbE , communication abnormal Cexx) 16 : reach indication if lower than any frequency 17 : PID deviation beyond the set range 18 : warning before OV (P71-10.0 V) 19 : warning before OH (75.0 oC) 20 : OC stalling warning 21 : OV stalling warning 22 : Forward command indication 23 : Reverse command indication 24 : zero speed (including stop state) 25 : BRAKE control output 26~30 : reserve	7	×	✓
			31 : over voltage indication 32 : Low voltage indication 33 : Dormancy operation indication 34 : spare pressure operation indication 35 : water lacking indication 36 : faulty pump indication			

4	NO	Function description	Setting range	Factory setting	R	S
	P67	Any frequency reach setting	0.00~400.00 Hz	0.00	×	✓
	P68	Set counting value reach setting (Period)	0~9999	0	×	✓
	P69	Designated counting value reach setting(Cmp)	0~9999	0	×	✓
	P70	Handling after counter reach (Period)	0 : go on operation 1 : free braking and display E.F.	0	×	✓
	P71	DC-bus braking level	230V : 370.0~450.0 Vdc 460V : 740.0~900.0 Vdc	380.0 760.0	×	✓
	P72	Motor stalling prevention option	0 : over-current detection level in acceleration 230V : 330.0~450.0 Vdc 460V : 660.0~900.0 Vdc	390.0 780.0	×	✓
	P73	Over-current detection level in acceleration	0 : this function disabled 20.0~200.0 %	150.0	×	✓
	P74	Over-current detection level in operation	0 : this function disabled 20.0~200.0 % 『acceleration/deceleration=3.0 sec』	150.0	×	✓

	P75	Over torque detection option	0 : no detection for over torque 1 : over torque detection at fixed speed operation and go on operation after detection 2 : over torque detection at fixed speed operation and stop operation after detection 3 : over torque detection in operation, and (oL2) go on operation after detection 4 : over torque detection in operation, and (oL2) stop operation after detection	0	×	✓
	P76	Over torque detection level	30.0~200.0 %	150.0	×	✓
	P77	Over torque detection time	0.01~10.00 s	0.10	×	✓
Momentary power loss	P78	Operation option for momentary power loss	0 : stop operation after momentary power loss 1 : free operation after momentary power loss	0	×	✓
	P79	Max allowable time for power loss	0.3~5.0 s	2.0	×	✓
	P80	Speed tracking b.b time	0.4~25.0 s	0.5	×	✓
	P81	Max current for speed tracking	30.0~200.0 % , 『 limited to 2.5 times of motor rated current 』	150.0	×	✓
	P82	Initial display screen option	0 : display frequency(F) 1 : display parameter setting (P) 2 : display motor running frequency (H) 3 : display motor running current (A) A 4 : display forward/reverse 5 : display monitor variables	0		
	P83	Monitor variable option	0~30	1	✓	✓
		<p>0 : display physical quantity as output frequency (U) H*P84</p> <p>1 : display output voltage (E)</p> <p>2 : display main circuit DC voltage (u)</p> <p>3 : display PID command value</p> <p>4 : display PID feedback</p> <p>5 : display counting value(c)</p> <p>6 : display program operation (x sections .xxx times)</p> <p>7 : display motor U phase operation current (A)</p> <p>8 : display motor V phase operation current (A)</p> <p>9 : display motor W phase operation current (A)</p> <p>10 : display temperature (t)</p> <p>11 : DO_DI</p> <p>12 : AV0 knob in digital operator (%)</p> <p>13 : AVI analog signal 0~10V input (%)</p> <p>14 : ACI analog 4~20mA input (%)</p> <p>15 : HDI input (%)</p> <p>16: internal variables divided by 10 quotient</p> <p>17: internal variables divided by 10 remainder</p> <p>18 : AI3 analog signal -10~10V input (%)</p> <p>19 : AI4 analog signal 0~10V /4~20mA input (%)</p> <p>20 : DO08</p> <p>21 : current time(hour.mins)</p> <p>22 : current time(mins.secs)</p> <p>23 : output frequency when faulty occur</p> <p>24 : DC voltage when faulty occur</p> <p>25 : output voltage when faulty occur</p> <p>26 : output current when faulty occur</p> <p>27 : software version (12.05)</p> <p>28~30 : reserve</p>				
		11 : DO_DI Input M8,M7,M4,M1 and COM short circuit ; output RA1and RC1short circuit ; output MO2 and MC2 short circuit;				
		20 : DO08 RT5,RT3 and RT0 operation				

	P84	Proportional constant setting	0.01~160.0	1.00	✓	✓
	P85	Display internal variable address	512~2687	512	✓	✓
5	NO	Function description	Setting range	Factory setting	R	S
Abnormal records	P86	Latest abnormal record	0 : no abnormal records 1 : over voltage(ou) : Vdc > 1.84*V_RST (405V) 2 : low voltage (Lu) : Vdc < 1.0 * V_RST (220V) 3 : current in acceleration exceeds two times of rated current (ocA) 4 : current in deceleration exceeds two times of rated current (ocd) 5 : current at constant speed exceeds two times of rated current (ocn) 6 : over load(oL) : current > P133 , time > 60 sec 7 : over load 1 (oL1) : electronic heating relay motion 8 : over load 2 (oL2) : current > P76 , time > P77 9 : grounding protection or DC ripple current (GFF) 10 : over heat (oH) : over 90.0 oC , free stop ° Over heat forecast (oH0) : over 85.0 oC , go on operation ° 11 : protection line abnormal (EPrt) 12 : external abnormal (EF) 13 : external interruption allowed (bb) 14 : three phase output current unbalanced (ocbE) : amplitude error > 15% 15 : remains 16 : parameter auto detection failure(AutF) 17 : U phase current sensor abnormal (ct1E) 18 : W phase current sensor abnormal (ct2E) 19 : parameter reading error (ErP0) 20 : parameter setting error 1(ErP1) : P8 ≥ P10 ≥ P12 , P26 ≥ P25 21 : parameter setting error 2(ErP2) : P56~P59 repeated set 22 : software protection activated(codE) 23~30 : remains	0	×	✓
	P87	Last abnormal record		0	×	✓
	P88	Last two abnormal records		0	×	✓
	P89	Auto reset/start frequency after faults		0~10 (※for oc or ou only)	0	×
	P90	Faults restart auto restoration time	0.1~6000.0 s	60.0	×	✓
	P91	Faults restart option	0 : zero speed tracking from 0HZ 1 : free operation	1	×	✓
	P92	Parameter lock/reset setting	0 : all parameters set to be writable /readable 1 : all parameters set to be read only 2 : keyboard locked 3 : all parameters set to be factory setting of 50Hz 4 : all parameters set to be factory setting of 60Hz 5 : clear abnormal records	0	×	✓
	P93	Storage setting frequency option	0 : no memory of the frequency before power off 1 : with memory of the frequency before power off	1	×	✓
Program operation mode	P94	Program operation mode option	0 : auto run cancelled 1 : auto run stops after a period 2 : auto run cycle operation 3 : auto run stops after a period (STOP intervals) 4 : auto run cycle operation (STOP intervals)	0	×	✓
	P95	Program operating direction setting	0~127	0	×	✓
	P96	First phase operating time setting	0~9999 s	0	×	✓
	P97	second phase operating time setting	0~9999 s	0	×	✓
	P98	third phase operating time setting	0~9999 s	0	×	✓
	P99	fourth phase operating time setting	0~9999 s	0	×	✓
	P100	fifth phase operating time setting	0~9999 s	0	×	✓

	P101	sixth phase operating time setting	0~9999 s	0	x	✓	
	P102	seventh phase operating time setting	0~9999 s	0	x	✓	
RS-485 communication mode option	P103	RS-485 communication address	1~254	1	x	✓	
	P104	Data transmission speed	0 : Data transmission speed , 4800 bps 1 : Data transmission speed , 9600 bps 2 : Data transmission speed , 19200 bps 3 : Data transmission speed , 38400 bps	1	x	✓	
	P105	Communication information format , 7 bit information format	0 : Modbus ASCII mode , info format<7.N,2> 1 : Modbus ASCII mode , info format<7.E,1> 2 : Modbus ASCII mode , info format<7.0,1> 3 : Modbus RTU mode , info format<8.N,2> 4 : Modbus RTU mode , info format<8.E,1> 5 : Modbus RTU mode , info format<8.0,1>	0	x	✓	
	P106	Communication response delay time	10 to 1000 (x 0.125 ms)	80	x	✓	
	P107	Transmission faults handling, braking methods	0 : warning and go on operation 1 : warning and deceleration braking 2 : warning and free braking 3 : no warning and go on operation	3	x	✓	
	P108	Transmission Over time detection	0.0 : no detection of transmission over time 0.1~120.0 s	0.0	x	✓	
	6	NO	Function description=	Setting range	Factory setting	R	S
		P109	Vibration prohibition factor	0.0~100.0%	20.0	✓	✓
Driver setting	P110	Cooling fan activation option	0 : fan runs with running of inverter, and closed 1min after inverter stops 1 : fan runs with running of inverter, and closed after inverter stops 2 : always running	2	x	✓	
	P111	Electronic heating relay option(OL1) Based on motor rated current	0 : no motion 1 : cooling fan with individual power (counting start point : 105%) 2 : motion with standard power(the lower the frequency , the lower the counting start point)	0	x	✓	
	P112	Electronic heating relay motion time	30~300 s	60	x	✓	
	P113	Over temperature protection setting	75.0~125.0 oC	95.0	x	✓	
	※ Only detect in operation:if temperature over (P113 - 5.0 oC) display "oH0"forecast , motor go on operation ; If temperature over P113 display "oH" , motor free braking ;						
	P114	Carrier frequency setting	1.0~15.0 KHz	5.0	x	✓	
	P115	AC Motor driver rated current display	3.0~600.0 A(read only)FLA	5.0	x	x	
	Motor parameters	P116	Motor rated voltage setting	180.0 ~ 460.0V	220.0	x	✓
P117		Motor rated current setting	30.0~120.0 % FLA (display as Amps)	100.0	x	✓	
P118		Rated frequency	20.00 ~150.00 Hz	50.00	60.00	x	✓
P119		Motor rated slip	0.00~10.00 Hz	3.00	x	✓	
P120		Motor power	0.10~400.00	1.00	x	✓	
P121		Motor poles	2~20	4	x	✓	
P122		Motor no load current setting	0.0~99.0 % * P117 (displayAmps)	40.0	x	✓	

	P123	Stator resistance	1.75~24.99	6.00	×	✓
	P124	Rotor resistance	1.75~24.99 %	6.00	×	✓
	P125	Stator self-inductance	80.0~750.0 %	200.0	×	✓
	P126	Mutual inductance	80.0~750.0 %	192.0	×	✓
Control mode	P127	Motor parameter measurement	0 : no measurement function 1 : no operating electric parameter detection 2 : with operating electric parameter detection	0	×	✓
	P128	Control mode	0 : V/F control 1 : vector control	0	×	✓
		※ Under water supply mode (P0=6) , vector control disabled , forced to V/F control .				
	P129	Auto voltage regulation AVR	0 : auto voltage regulation function activated 1 : auto voltage regulation function closed 2 : auto voltage regulation function closed when machine stops 3 : auto voltage regulation function closed in deceleration	0	×	✓
	P130	Auto energy-efficient operation function setting	0 : auto energy-efficient operation function disabled 1 : auto energy-efficient operation function activated	0	×	✓
VF control	P131	Auto torque compensation gain	0.0~10.0	0.0	✓	✓
	P132	V/F control slip offset gain	0~200%	0	✓	✓
	P133	V/F control output current limitation	20.0~180.0%	130.0	×	✓
Vector control	P134	Magnetic flux meter bandwidth	1.00~30.00 Hz	4.00	×	✓
	P135	Speed measuring device bandwidth	1.00~30.00 Hz	6.00	×	✓
	P136	Vector control slip offset gain	10~200%	100	✓	✓
	P137	Sensorless vector speed control P gain	1.0~200.0%	10.0	✓	✓
	P138	Sensorless vector speed control I gain	0.0~200.0%	20.0	✓	✓
	P139	Torque current limitation	0.0~200.0% , 『 limited to 2.5 times of motor rated current 』	130.0	✓	✓
	P140	Analogy torque current limitation	0:invalid ; 1: AV0(Knob in digital operator); 2: AVI(0~10V); 3: 4~20mA (ACI);	0	×	✓
		※ Under vector control , if P140 is not 0 , the torque current limitation is equal to analogy input AV(%) × P139				
	P141	Zero speed control option	0 : no output,pending 1 : controlled by magnetic field current	1	×	✓
	P142	Low speed magnetic field magnification	100.0~200.0%	145.0	✓	✓
	P143	Magnetic control starting frequency(pu)	10.0 ~ 100.0 %	35.0	×	✓

7	NO	Fuction description	Setting range	Factory setting	R	S
	P144	PID reference object source option	0~8	0	×	✓

		0 : no PID function 1 : knob in digital operator 2 : AVI (0~10V) 3 : 4~20mA (ACI) 4 : PID reference value setting (P155) 5 : HDI setting	6 : AI3 setting 7 : AI4 setting 8 : timing water supply setting			
P145	PID feedback object source option		0~7	0	×	✓
		0 : 0~10V (AVI) 1 : 4~20mA (ACI) 2 : HDI setting 3 : far-end communicate feedback setting (communicate adress 2001h)	4 : 0~100% (drive rated current) 5 : virtual feedback (2/S+1) 6 : -10~10V (AI3) 7 : 4~20mA (AI4)			
P146	PID output function		0 : positive(feedback value>command value , output frequency fall) 1 : negative(feedback value>command value , output frequency rise) ※ under water supply mode , forced to positive	0	×	✓
P147	Proportion (P) gain		0.00~300.0 %	100.0	✓	✓
P148	Integral (I) gain		0.00~300.00. %	40.00	✓	✓
P149	Differential (D) gain		0.00~300.00 %	2.00	✓	✓
P150	D input filtration time setting		0.04~2.50 s	0.20	✓	✓
P151	PID primary delay		0.00~2.50 s = 4 τ	0.00	✓	✓
P152	PID control , output control		0.00~100.00%	100.0	✓	✓
P153	Abnormal feedback signal detecting time		0.0 : no detection 0.1~3200 s (PID output>10.0 % , PID feedback<3.0 %)	60.0	×	✓
P154	PID feedback signal faults handling		0 : warning and deceleration braking 1 : warning and free braking	0	×	✓
P155	PID reference value setting address		0~P159	0	✓	✓
P156	PID deviation level		1.00~50.00%	10.00	×	✓
P157	PID deviation detecting time		0.1~300.0 s	5.0	×	✓
P158	Deviation limitation		0.00%~100.00%	0.0	×	✓
P159	PID 100% display value		0~9999	1000	✓	✓
P160	PID position of the display value radix point		0~3	1	✓	✓

	P161	HDI 0% corresponding frequency	0.000~32.000 KHz	0.000	×	✓	
	P162	HDI 100% corresponding frequency	0.000~32.000 KHz	1.440	×	✓	
	P163	HDI input digit filter	0~8000ms	100	✓	✓	
	P164	HDO monitor variable option	0 : setting frequency(0 to[output frequency upper limitation setting]) 1 : actual operate frequency 實際運轉頻率(0 to[output frequency upper limitation setting]) 2 : motor operate current (0 to 250% rated current) 3 : disply output voltage(0 to 125% rated voltage) 4 : disply PID feedback value 5 : AV0 knob in digital operator (%) 6 : AVI analogy signal 0~10V input (%) 7 : ACI analogy signal 4~20mA input (%) 8 : AI3 analogy signal -10~10V input (%) 9 : AI4 analogy signal 0~10V /4~20mA input (%)	1	✓	✓	
	P165	HDO 0% corresponding frequency	0.000~32.000 KHz	0.000			
	P166	HDO 100% corresponding frequency	0.000~32.000 KHz	1.440			
Others	P167	Accumulative machine available time (day)	0~9999(read only)	0	×	×	
	P168	Accumulative machine available time (min.)	0~1440(read only)	0	×	×	
	P169	Accumulative operation time (day)	0~9999(read only)	0	×	×	
	P170	Accumulative operation time (min.)	0~1440(read only)	0	×	×	
	P171	Inverter fuction setting		0~63	0	×	×
		B5(drive mode)	B4(VR operator)	B3(GFF protect)	B2(hardenite protect)	B1(expansion board function)	B0
4 power supply drive		no	close	close	open	VTmode	
(Normal mode		yes	open	open	close	CTmode	
e.g. : 4 power supply drive. no VR operator 、 open expansion board function 、 VT mode(110011b=32+16+2+1=51)							
	P172	Inverter model setting	100~299	101	×	×	
	P173	Key1	-1999~9999(1111)	0	×	✓	
	P174	Key2	-1999~9999(4545)	0	×	✓	

VT and CT mode :

1. Set bit0 of P171 value to 0 , CT mode(fixed torque) , the proportion between inverter rated and motor rated is 1:1.
2. Set bit0 of P171 value to 1 , VT mode(fluctuant torque) , motor rated can be one level higher than inveter rated.
3. Such as model 104(5 HP): under CT mode, the rated current is 17.0A; under VT mode, the rated current is 25.0A(7.5HP)

Expansion board function open :

1. Set bit1 of P171value to 0, no expansion board function, Pr.group parameter can't be setted, only can be used the same as general inverter.
2. Set bit1 of P171value to 1 , open up expansion board function , Pr.group parameter can be setted, can be used the same as general inverter or pump inverter.

RA	RB	RC	M0~M5	CM	MC1	MO1	DA1	ACI	AVI	HDI	HDO
RelayA1 digit output A、B、C contact			Digit input	Digit input Common contact	Open collector digit output1 common contact and output contact		0~10V Analogy output	4~20 mA Analogy input	0~10V Analogy input	Pulse wave input	Pulse wave output

SSP5800 Water Supply card manual

1 Model and specification

1.1 Model

The model NO of the water supply card is P5800GS. After installed with water supply expansion card, P5800 inverter can perform constant pressure water supply function; complete the setting and automatic logic switchover for variable frequency pump, power frequency pump, dormant pump and sewage pump in the system. At the same time, it can realize the function of multi-section water supply, dormant control, sewage control, regular switch of pump and detection of faulty variable frequency pump.

1.2 Outlook

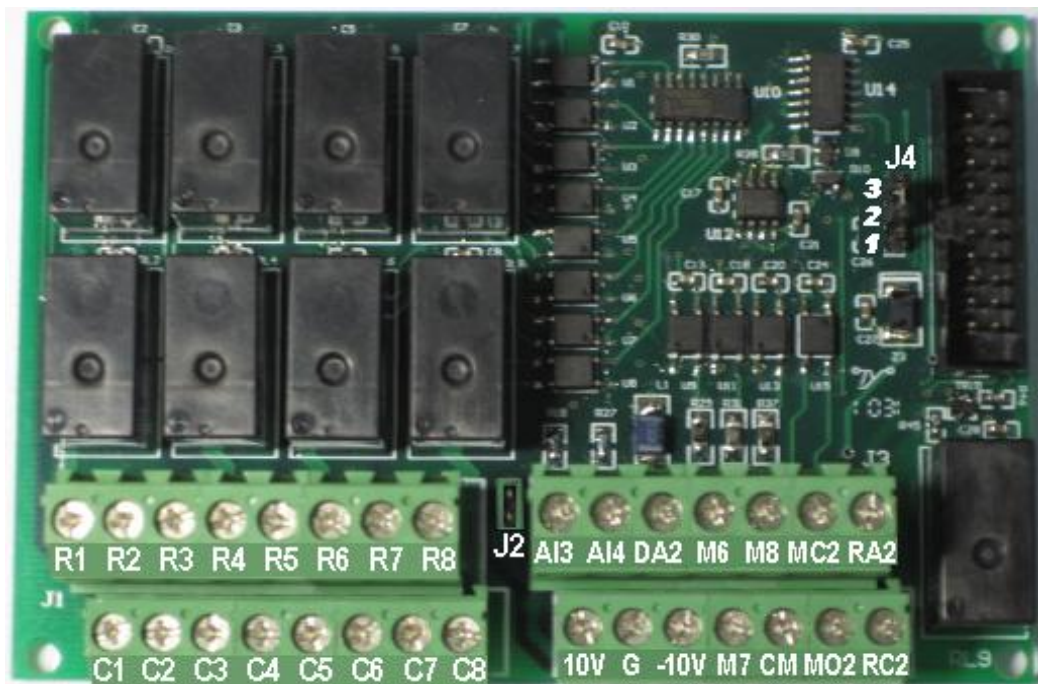
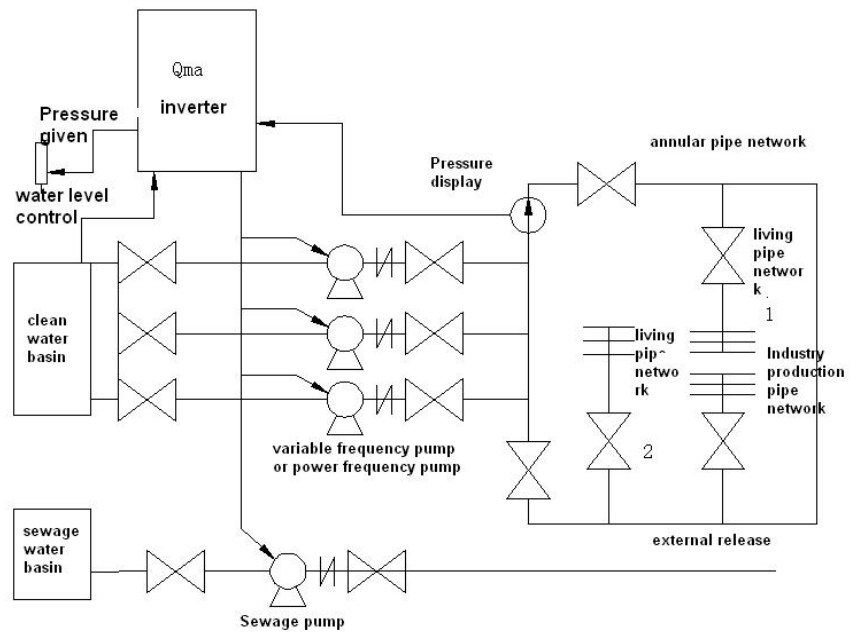

Fig1.1 outlook of the water supply card

2:Water supply card working diagram



3 Water supply card terminal illustration

Terminal NO	Description
M6~M8	ON-OFF signal input, optical coupling with PW and COM Input voltage range: 9-30V Input impedance: 30.3kf2
CM	M6~M8 common
MO2	Open collector output terminal
MC2	COM for open collector output terminal
AI3	Analog input, voltage range: -10V~10V Input impedance: 30K ohm
AI4	Analog input, voltage 0~10V/current 4~20ma can be switched by J2; input impedance: 30K ohm (voltage input) /500 ohm (current input)
DA2	Analog output: provide voltage output or current output, can be switched by J4

	Output range: voltage (0~10V) /current (4~20ma)
G	Analog grounding, analog input/output
10V	Analog power
-10V	Analog power
RA2	Relay2 fault pump output, output NO contact
RC2	RA2 COM

4 Jumper

NO	Illustration
J2	Pin1 and pin2 short connect: AI4:4~20ma Pin1 and pin2 open: AI4:0~10v
J4	Pin1 and pin2 short connect: DA2:4~20ma Pin1 and pin2 open: DA2:0~10v

5. Terminal sequence

5.1 Function terminal sequence

AI3	AI4	DA2	M6	M8	MC2	RA2
10V	G	-10V	M7	CM	MO2	RC2

5.2 Relay output terminal sequence

R1	R2	R3	R4	R5	R6	R7	R8
C1	C2	C3	C4	C5	C6	C7	C8

5.3 RS485 plug definition

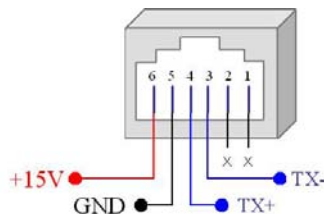

6. Water supply expansion card function illustrations

Note: Only when the inverter is equipped with water supply expansion card, can the users browse and amend the following parameters.

Pr.00	A pump selection		Default	0
Pr.01	B pump selection		Default	0
Pr.02	C pump selection		Default	0
Pr.03	D pump selection		Default	0
	Setting range	0	Pump invalid	
		1	Dedicated dormant pump	
		2	Dedicated sewage pump	
		3	Power frequency pump	
		4	Variable frequency pump	

Pr.04	E pump selection		Default	0
Pr.05	F pump selection		Default	0
Pr.06	G pump selection		Default	0
	Setting range	0	Pump invalid	
		1	Dedicated dormant pump	
		2	Dedicated sewage pump	
		3	Power frequency pump	

0: Pump invalid

The corresponding pump is not installed or does not work.

1: Variable frequency pump

The corresponding pump is started by inverter. When it cannot be switched, the pump can adjust the output automatically as variable adjust pump to make sure the pressure to be constant. When fulfilling the switch requirement, the pump will switch to run at power frequency or stop running.

2: Power frequency pump

The pump only run at power frequency, when the capacity of power network is big enough and the power of pump is less than 15kW, the pumps will be started with total voltage directly. If the power of pump is greater than 18.5KW. it is suggested to start with buck start-up mode. Such as Star-Delta step-down start. Auto coupling step-down start and soft start, so as to reduce impact on pipe network and power network system.

3: Dedicated dormant pump

The corresponding pump will be work as the system dormancy pump. When dormancy conditions are fulfilled, the system will be on the dormancy running state, and it automatically enter or awaken the dormancy state according to the setting dormancy pressure and deviance tolerance.

4: Dedicated dredge pump

It is a power frequency pump, when water level of Sewage-pool control function is enabled, and water level sensors are installed correctly. System will start and stop of sewage pump according to the detected water-level signals.

(Note: When parameter P55~P88 and Pr.65~Pr.67 set to 51 and 52, the dedicated sewage pump will be valid.)

Note1: The dormancy pump will only be valid under the mode of dormancy water supply.

Note2: Sewage pump and dormancy pump can only work under power frequency mode.

Pr.07	A pump rated current	Default	100
Pr.08	B pump rated current	Default	100
Pr.09	C pump rated current	Default	100
Pr.10	D pump rated current	Default	100
	Setting range	30.0%~120%FLA (display as Amaps)	

Users please set the above parameter according to each motor's nameplate; the setting of these parameter will influence the inverter's overload protection over motor.

Pr.11	R1 output function selection	Default	0
Pr.12	R2 output function selection	Default	0
Pr.13	R3 output function selection	Default	0
Pr.14	R4 output function selection	Default	0
Pr.15	R5 output function selection	Default	0
Pr.16	R6 output function selection	Default	0
Pr.17	R7 output function selection	Default	0
Pr.18	R8 output function selection	Default	0
	Setting range	0	No function
		1	A pump variable frequency control
		2	A pump power frequency control
		3	B variable frequency control
		4	B pump power frequency control
		5	C variable frequency control
		6	C pump power frequency control
		7	D variable frequency control
		8	D pump power frequency control
		9	E pump power frequency control
		10	F pump power frequency control
		11	G pump power frequency control

The above parameters are to set the relay output function of the water supply card, details see below:

Setting value	Function	Remark
0	No function	Set each pump's control signal. Variable frequency pump need two control signals(variable frequency control and power frequency control).Power frequency pump, sewage pump and dormancy pump only need one signal, it must be set as power frequency control signal。
1	A pump variable frequency control	
2	A pump power frequency control	
3	B variable frequency control	
4	B pump power frequency control	
5	C variable frequency control	
6	C pump power frequency control	
7	D variable frequency control	
8	D pump power frequency control	
9	E pump power frequency control	
10	F pump power frequency control	
11	G pump power frequency control	

Pr.19	Adding pump tolerance	Default	10.00
	Setting range	0.00~30.00%	
Pr.20	Running frequency of adding pump	Default	50.00
	Setting range	0.00~P26 HZ	
Pr.21	Delay time of adding pump	Default	5
	Setting range	0~3600s	
Pr.22	Switching frequency of adding pump	Default	50.00
	Setting range	0.00~P26 HZ	

The four parameters set the conditions of adding pump.

1:When frequency of variable-frequency pump reach the frequency of Pr.20, at the same time, pressure feedback value<pressure set value-pressure tolerance, and it lasts for delay time (determined by Pr.21), then the system adds pump.

2: 100% of pressure tolerance is corresponding with 100% relative feedback pressure.

3: Pr.20 is a threshold frequency to add pump. When the pressure conditions are not satisfied. pump-added logic is started, which is as following:

Add power frequency pump: Start the pumps using programmable relay, at the same time the current variable frequency pump decelerate to the frequency of misusing pump according to the set deceleration time determined by Pr.21 and then go on running with PID control. It can stabilize fluctuate of system

pressure and decrease pressure jump when add pump.

4: Pr.22 switching frequency of variable frequency pumps.

In the switch process, there is delay time from disconnecting variable frequency contactor to closing power frequency contactor, so variable frequency pump will accelerate to a higher frequency (which is the switch frequency) before switching in order to make up the depreciation of pipe network pressure in the delay time.

The switch process is as follow: Variable-frequency pump accelerates to the switch frequency. stops output and disconnects the contactor. finally closes power frequency contactor.

Pr.23	DEC time of variable frequency pump when adding power frequency pump	Default	10.00
	Setting range	0.01~600s	

The conditions of adding pump are satisfied, if the added pump is power frequency pump, the variable-frequency pump should decelerate to the frequency of misusing pump according with the setting deceleration time, and goes on carrying out with PID control. In the process, the deceleration time is set by Pr.20.。

Pr.24	Reducing pump tolerance	Default	10.00
	Setting range	0.00~30.00%	
Pr.25	Running frequency when reducing pump	Default	5.00
	Setting range	P25~Pr.20HZ	
Pr.26	Delay time of reducing pump.	Default	5
	Setting range	0~3600s	

The three parameters above set the conditions of reducing pump.

1. When frequency of variable frequency pump reaches the frequency (determined by Pr.25), at the same time, the feedback pressure > setting pressure + pressure tolerance and it lasts for delay time(determined by Pr.26), the system starts to reduce pump.
2. 100% of the pressure tolerance is corresponding to 100% of the feedback pressure.
3. Pr.25: running frequency of reducing pump: When there are still power frequency pump running, what is more the current variable frequency pump frequency reaches the frequency of reducing pump and lasts for delay time(determined by Pr.26), the system starts to reduce pump. When adding pump, variable frequency pump need to reach this frequency to avoid pipe network pressure depreciation.

Pr.27	Acc time of converting pump	Default	10.00
-------	-----------------------------	---------	-------

	during reducing pump		
	Setting range	0.01~600s	

When the conditions of reducing pump satisfied, the system will cut off the power frequency pump. The variable frequency pump should accelerate to the frequency of adding pump according to the setting accelerate time and go on running with PID control. This function can make up the pipe network pressure depreciation caused by reducing power frequency pump.

Pr.28	Switch on time of the contactor	Default	0.5S
Pr.29	Switch off time of the contactor	Default	0.5S
	Setting range	0.2~10.0s	

It's considered that there are mechanical delay times when contactor closes or opens, even more there are remanence when variable frequency pump switch to run at grid frequency which may make the action failure. The parameters above are used to solve these problems.

1: Before inverter enables the next available frequency pump, it will send contactor closing command, there is time difference between commands has been sent and the inverter starts to output by reason of mechanical delay, that's contactor closing time.

2: The contactor opening time is the time which is different from the inverter outputs coast to stop command to inverter outputs power frequency contactor closing command. It normally used for which the power of pump is greater than 45kW and the variable-frequency pump needs to be switched to run at grid frequency, It can minimize switching current and improve the success percentage of switching.

Pr.30	Round-robin cycle of power frequency pump	Default	0.0
	Setting range	0~6553.5hr	

The parameter set the timing circulation period of power frequency pump.

0: Invalid.

Pumps switching logic is First-In-First-Out.

Not 0: Valid.

The setting value is circulation period. It is suggested that the function should be selected when the capacity of each power frequency pump are almost the same (except sewage pump and dormancy pump).

If there are two or more power frequency pumps, so all pumps (except sewage pump and dormancy pump) will join the rotation, no rotation if there is only one power frequency pump.

Pr.31	Round-robin cycle of variable frequency pump	Default	0.0
	Setting range	0~6553.5hr	

The setting is similar to power frequency pump, please refer to Pr.30

Pr.32	Manual soft-starting frequency switch	Default	50.00
	Setting range	0.00~P26 HZ	

When use manual soft start, the parameter sets the running frequency of inverter before witching to power frequency pump.

Pr.33	Current moment	Default	
	Setting range	00.00~23.59	

When enter this parameter, press ENT to set the time. This parameter illustration as below:

10. 30 refers to 10:30.

The time is the base standard for setting multi-pressure time. the parameter will update as real-time.

If enter this parameter without modifying, it can be used as time reference updating every minutes.

If there is input error of wrong format during modifying, the modifying time cannot be confirmed.

Pr.34	T1 starting moment	Default	00.00
Pr.35	T2 starting moment	Default	00.00
Pr.36	T3 starting moment	Default	00.00
Pr.37	T4 starting moment	Default	00.00
Pr.38	T5 starting moment	Default	00.00
Pr.39	T6 starting moment	Default	00.00
Pr.40	T7 starting moment	Default	00.00
Pr.41	T8 starting moment	Default	00.00
	Setting range	00.00~23.59 (T1 < T2 < ----- < T8)	

Pr.42	T1 segment pressure P1	Default	0
Pr.43	T2 segment pressure P2	Default	0
Pr.44	T3 segment pressure P3	Default	0
Pr.45	T4 segment pressure P4	Default	0
Pr.46	T5 segment pressure P5	Default	0
Pr.47	T6 segment pressure P6	Default	0
Pr.48	T7 segment pressure P7	Default	0
Pr.49	T8 segment pressure P8	Default	0
	Setting range	0~P159	

These parameters are for setting the pressure segment and corresponding pressure.

- 1 .Principle of setting time: T1<_T2<_T3<_T4<_T5<_T6<_T7<_T8
2. Segment T1 is the time from threshold T1 to threshold T2, segment T2 is the time from threshold T2 to threshold T3, and so forth, segment T8 is the time from threshold T8 to threshold T1.
3. If threshold of one segment is same as ultimate of previous segment, the segment is invalid, and they are merged as one segment.
4. If the segments are equal. only one segment is effective everdvav.

Pr.50	Dormant time selection	Default
	Setting range	0~511

This parameter is to set the dormant time.

0: Dormant disabled。 No dormant running。

1~255: dormant pressure segment selection, choose one from 8 time segments as dormant pressure segment. Multi-segment pressure dormant is available(set according to binary).

256: Dormant enable in non regular water supply segment

Setting method as below:

Bit7	Bit6	Bit5	Bit4	Bit3	Bit2	Bit1	Bit0
T8 time segmen t	T7 time segme nt	T6 time segme nt	T5 time segme nt	T4time segme nt	T3time segme nt	T2time segme nt	T1time segme nt

Pr.51	Dormant pressure tolerance	Default	10.00
	Setting range	0.00~30.00%	
Pr.52	Dormant delay time of adding/reducing pump	Default	5.00
	Setting range	P25~Pr.20HZ	
Pr.53	Dormant awaken enabled	Default	0
	Setting range	0	Invalid
		1	Valid

This parameter is to start/stop the pump and awaken dormant during inverter dormant time.

1: If dormant pump is running, what is more, feedback pressure>dormant setting pressure + Pr.51, and it lasts for delay time(determined by Pr.52), the dormant pump will stop.

2: If dormant pump is running, feedback pressure<setting dormant pressure -Pr.51, and it lasts for delay time(determined by Pr.52), the variable frequency pump will start. If dormant awaken is invalid (Pr.53=0) , the variable frequency pump will not start, only dormant pump keep running.

- 3: If variable frequency pump awakened, what is more, feedback pressure > dormant setting pressure + Pr.51, and it lasts for delay time(determined by Pr.52), variable frequency pump will stop first.
4. If dormant pump stop at stop(variable frequency pump at stop), feedback pressure < dormant setting fressure-Pr.51, and it lasts for delay time(determined by Pr.52), dormant pump will restart.
5. Dormant pipe network pressure working status as following:

Pipe network pressure

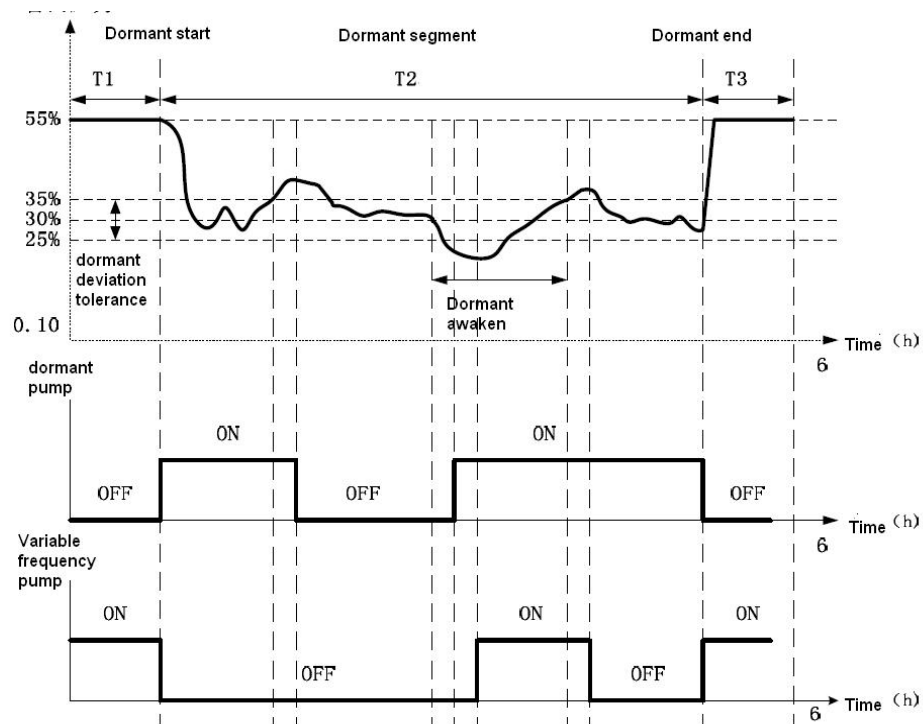

Fig 7.2 Dormant pump and variable frequency pump working figure in dormant status

Remark:

T1 pressure given: Pr.42=55%

Dormant segment selection: Pr.50=2

Dormant pressure given: Pr.43=30%

Dormant pressure tolerance: Pr.51=5%

Dormant awoken enable: Pr.53=1

Pr.54	Over voltage protection value	Default	90.00
	Setting range	0.00~100.00%	
Pr.55	Over voltage delay time.	Default	5.00
	Setting range	0~3600s	

Pr.56	Under voltage protection value	Default	10.00
	Setting range	0.00~100.00%	
Pr.57	Under voltage delay time	Default	5.00
	Setting range	0~3600s	

Above parameters are for setting of over/under voltage pressure and judging time.

When pipe network pressure reach the max pressure (determined by pr.54), and it lasts for delay time(determined by Pr.55), system will warning over voltage. After the warning, when voltage lower than over voltage protection value, and lasts for delay time(determined by Pr.55), the warning can be removed. Under voltage judgment is similar to over voltage.

Pr.58	Receiving basin water level signal selection	Default	0
	Setting range	0	No input
		1	by switching value input terminal
		2	AVI
		3	ACI
		4	AI3
	Setting range	5	AI4
		6	HDI
		7	Remote communication

The parameter is to set whether to perform the water level signal control of the receiving basin.

0: No input: Do not perform water level signal control of the water receiving basin.

1:Input by digital input terminal. Receiving basin's water level signal input by digital input terminal, thus to control the water level of the receiving basin. SO P55, P56, P57, P58, Pr.65, Pr.66, Pr. 67 multi function terminal set as 48 ~ 50.

2. Input by analog input terminal AVI, level limit is confirmed by Pr.59~ Pr.61.

3. Input by analog input terminal ACI, level limit is confirmed by Pr.59~ Pr.61.

4. Input by analog input terminal AI3, level limit is confirmed by Pr.59~ Pr.61.

5. Input by analog input terminal AI4, level limit is confirmed by Pr.59~ Pr.61.

6. Input by HDI high speed pulse, level limit is confirmed by Pr.59~ Pr.61.

7. Input by remote communication, level limit is confirmed by Pr.59~ Pr.61

Water level control mode:

1:When pool level changes from high to low, and the level is higher than lower limit level, system runs with normal setting pressure mode. When the level is lower than lower limit level and higher than water shortage level, system runs with abnormal spare pressure mode (determined by P8.32); when the level is lower than water shortage level, system stop running.

2. When pool level changes from low level to high level, system do not run when the level is lower than the lower limit level, when the level is higher than lower limit level and lower than the upper limit level, system run with spare pressure mode (determined by Pr.62);
When the level is higher than upper limit level; system returns to run with normal pressure.

Pr.59	Receiving basin water level upper limit	Default	50%
	Setting range	0~100%	
Pr.60	Receiving basin water level lower limit	Default	30%
	Setting range	0~Pr.59	
Pr.61	Water shortage level of receiving basin	Default	10%
	Setting range	0~Pr.60	

Above parameter are to set analog water level
100% of this pressure is corresponding to the 100% of the water basin feedback pressure.

Pr.62	Abnormal back up pressure	Default	0.0%
	Setting range	0~P159	

According to the above, when abnormal back up pressure start, to avoid the fast dropping of water basin level caused by inputting pipe network speed<outputting water pipe network speed, thus to prevent pump drawing in air, back up pressure running is required.

Pr.63	Fault record	Default	
	Setting range	0~127 (according to each pump)	

Under constant pressure water supply mode, if one variable frequency pump occur fault, inverter will automatically record the fault corresponding to each pump (corresponding bit=1). When fault process Pr.64 =1, the corresponding pump type will be invalid, and exit the system running automatically, at the same time, it will also exit switching logic.

Bit7	Bit6	Bit5	Bit4	Bit3	Bit2	Bit1	Bit0
Reserved	Pump7	Pump 6	Pump 5	Pump 4	Pump 3	Pump 2	Pump 1

For example: if Pr.63=35D=00100011B, means pump 1 , pump 2 and pump6 have fault.

Pr.64	Fault process	Default	0
-------	---------------	---------	---

	Setting range	0	System all stop
		1	Inverter switch to next variable frequency pump, if there is no variable frequency pump, it switches to power frequency pump.

The above parameters are for the fault process.

0: system all stop: when variable frequency pump become fault, system all stop. Pump clear setting should be performed manually by set the terminal as motor invalid.

1: Inverter switch to next variable frequency pump, if there is no variable frequency pump, it switches to power frequency pump.

Q5800 input terminals additional functions.

P55	M2 terminal function selection	Default	0
P56	M3 terminal function selection	Default	0
P57	M4 terminal function selection	Default	0
P58	M5 terminal function selection	Default	0
Pr.65	M6 terminal function selection	Default	0
Pr.66	M7 terminal function selection	Default	0
Pr.67	M8 terminal function selection	Default	0
	Setting range	32	Manual round-robin cycle command
		33	Manual soft-start debugging
		34	Motor A Manual soft-start
		35	Motor B Manual soft-start
		36	Motor C Manual soft-start
		37	Motor D Manual soft-start
		38	Reserved
		39	Reserved
		40	Reserved
		41	Motor A invalid
		42	Motor B invalid
	Setting range	43	Motor C invalid
		44	Motor D invalid
		45	Motor E invalid
		46	Motor F invalid
		47	Motor G invalid
		48	Receiving basin water level upper limit
		49	Receiving basin water level lower limit
		50	Receiving basin water shortage level
		51	Sewage basin water level upper limit
		52	Sewage basin water level lower limit

32: As per maintenance needs of equipment, manual inspection can be performed by this function. Set this terminal valid, inverter will enter round inspection status, it is similar to variable frequency pump round-robin.

33: To ensure safety debugging, when each motor perform manual soft-start,

this terminal must be set to 1 (short connect to CM).

33~37: It is used to soft start corresponding variable frequency motor by manual, which can be applied together with manual soft-start enable terminals. When manual soft-start enable terminal and corresponding motor's manual soft-start command valid at the same time, this motor will soft –start by inverter. When frequency reaches the switch frequency of Pr.20, it will switch to power frequency running. If at one time, there are several motors with valid manual soft-start commands, inverter will perform soft-start and frequency switch according to the terminal closing sequence of each motor.

41~47: It is used to exit motors that with fault or needs inspection by manual. When this command is valid, the corresponding motor will not be in the system's switch logic. This function will improve the system's switching efficiency.

48~50: When pool level changes from high to low, and the level is higher than lower limit level, system runs with normal setting pressure mode. When the level is lower than lower limit level and higher than water shortage level, system runs with abnormal spare pressure mode (determined by P8.32); when the level is lower than water shortage level, system stop running.

When pool level changes from low level to high level, system do not run when the level is lower than the lower limit level, when the level is higher than lower limit level and lower than the upper limit level, system run with spare pressure mode (determined by Pr.62);

When the level is higher than upper limit level; system returns to run with normal pressure.

51~52: Sewage basin water level signal input: when sewage water level higher than water level upper limit, sewage pump start running. When sewage water level lower than water level lower limit, sewage pump stop running.

Pr.68	Multi function output terminal MO2 (same as P64,P65)	Default	29
Pr.69	Multi function output terminal RA2 (same as P64,P65)	Default	30
	Setting range	25	Over voltage indication
		26	Under voltage indication
		27	Dormant running indication.
		28	Back up pressure running indication
		29	Water shortage indication
		30	Fault pump indication

25: When pipe network pressure reaches or higher than Pr.56 under voltage protection value and lasts for delay time(determined by Pr55), this signal is valid.

26: When pipe network pressure reaches or lower than Pr.56 under voltage protection value and lasts for delay time(determined by Pr57), this signal is valid.

27: When system enters dormant running status, dormant running indication signal is valid.

28: When system satisfies the conditions of back up pressure running(please refer to water level signal input function), the system will run under back up pressure, this signal is valid.

29: When receiving basin water level lower than water shortage level, this signal is valid.

30: When PR.63 \neq 0(means there is fault pump), this signal is valid.

Note: please refer to Q5800 manual during operation.

Pr.70	AI3:-10V input		Default	-100
	Setting range	-200.0%~200.0%		
Pr.71	AI3: 10V input		Default	100
	Setting range	-200.0%~200.0%		
Pr.72	AI3 input digital filtering		Default	50
	Setting range	0~9999ms		
Pr.73	AI4 type		Default	0
	Setting range	0	0~10V	
		1	4~20ma	
Pr.74	AI4:4ma input		Default	0
	Setting range	-200.0%~200.0%		
Pr.75	AI4: 20ma input		Default	100
	Setting range	-200.0%~200.0%		
Pr.76	AI4 input digital filtering		Default	50
	Setting range	0~9999ms		
Pr.77	DA2 type		Default	0
	Setting range	0	0~10V	
		1	4~20ma	
Pr.78	DA2 signal setting		Default	0
	Setting range	0	Analog frequency meter (0~ output frequency upper limit)	
		1	Analog ammeter (0~250% rated current)	
		2	Feedback signal output (0~100%)	
		3	Output power (0~100%)	
		4	Internal variables/P84	
Pr.79	DA2 gain setting		Default	100
	Setting range	0~200.0%		

7. Water supply card control function list

Code	Parameter illustration	Setting range	Default value	Ref
Pr.00	A pump type selection	0~4	0	
Pr.01	B pump type selection	0~4	0	
Pr.02	C pump type selection	0~4	0	
Pr.03	D pump type selection	0~4	0	
Pr.04	E pump type selection	0~3	0	
Pr.05	F pump type selection	0~3	0	
Pr.06	G pump type selection	0~3	0	
Pr.07	A pump rated current	30.0~120.0%	100	
Pr.08	B pump rated current	30.0~120.0%	100	
Pr.09	C pump rated current	30.0~120.0%	100	
Pr.10	D pump rated current	30.0~120.0%	100	
Pr.11	R1 output function selection	0~11	0	
Pr.12	R2 output function selection	0~11	0	
Pr.13	R3 output function selection	0~11	0	
Pr.14	R4 output function selection	0~11	0	
Pr.15	R5 output function selection	0~11	0	
Pr.16	R6 output function selection	0~11	0	
Pr.17	R7 output function selection	0~11	0	
Pr.18	R8 output function selection	0~11	0	
Pr.19	Adding pump tolerance	0. 0~30.0%	10	
Pr.20	Running frequency of adding power frequency pump	0. 00~P26	50	
Pr.21	Delay time of adding pump	0~3600s	5	
Pr.22	Switch frequency of variable frequency pump	0. 00~P26	50	
Pr.23	Deceleration time of converting pump during adding power pump	0. 01~600s	10	
Pr.24	Reducing pump tolerance	0. 0~30.0%	10%	
Pr.25	Running frequency of reducing pump	P25~Pr.20	5	
Pr.26	Delay time of reducing pump	0~3600s	5	
Pr.27	Acc time of converting pump during reducing pump	0.01~600s	10	
Pr.28	Switch on time of the contactor	0.2~10.0s	0.5	
Pr.29	Switch off time of the contactor	0.2~10.0s	0.5	
Pr.30	Round-robin cycle of power frequency pump	0~6553.5hr	0. 0	
Pr.31	Round-robin cycle of converting pump	0~6553.5hr	0. 0	
Pr.32	Switching frequency of manual	0. 00~P26	50	

soft-starting				
Code	Parameter illustration	Setting range	Default value	Ref
Pr.33	Current moment	0~1439	00.00	
Pr.34	T1 starting moment	0~1439	00.00	
Pr.35	T2 starting moment	0~1439	00.00	
Pr.36	T3 starting moment	0~1439	00.00	
Pr.37	T4 starting moment	0~1439	00.00	
Pr.38	T5 starting moment	0~1439	00.00	
Pr.39	T6 starting moment	0~1439	00.00	
Pr.40	T7 starting moment	0~1439	00.00	
Pr.41	T8 starting moment	0~1439	00.00	
Pr.42	T1 segment pressure P1	0~P159	0	
Pr.43	T2 segment pressure P2	0~P159	0	
Pr.44	T3 segment pressure P3	0~P159	0	
Pr.45	T4 segment pressure P4	0~P159	0	
Pr.46	T5 segment pressure P5	0~P159	0	
Pr.47	T6 segment pressure P6	0~P159	0	
Pr.48	T7 segment pressure P7	0~P159	0	
Pr.49	T8 segment pressure P8	0~P159	0	
Pr.50	Dormant time selection	0~255	0	
Pr.51	Dormant pressure tolerance	0. 00~30.00%	10.00%	
Pr.52	Delay time of adding/reducing pump when dormant	0~3600s	5	
Pr.53	Dormant awaken enable	0~1	0	
Pr.54	Over voltage protection value	0~100%	90%	
Pr.55	Over voltage delay time	0~3600s	500	
Pr.56	Under voltage protection value	0~100%	10%	
Pr.57	Under voltage delay time	0~3600s	500	
Pr.58	Receiving basin water level signal selection	0~7	00.00	
Pr.59	Upper limit water level of receiving basin	0~100%	50%	
Pr.60	Lower limit water level of receiving basin	0~Pr.60	30%	
Pr.61	Water shortage level of receiving basin	0~Pr.61	10%	
Pr.62	Back up pressure	0~P159	0	
Pr.63	Faulty record	0~15	0	
Pr.64	Fault processing	0~1	0	
Pr.65	Multi-function input selection M6	Same as P55	0	
Pr.66	Multi-function input selection M7	Same as P55	0	
Pr.67	Multi-function input selection M8	Same as P55	0	
Pr.68	Multi-function output terminal MO2	Same as P64	29	

Pr.69	Multi-function output terminal RA2	Same as P64	30	
Pr.70	AI3: -10V input	-200.0%~ 200.0%	-100.0%	
Pr.71	AI3: 10V input	-200.0%~ 200.0%	100.0%	
Pr.72	AI3 input filter	0~9999ms	50	
Pr.73	AI4 type	0~1	0	
Pr.74	AI3: 4ma/0v input	-200.0%~ 200.0%	0	
Pr.75	AI3: 20ma/10v input	-200.0%~ 200.0%	100%	
Pr.76	AI3 input filter	0~9999ms	50	
Pr.77	DA2 type	0~1	0	
Pr.78	DA2 signal setting	0~4	0	
Pr.79	DA2 gain setting	0.0~200.0%	100. 0%	