



SSInverter Co.,Ltd

SSI3300 Series Operating Manual



SSInverter Co.,Ltd.

CONTENTS

Preface	3
Chapter1 Safety and Precautions	6
1.1 Safety Precautions.....	6
1.2 Attention Items.....	8
Chapter 2 Product Information	11
2.1 Naming Rules.....	11
2.2 Nameplate	11
2.3 SSI3300 Inverter Series	12
2.4 Technical Specification	13
2.5 Physical Appearance and Dimensions of Mounting Hole.....	16
2.6 Optional Parts.....	21
2.7 Routine Repair and Maintenance of Inverter	22
2.8 Warranty of Inverter	23
2.9 Guide to Select Brake Components	24
Chapter 3 Mechanical and Electrical Installation	27
3.1 Mechanical Installation	27
3.2Electrical Installation	31
Chapter 4 Operation and Display	43
4.1 Operation and Display Interface Introduction.....	43
4.2 Organization Way of the Inverter Function Code.....	45
4.3 Instruction of Function Code Viewing and Modification Methods.....	46
4.4 Function Code Menu Mode and Switch Description	47
4.5 Preparation before Running	49
4.6 Start-stop Control of the Inverter	52
4.7 Running Frequency Control of the Inverter	57
4.8 Motor Characteristic Parameter Setting and Automotive Tuning	62
4.9 Usage of Inverter DI Ports	64
4.10 Usage of Inverter DO Ports.....	65
4.11 AI Input Signal Character and Pretreatment.....	65
4.12 Usage of Inverter AO port.....	66
4.13 Usage of Inverter Serial Communication.....	67
4.14 Password Setting.....	67
Chapter 5 Parameter Description	68
5.1 Group F0 Basic Function	68
5.2 Group F1 Start-stop Control Function Group	76
5.3 Group F2 V/F Control Parameter.....	79

5.4 Group F3 Vector Control Parameter.....	82
5.5 Group F4 Motor Parameter	85
5.6 Group F5 Input Terminal.....	86
5.7 Group F6 Output Terminal.....	95
5.8 Group F7 Auxiliary Function and Panel Display	100
5.9 Group F8 Communication Parameter	109
5.10 Group F9 Fault and Protection.....	110
5.11 Group FA PID Function	116
5.12 Group Fb Swing Frequency and Fixed Length Count.....	121
5.13 Group FC Multi-segment Command and Simple PLC Function	123
5.14 Group Fd Torque Control Parameter.....	127
5.15 Group FE AI Multi-point Curve Setting	129
5.16 Group FF Default Parameter.....	130
5.17 Group H0 Second Motor Parameter Setting.....	130
5.18 Group H1 Second Motor Parameter.....	131
5.19 Group H2 Second Motor VF Curve Setting.....	132
5.20 Group H3 Second Motor Vector Control Parameter	132
5.21 Group L0 System Parameter	133
5.22 Group L1 User Function Code Customization.....	133
5.23 Group L2 Optimizing Control Parameter.....	135
5.24 Group L3 AIAO Correction Parameter	136
5.25 Group L4 Master-slave Control Parameter	137
5.26 Group L5 Mechanical Braking Function Parameter	138
5.27 Group L6 Wake-up Function Parameter.....	140
5.28 Group U0 Fault Record Parameter.....	142
5.29 Group U1 State Monitor Parameter	142
Chapter6 EMC(Electromagnetic Compatibility)	145
6.1 Definition.....	145
6.2 Standard Description.....	145
6.3 EMC Guide	145
Chapter 7 Trouble Shooting	148
7.1 Fault Warnings and Solutions	148
7.2 Common Faults and Treating Methods.....	153
Appendix A SSI3300 Series Modbus Communication Protocol.....	155
Appendix B Function Code Table.....	165

Preface

Thank you for purchasing SSI3300 series of Control Inverter.

SSI3300 series inverter is a technology upgraded product launched through market research, which have been widely applied in the market. The new series are excellent in performance, reliability and stability, easy to operate. It will bring you better user experience.

We have introduced the function characteristics and usage of SSI3300 series of inverter in this instruction manual, including type choosing, parameter setting, and operation debugging and maintenance inspection etc, please read the manual carefully before the usage. The device supplier will enclose this manual with the device when sending it to the user for their reference.

Cautions

- **In order to display the details of the product, some products which illustrated in the diagrams of the manual are without outer cover or safety shield. Please do make the machine completed with cover or shield in the actual operation and run it according to the details of the manual.**
- **The diagrams in the manual are just for the purpose to explanation, it may be different from the product you purchased.**
- **We are devoted to continuous improvement of the products, so followed with the function upgrading. You will not be specially informed if the reference data is updated.**
- **Any problems please contact our regional agents or call our customer service directly.**

☆ Unpacking inspection:

Please confirm below items carefully when unpacking the box:

- 1、 If the nameplate information and the rated value are right as your order request. The product certification, user manual and warranty card are enclosed with the machine packed in the box.
- 2、 If the product is damaged during the transportation. Please contact our company or the supplier immediately if there is any missing parts or damage.

☆ First-time use:

For the operator without using experience should read this manual carefully .For any doubt about certain functions and performances, please consult the technical support representatives of our company for help. It's beneficial to use the product in proper way.



SSI3300 series of inverters meet the international standards in below, and the products have passed the CE standards.

IEC/EN 61800-5-1: 2007 Safety Regulation requirement of speed adjustable Electric Drive System

IEC/EN61800-3: Speed adjustable Electric Drive System;

Part three: EMC Standard and the Specific Testing Method of the Products. (According to 6.3.2 and 6.3.6, under the circumstance of right installation and usage, meet the standard of IEC/EN 61800-3)

- Don't install capacitors or surge suppressors on the output side of the inverter. This will lead the breakdown of the inverter or the damage of the capacitor and surge suppressor.
- The harmonic included in the input/output circuit (main circuit) may interfere with the communication devices of the inverter accessories. So anti-interference filter need to be installed to decrease the interference to the minimum.
- You can refer to the peripherals choose part to get more details of the peripheral devices.

☆ **Connecting to the peripherals:**

Please use the right power supply within allowed specification.

Pay attention to use short-circuiter for the big impact current when start the power.

Don't use magnetic contactors to start or stop the inverter, or it will shorten the service life of the inverter.

Suppress the high harmonic to improve the power factor.

Reduce the electromagnetic interference of the input side.

The motor and the inverter must be grounded well to avoid electric shock

Reduce the electromagnetic interference of the output side.

**Safety
GND**

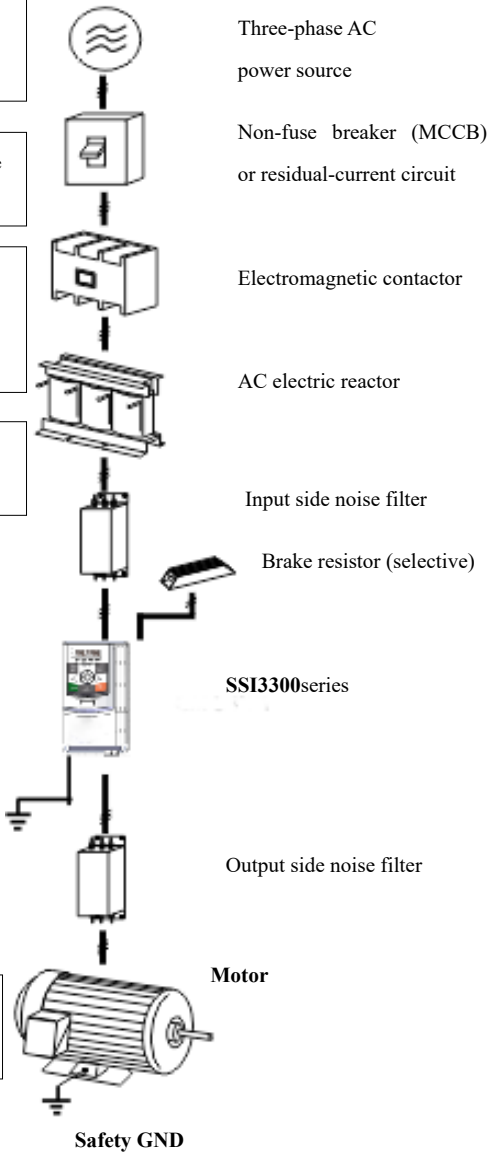

Fig.1 illustration of connecting to the peripheral machines

Chapter1 Safety and Precautions

Safety definition:

In this manual, safety precautions are divided into two types below:





Danger arising due to improper operations may cause severe hurt or even death.



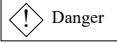

Danger arising due to improper operations may cause moderate hurt or light hurt or equipment damage.

Please read the manual carefully before install, debug or maintain the system; following the safety rules that indicated in the detail. If any injury caused by rule-breaking operations, our company has no responsibility for it.

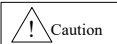
1.1 Safety Precautions

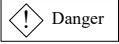
Status	Safety class	Items
Before installing	 Danger	Do not install it if the control system is moistened, parts missing or components damaged. Do not install if the real objects are different from the packing list.
	 Caution	It should be handled with care during moving, otherwise there is risk of damage the device. Don't use the damaged drive or inverter with missing parts or there is danger of hurt. Don't use your hand to touch the components of the control system or there is risk of static damage.
During installing	 Danger	Install the inverter on incombustible surface like metal; stay away from combustibile materials. Otherwise it may cause fire. Don't turn the screws without purpose, especially the bolts with red mark.
	 Caution	Do not drop the lead wire stub or screw in the inverter. Otherwise it may damage the inverter. Install the inverter in the environment with less vibration and no direct sunlight. When more than two inverters are to be installed in one cabinet, pay attention to the installation location to ensure the heat dissipation effect.

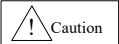
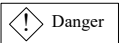
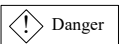
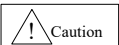
During wiring		<p>The device must be installed by professional electric operator, or it will have unexpected danger.</p> <p>There must be breaker between the inverter and the power source, or it may have fire risk.</p> <p>Please make sure the power supply is off before wiring, or it has the risk of electric shock.</p> <p>Please earth the inverter in normative way, or it has the risk of electric shock.</p>
		<p>Don't connect the input power supply to the output terminals (U,V,W) of the inverter. Pay attention to the marks of the wiring terminals so as to avoid the wire misconnect. Or it will cause damage to the inverter.</p> <p>The brake resistance cannot be directly connected between the DC bus (+),(-) terminals. Otherwise it may cause fire!</p> <p>Please refer to the manual to choose right wire diameter, or it may have accident.</p>
Before power -on		<p>Please confirm whether the power voltage class is consistent with the rated voltage of the inverter; whether the wiring position of the input terminals (R, S, T) and the output terminals (U, V, W) are correct; Check carefully whether the external circuit is short circuited and whether the connecting line is firm. Otherwise it may damage the inverter.</p> <p>There is no need to do withstand voltage test on any part of the inverter, because it has been tested before the delivery, otherwise it may cause accident.</p>
		<p>It must have the cover plate ready on the machine before connect to the power, or it will cause electric shock.</p> <p>All the wiring of the peripheral device must follow the instruction of the manual which has provided the circuit illustration of the wiring way. Otherwise it may cause accident.</p>
During power -on		<p>Don't open the cover plate after connection to the power resource. Or it has danger of electric shock.</p> <p>Don't touch any terminals regardless of input or output side, or it has danger of electric shock.</p>
		<p>If you need to record the running parameter, pay attention that the running motor may have the risk to hurt people. Or it may cause accident.</p>

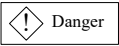
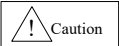
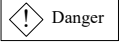
During the operation		<p>Detection of signals during the operation shall only be conducted by qualified technician. Otherwise, personal injury or equipment damage may be caused.</p> <p>Do not touch the fan or discharge resistor to sense the temperature, or you may get burnt.</p>
		<p>During the operation of the inverter, keep items from falling into the equipment, or it may damage the equipment.</p> <p>Do not start and shut down the inverter by connecting and disconnecting the contactor, or it may damage the equipment.</p>
Maintenance		<p>The inverter shall be repaired and maintained only by the qualified person who has been trained professionally, or it may cause personal injury or equipment damage.</p> <p>Do not repair and maintain the equipment with power-on, or there will be danger of electric shock.</p> <p>Only more than 10 minutes after you shut down the power supply on the input side can you start to repair or maintain the inverter, otherwise, the residual charge on the capacitor may cause personal injury.</p>

1.2 Attention Items

1.2.1 Motor Insulation Inspection

When the motor is used for the first time, or when the motor is reused after being kept, or when periodical inspection is performed, it shall conduct motor insulation inspection so as to avoid damaging the inverter because of the insulation failure of the motor windings. The motor wires must be disconnected from the inverter during the insulation inspection. It is recommended to use the 500V mega meter, and the insulating resistance measured shall be at least 5MΩ.

1.2.2 Thermal Protection of the Motor

If the ratings of the motor does not match those of the inverter, especially when the rated power of the inverter is higher than the rated power of the motor, the relevant motor protection parameters in the in the inverter shall be adjusted, or thermal relay shall be mounted to protect the motor.

1.2.3 Running with Frequency higher than Standard Frequency

This inverter can provide output frequency of 0Hz to 1200Hz. If the user needs to run the inverter with frequency of more than 50Hz, please take the resistant pressure of the mechanical devices into consideration.

1.2.4 Vibration of Mechanical Device

The inverter may encounter the mechanical resonance point at certain output frequencies, which can be avoided by setting the skip frequency parameters in the inverter.

1.2.5 Motor Heat and Noise

Since the output voltage of inverter is PWM wave and contains certain harmonics, the temperature rise, noise and vibration of the motor will be higher than those when it runs at standard frequency.

1.2.6 Voltage-sensitive Device or Capacitor Improving Power Factor at the Output Side

Since the inverter output is PWM wave, if the capacitor for improving the power factor or voltage-sensitive resistor for lightning protection is mounted at the output side, it is easy to cause instantaneous over current in the inverter, which may damage the inverter. It is recommended that such devices not be used.

1.2.7 Switching Devices like Contactors Used at the Input and Output terminal

If a contactor is installed between the power supply and the input terminal of the inverter, it is not allowed to use the contactor to control the startup/stop of the inverter. If use of such contactor is unavoidable, it shall be used with interval of at least one hour. Frequent charge and discharge will reduce the service life of the capacitor inside the inverter. If switching devices like contactor are installed between the output end of the inverter and the motor, it shall ensure that the on/off operation is conducted when the inverter has no output. Otherwise the modules in the inverter may be damaged.

1.2.8 Operating beyond the rated voltage range

It's not proper to use the inverter beyond the voltage range that specified in the instruction manual, or it's easy to damage the inner components of the inverter. Please use a proper step-up or step-down device to deal with the power supply before connecting to the inverter if it's necessary.

1.2.9 Change Three-phase Input to Two-phase Input

It is not allowed to change the SSI series three-phase inverter into two-phase one. Otherwise, it may cause fault or damage to the inverter.

1.2.10 Lightning Impulse Protection

The series inverter has lightning over current protection device, and has certain self-protection capacity against the lightning. In applications where lightning occurs frequently, the user shall install additional protection devices at the front-end of the inverter.

1.2.11 Altitude and Derating

In areas with altitude of more than 1,000 meters, the heat sinking effect of the inverter may turn poorer due to rare air. Therefore, it needs to derate the inverter for use. Please contact our company for technical consulting in case of such condition.

1.2.12 Certain Special Use

If the user needs to use the inverter with the methods other than the recommended wiring diagram in this manual, such as shared DC bus, please consult our company.

1.2.13 Note of Inverter Disposal

The electrolytic capacitors on the main circuit and the PCB may explode when they are burnt. Emission of toxic gas may be generated when the plastic parts are burnt. Please dispose the inverter as industrial wastes.

1.2.14 Adaptable Motor

1) The standard adaptable motor is four-pole squirrel-cage asynchronous induction motor. If such motor is not available, be sure to select adaptable motors in according to the rated current of the motor. In applications where drive permanent magnetic synchronous motor is required, please consult our company;

2) The cooling fan and the rotor shaft of the non-variable-frequency motor adopt coaxial connection. When the rotating speed is reduced, the cooling effect will be poorer. Therefore, a powerful exhaust fan shall be installed, or the motor shall be replaced with variable-frequency motor to avoid the over heat of the motor.

3) Since the inverter has built-in standard parameters of the adaptable motors, it is necessary to perform motor parameter identification or modify the default values so as to comply with the actual values as much as possible, or it may affect the running effect and protection performance;

4) The short circuit of the cable or motor may cause alarm or explosion of the inverter. Therefore, please conduct insulation and short circuit test on the newly installed motor and cable. Such test shall also be conducted during routine maintenance. Please note that the inverter and the test part shall be completely disconnected during the test.

Chapter 2 Product Information

2.1 Naming Rules

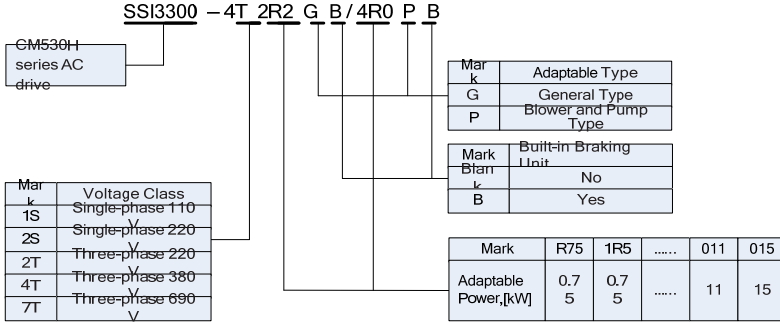

Fig.2-1 Naming Rules

2.2 Nameplate



Fig.2-2 Nameplate

2.3 SSI3300 Inverter Series

Tab.2-1 models and technical data of SSI3300

Model	Input voltage	Input current (A)	Output current (A)	Matched motor (kW)
SSI3300-2S0R4G	Single phase: 220V Range: -15%~20%	5.4	2.3	0.4
SSI3300-2S0R75G		8.2	4.0	0.75
SSI3300-2S1R5G		14.0	7.0	1.5
SSI3300-2S2R2GB		23.0	9.6	2.2
SSI3300-4T0R75GB	Three phase: 380V Range: -15%~20%	3.4	2.1	0.75
SSI3300-4T1R5GB/2R2PB		5.0/5.8	3.8/5.1	1.5/2.2
SSI3300-4T2R2GB/4R0PB		5.8/14.6	5.1/9.0	2.2/4.0
SSI3300-4T4R0GB/5R5PB		10.5/14.6	9.0/13.0	4.0/5.5
SSI3300-4T5R5GB/7R5PB		14.6/20.5	13.0/17.0	5.5/7.5
SSI3300-4T7R5GB/9R0PB		20.5/22.0	17.0/20.0	7.5/9.0
SSI3300-4T9R0GB/011PB		22.0/26.0	20.0/25.0	9.0/11.0
SSI3300-4T011GB/015PB		26.0/35.0	25.0/32.0	11.0/15.0
SSI3300-4T015GB/018PB		35.0/38.5	32.0/37.0	15.0/18.5
SSI3300-4T018GB/022PB		38.5/46.5	37.0/45.0	18.5/22.0
SSI3300-4T022GB/030PB		46.5/62.0	45.0/60.0	22.0/30.0
SSI3300-4T030G/037P		62.0/76.0	60.0/75.0	30.0/37.0
SSI3300-4T037G/045P		76.0/92.0	75.0/90.0	37.0/45.0
SSI3300-4T045G/055P		92.0/113.0	90.0/110.0	45.0/55.0
SSI3300-4T055G/075P		113.0/157.0	110.0/152.0	55.0/75.0
SSI3300-4T075G/090P		157.0/180.0	152.0/176.0	75.0/93.0
SSI3300-4T090G/110P		180.0/214.0	176.0/210.0	93.0/110.0
SSI3300-4T110G/132P		214.0/256.0	210.0/253.0	110.0/132.0
SSI3300-4T132G/160P		256.0/307.0	253.0/304.0	132.0/160.0
SSI3300-4T160G/185P		307.0/345.0	304.0/340.0	160.0/185.0
SSI3300-4T185G/200P		345.0/385.0	340.0/380.0	185.0/200.0
SSI3300-4T200G/220P		385.0/430.0	380.0/426.0	200.0/220.0
SSI3300-4T220G/250P		430.0/468.0	426.0/465.0	220.0/250.0
SSI3300-4T250G/280P		468.0/525.0	465.0/520.0	250.0/280.0
SSI3300-4T280G/315P		525.0/590.0	520.0/585.0	280.0/315.0
SSI3300-4T315G/355P		590.0/665.0	585.0/650.0	315.0/355.0
SSI3300-4T355G/400P		665.0/785.0	650.0/725.0	355.0/400.0
SSI3300-4T400G/450P		785.0/883.0	725.0/820.0	400.0/450.0

2.4 Technical Specification

Item		Specifications
Main control Functions	Maximum frequency	Vector control: 0~600Hz VF control:0~1200Hz
	Carrier Frequency	1k ~ 15kHz; the carrier frequency will be automatically adjusted according to the load characteristics.
	Input frequency resolution	Digital setting: 0.01Hz Analog setting: maximum frequency ×0.1%
	Control mode	Open loop vector control ; V/F control.
	Start-up torque	Mode G machine: 0.5Hz/180% (open loop vector control) Mode P machine: 0.5Hz/120% (Open loop vector control)
	Speed adjustment range	1: 200 (Open loop Vector flux control)
Main control Functions	Stable speed Precision	Open loop Vector flux control: $\leq \pm 0.5\%$ (rated synchronous speed)
	Stabilization of speed control	Open loop Vector flux control: $\leq \pm 0.3\%$ (rated synchronous speed)
	Torque response	$\leq 40\text{ms}$ (Open magnetic flux vector control)
	Overload capacity	Mode G machine: 150% rated current 60s; 180% rated current 5s Mode P machine: 130% rated current 60s; 150% rated current 5s
	Torque boost	Automatic torque boost; manual torque boost 0.1% to 30.0%
	V/F curve	Linear V/F, Multi-point V/F, and Square V/F
	Speed-up and Speed-down curve	Straight line or S curve speed-up and speed-down mode; four kinds of speed-up and speed-down time; Speed-up and speed-down time ranges from 0.0s to 3000.0s
	DC brake	DC brake frequency: 0.00Hz ~ maximum frequency; brake time: 0.0s ~ 36.0s, and brake current value: 0.0% to 100.0%.
	Jog control	Jog frequency range:0.00Hz ~ 50.00Hz; Jog speed-up/speed-down time: 0.0s ~ 3000.0s.
	Simple PLC and multi-speed running	It can realize a maximum of 16 segments speed running via the built-in PLC or control terminal.
Built-in PID	It is easy to realize process-controlled close loop control	

Item	Specifications	
		system.
	(AVR) Automatic voltage regulation	It can keep constant output voltage automatically in case of change of mains voltage.
	Torque limit and control	"Shovel" characteristics, automatic limit on the torque on running time, preventing frequent over-current trip; closed loop vector mode can realize the torque control
Customized Functions	Peripherals self-detection upon power-on	It can conduct safety detections on the peripherals upon power-on, including earth and short circuit detections.
	Shared DC bus function	It can realize the function that multiple inverters share the DC bus.
	JOG key	Programmable key: Select the forward and reverse rotations/jog operation command.
Customized Functions	Traverse frequency control	Multiple triangular-wave frequency control function.
	Fast current limit function	With fast current limit algorithm built in to reduce the probability of over-current alarm; to improve the anti-jamming capacity of the whole machine.
	Timed control	Timing control function: Setting time range from 0h to 65535h.
	Keyboard extension line standardization	Customers can use standard cable to extend the keyboard
Operation Function	Running command channel	Three types of channels: operation panel given, control terminal given and serial communication port given. These channels can be switched in various ways.
	Frequency source	Ten types of frequency sources in total: digital given, analog voltage given, analog current given, pulse given, and serial port given. It can be switched in various ways.
	Auxiliary frequency source	Ten types of auxiliary frequency sources in total. It can implement micro tuning and synthesis of auxiliary frequency.
	Input terminal	Five digital input terminals, and seven terminals in maximum (AI1, AI2 can be used as DI terminals), it has compatibility to PNP or NPN input method. Two analog input terminals, in which AI1 only be used for voltage input, and AI2 can be used as voltage or current input.

Item	Specifications	
	Output terminal	One digital output terminal (bipolar output) Two relay output terminal Two analog output terminals, with optional 0/4mA to 20mA or 0/2V to 10V. It can realize the output of set frequency, output frequency and rotation speed etc.
Display and Keyboard Operate	LED display	Display parameter
	LCD display	Selective parts, Chinese/English to suggest the operation content
	LCD Parameter copy	Use LCD parameter special copy keyboard can copy the parameter quickly
	Key lock and function choose	Lock part of the keyboard or the whole keyboard, definite the function range of some keys to avoid mis-operation.
Protection and select accessories	protection function	Short circuit detective of power-on motor, input and output open-phase protection, over-current protection, overvoltage protection, under-voltage protection, over-heat protection, over-load protection etc.
	Selective accessories	LCD operation panel, brake group etc.
Environment	Suitable place	Indoor environment which is against from direct sunlight, dust, corrosive gas, combustible gas, oil mist, vapor, water drop and salt.
	Altitude	Less than 1000m
	Ambient Temperature	-10℃ ~ +50℃ (derating is required if the natural temperature range is 40℃ ~ 50℃)
	Humidity	Less than 95%RH, no condensing water drops
	Vibration	Less than 5.9m/ s ² (0.6g)
	Storage temperature	-20℃ ~ +60℃
	Class of pollution	2
Product Standard	Safety standard	IEC61800-5-1:2007
	EMC standard	IEC61800-3:2005

2.5 Physical Appearance and Dimensions of Mounting Hole

2.5.1 Product Appearance

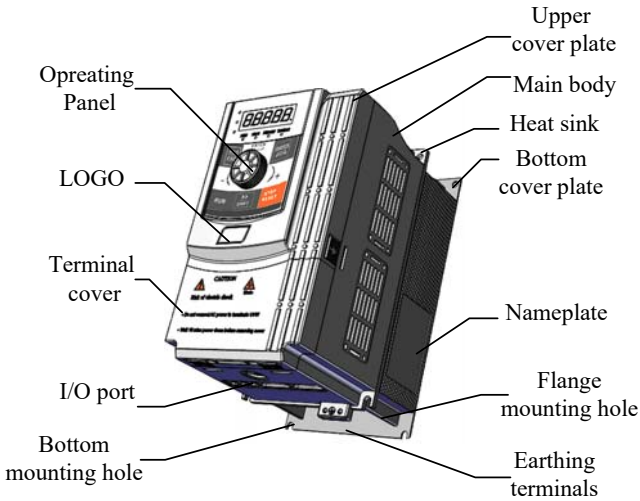

Physical appearance of plastic structure

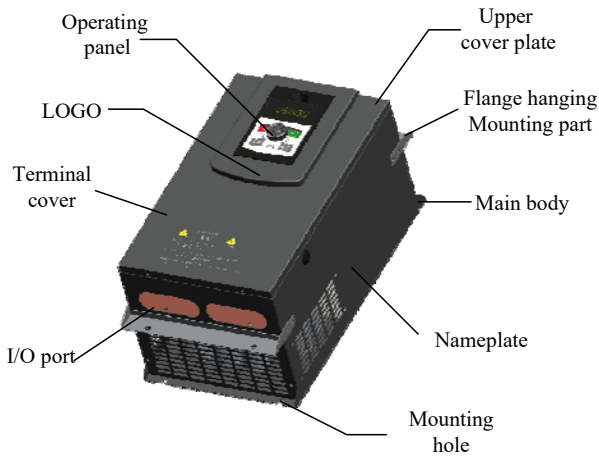

Physical appearance of sheet metal structure

Fig.2-3 physical appearance of the series

2.5.2 SSI3300 Mounting Hole Dimensions(mm)

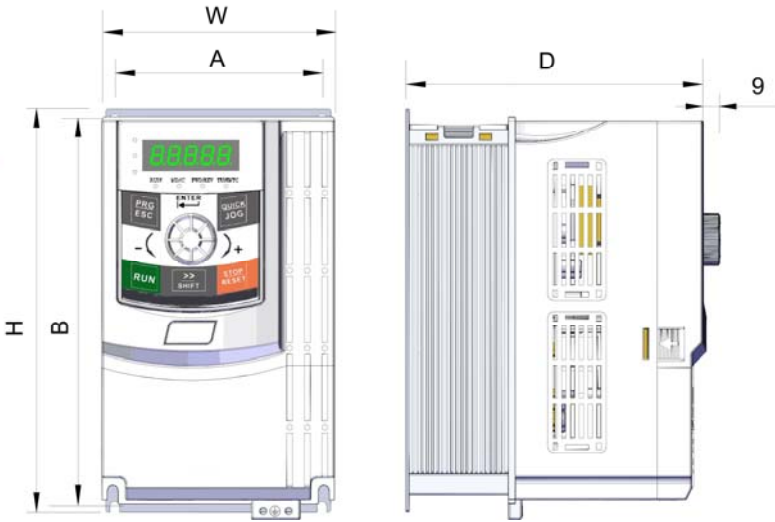

Fig.2-4 Installation dimensions of plastic mode below 7.5 KW

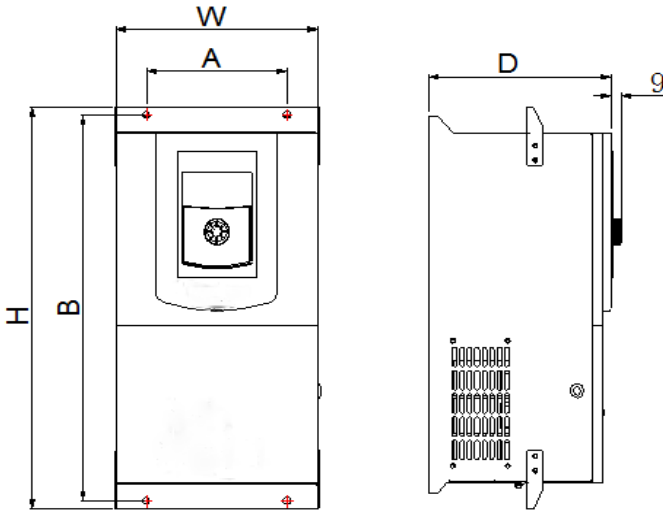

Fig.2-5 Installation dimensions of metal mode within 11~37KW

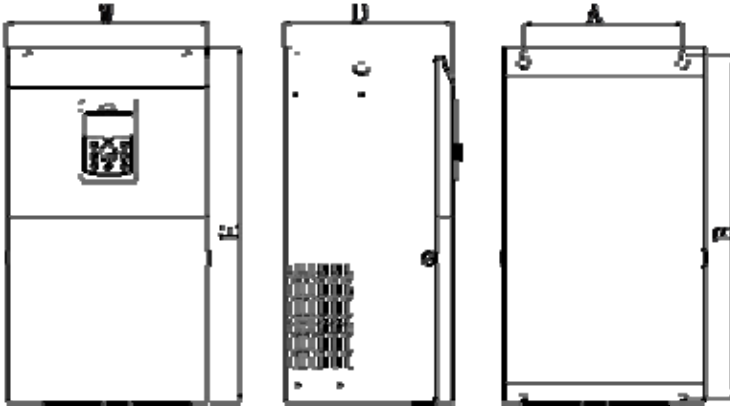

Fig.2-6 appearance and install dimension of inverter within 45KW~132KW

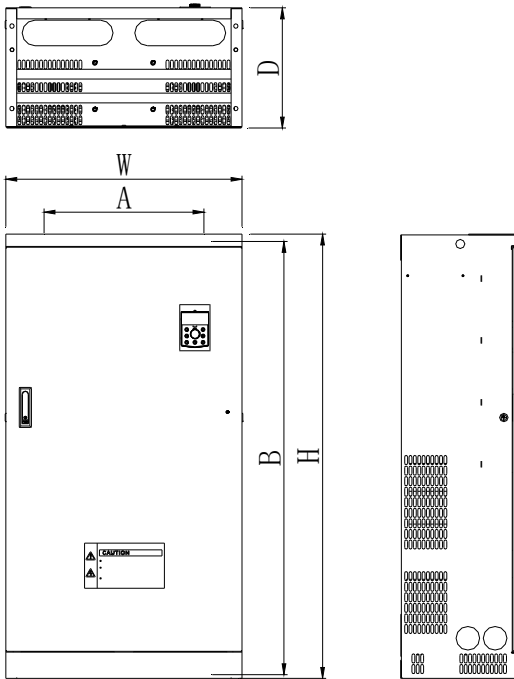
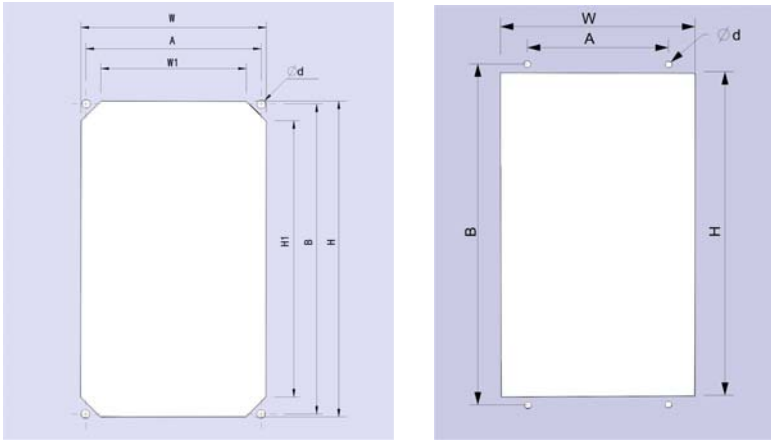

Fig2-7 Installation dimensions of metal mode above160KW

Tab.2-3 mounting hole dimensions of SSI3300

Model	Mounting hole		Physical dimension			Diameter of mounting hole (mm)
	A (mm)	B (mm)	H (mm)	W (mm)	D (mm)	
SSI3300-2S0R4G	78	162	172.5	96	141	Φ4.5
SSI3300-2S0R75G						
SSI3300-2S1R5G						
SSI3300-2S2R2GB	100	199	206	119	154	Φ5
SSI3300-4T0R75GB	78	162	172.5	96	141	Φ4.5
SSI3300-4T1R5GB/2R2PB						
SSI3300-4T2R2GB/4R0PB	100	199	206	119	154	Φ5
SSI3300-4T4R0GB/5R5PB						
SSI3300-4T5R5GB/7R5PB	120	260	268	139	155.5	Φ6
SSI3300-4T7R5GB/9R0PB						
SSI3300-4T9R0GB/011PB	150	314	324	188	188	Φ6
SSI3300-4T011GB/015PB						
SSI3300-4T015GB/018PB						
SSI3300-4T018GB/022PB	165	372	383	215	200	Φ6
SSI3300-4T022GB/030PB						
SSI3300-4T030G/037P	200	436	449	260	209	Φ7
SSI3300-4T037G/045P						
SSI3300-4T045G/055P	245	531	550	310	260	Φ10
SSI3300-4T055G/075P						
SSI3300-4T075G/090P	280	561	580	350	267	Φ10
SSI3300-4T090G/110P						
SSI3300-4T110G/132P	320	695	715	430	295	Φ10
SSI3300-4T132G/160P						
SSI3300-4T160G/185P	360	973	1000	470	318	Φ12
SSI3300-4T185G/200P						
SSI3300-4T200G/220P	380	1060	1088	520	338	Φ12
SSI3300-4T220G/250P						
SSI3300-4T250G/280P	440	1190	1220	650	330	Φ12
SSI3300-4T280G/315P						
SSI3300-4T315G/355P	500	1255	1288	720	400	Φ14
SSI3300-4T355G/400P						
SSI3300-4T400G/450P						



Tab.2-4 Wall-mounted mode installation dimensions of SSI3300 under 22KW

Model	Mounting hole		Wall-mounted hole dimension				Diameter of mounting hole (mm)
	A (mm)	B (mm)	H (mm)	H1 (mm)	W (mm)	W1 (mm)	
SSI3300-2S0R4G	88	157	160	140	93	73	Φ4.5
SSI3300-2S0R75G							
SSI3300-2S1R5G							
SSI3300-2S2R2GB	108	185	192	168	116	92	Φ4.5
SSI3300-4T0R75GB	88	157	160	140	93	73	Φ4.5
SSI3300-4T1R5GB/2R2PB							
SSI3300-4T2R2GB/4R0PB	108	185	192	168	116	92	Φ4.5
SSI3300-4T4R0GB/5R5PB							
SSI3300-4T5R5GB/7R5PB	128	239	245	221	136	112	Φ5.5
SSI3300-4T7R5GB/9R0PB							
SSI3300-4T9R0GB/011PB	140	341	311	/	191	/	Φ8
SSI3300-4T011GB/015PB							
SSI3300-4T015GB/018PB							
SSI3300-4T018GB/022PB	150	392	415	/	219	/	Φ8
SSI3300-4T022GB/030PB							

2.5.3 Mounting dimension of outer keyboard with plate and those without plate

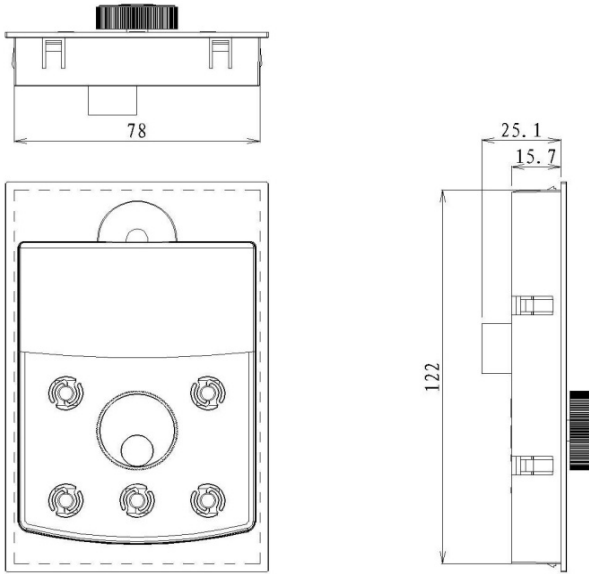

Fig.2-7 outer keyboard with plate installation dimension

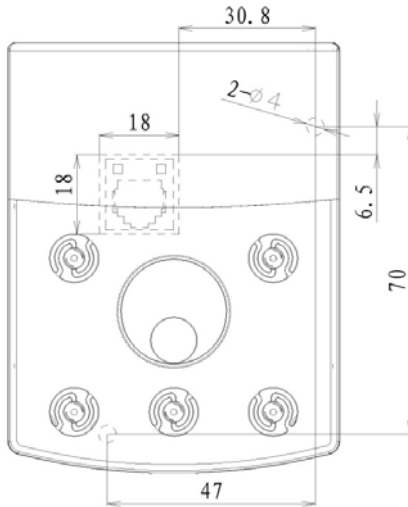

Fig.2-8 outer keyboard without plate installation dimension

2.6 Optional Parts

If the user needs such optional parts, please specify when placing the order.

Tab.2-6 SSI3300 Inverters Optional Parts

Name	Model	Function	Remarks
Built-in brake unit	The letter “B” attached behind the product model	Braking	Built-in as standard
External LED operating panel	SSI3300-LED	External LED display and keyboard	SSI series universal The RJ45 interface
External LCD operating panel	SSI3300 -LCD	External LCD display and keyboard	The RJ45 interface
External LED2 operating panel	SSI3300 -LED2	The copy function keyboard with parameters	SSI series universal RJ45 interface
Extension cable	SSI3300 -CAB	Standard 8 core cable, can and SSI3300-LED, SSI3300-LCD, SSI3300-LED2 connection	Providing 1 meters, 3 meters, 5 meters, 10 meters, totally 4 kinds of specifications

2.7 Routine Repair and Maintenance of Inverter

2.7.1 Routine Repair

The influence of the ambient temperature, humidity, dust and vibration will cause the aging of the devices in the inverter, which may cause potential fault of the inverter or reduce the service life of the inverter. Therefore, it is necessary to carry out routine and periodical maintenance on the inverter.

Routine inspection Items include:

- 1) Whether there is any abnormal change in the running sound of the motor;
- 2) Whether the motor has vibration during the running;
- 3) Whether there is any change to the installation environment of the inverter;
- 4) Whether the inverter cooling fan works normally;
- 5) Whether the inverter has over temperature;

Routine cleaning:

The inverter shall be kept clean all the time.

The dust on the surface of the inverter shall be effectively removed, so as to prevent the dust entering the inverter. Especially the metal dust is not allowed.

The oil stain on the inverter cooling fan shall be effectively removed.

2.7.2 Periodic Inspection

Please perform periodic inspection on the places where the inspection is a difficult thing.

Periodic inspection Items include:

- 1) Check and clean the air duct periodically;
- 2) Check if the screws are loosened;
- 3) Check if the inverter is corroded;

- 4) Check if the wire connector has arc signs;
- 5) Main circuit insulation test;

Remainder: When using the megameter (DC 500V megameter recommended) to measure the insulating resistance, the main circuit shall be disconnected with the inverter. Do not use the insulating resistance meter to control the insulation of the circuit. It is not necessary to conduct the high voltage test (which has been completed upon delivery).

2.7.3 Replacement of Vulnerable Parts for Inverter

The vulnerable parts of the inverter include cooling fan and filter electrolytic capacitor, whose life depends on the operating environment and maintenance status. Common service life:

Part name	Life time
Fan	2 to 3 years
Electrolytic capacitor	4 to 5 years

The user can determine the term for replacement according to the running time.

1) Cooling fan

Possible causes for damage: bearing wearing and blade aging.

Criteria: Whether there is crack on the blade and whether there is abnormal vibration noise upon startup.

2) Filter electrolytic capacitor

Possible causes for damage of filter electrolytic capacitor: Poor input source quality, high ambient temperature, frequent load jumping and burning electrolyte.

Criteria: Whether there is liquid leakage, whether the safe valve has projected, measure the static capacitance, and measure the insulating resistance.

2.7.4 Storage of Inverter

Attention shall be paid to the following points for the temporary and long-term storage of the inverter:

- 1) Place the inverter back into the packing box following the original package;
- 2) Long-term storage will degrade the electrolytic capacitor. The product shall be powered up once every 2 years, and the power-up time shall be no less than 5 hours. The input voltage shall be increased slowly to the rated value with the regulator.

2.8 Warranty of Inverter

Free repair warranty is just for inverter itself.

1. Warranty instruction of product for domestic use.

- ① guarantee for repair, exchange and return of the inverter within 1 month after the delivery.
- ② guarantee for repair and exchange within 3 months after the delivery.
- ③ guarantee for repair with 15 months after the delivery or within 18 months after the date of production as indicated on the barcode.

2. Products exported to overseas area (excluding domestic area) have repair warranty on the purchase place with 6 month after the delivery.

3. Reasonable fees will be charged due to the expiration of the warranty period.

4. Reasonable fees will be charged for the following situations within the warranty period.

① The machine is damaged for the reason that the user didn't operate it according to the manual.

② The damage is caused by force majeure like flood, fire or abnormal voltage etc.

③ The damage is caused for the inverter been used in abnormal function.

④ The P-type (fan, water bump type) inverter is used as the G-type (general type).

⑤ Tear off the nameplate and serial number without authorization.

5. We only take responsibility for item 1 or item 2 if there were any product accident, for more compensation, please insure for the goods previously for property insurance.

The service charge is counted according to the standard rules made by the company; the contract takes the priority if there is any agreement previous.

2.9 Guide to Select Brake Components

What in below Tab.2-6 are the guide data, the user can choose different resistance and power according to the practical situation, (the resistance value must not less than the recommended one; the power value can be more) the brake resistance should be chosen according to the real power of the motor when used in practical system. It is related to system inertia, speed decelerating time and potential energy load etc, the customer should choose it based on the real circumstance. The bigger inertia of the system; the shorter time of speed decelerating; the more frequent of the brake; the bigger power and smaller resistance of the brake resistor need to be with.

2.9.1 How to choose the resistance

When braking, almost all the recovery energy of the motor is spent on the braking resistance. It follows the formula: $U^2/R=P_b$

U---the braking voltage of the stable braking system (the value is different in different system. Generally for 380VAC, the value is 700V)

P_b ---the braking power

2.9.2 How to choose the power of the braking resistor

The power of the braking resistor is same as the braking power theoretically, but taking into consideration that the derating is 70%. It follows the formula: $0.7*P_r=P_b*D$

P_r ---the power of the braking resistor

D---the braking ratio (the ratio which the reactivation process divides the whole working process), generally take 10% as its value. You can refer to the details in below chart.

Application industry	elevator	Winding and unwinding machine	centrifuge	Accidental braking load
ratio	20% ~30%	20~30%	50%~60%	5%

Tab.2-7 selection of SSI3300 inverter brake components

Inverter model	Braking torque 150%,5S recommended resistance value, power and brake unit model	Braking torque 100%,15S recommended resistance value, power and brake unit model	Braking torque 50%,15S recommended resistance value, power and brake unit model
SSI3300-2S0R4G	≥220Ω, 0.4KW Optional brake unit	≥300Ω, 0.3KW Optional brake unit	≥300Ω, 0.3KW Optional brake unit
SSI3300-2S0R75G	≥150Ω, 0.6KW Optional brake unit	≥150Ω, 0.6KW Optional brake unit	≥300Ω, 0.3KW Optional brake unit
SSI3300-2S1R5G	≥60Ω, 1KW Optional brake unit	≥100Ω, 0.8KW Optional brake unit	≥150Ω, 0.6KW Optional brake unit
SSI3300-2S2R2GB	≥40Ω, 1.2KW build-in brake unit	≥60Ω, 1KW build-in brake unit	≥150Ω, 0.6KW build-in brake unit
SSI3300-4T0R75GB	≥300Ω, 0.3KW build-in brake unit	≥300Ω, 0.3KW build-in brake unit	≥300Ω, 0.3KW build-in brake unit
SSI3300-4T1R5GB/2R2PB	≥150Ω, 0.5KW build-in brake unit	≥220Ω, 0.4KW build-in brake unit	≥300Ω, 0.3KW build-in brake unit
SSI3300-4T2R2GB/4R0PB	≥100Ω, 0.8KW build-in brake unit	≥130Ω, 0.6KW build-in brake unit	≥150Ω, 0.5KW build-in brake unit
SSI3300-4T4R0GB/5R5PB	≥75Ω, 1.0KW build-in brake unit	≥100Ω, 0.8KW build-in brake unit	≥130Ω, 0.6KW build-in brake unit
SSI3300-4T7R5GB/9R0PB	≥60Ω, 1.2KW build-in brake unit	≥75Ω, 1.0KW build-in brake unit	≥100Ω, 0.8KW build-in brake unit
SSI3300-4T9R0GB/011PB	≥40Ω, 2KW build-in brake unit	≥50Ω, 1.5KW build-in brake unit	≥60Ω, 1.2KW build-in brake unit
SSI3300-4T011GB/015PB	≥30Ω, 4KW build-in brake unit	≥40Ω, 2KW build-in brake unit	≥50Ω, 1.5KW build-in brake unit
SSI3300-4T015GB/018PB	≥24Ω, 4KW build-in brake unit	≥30Ω, 4KW build-in brake unit	≥40Ω, 2KW build-in brake unit
SSI3300-4T018GB/022PB	≥13.6Ω, 8KW build-in brake unit	≥30Ω, 4KW build-in brake unit	≥40Ω, 2KW build-in brake unit
SSI3300-4T022GB/030PB	≥13.6Ω, 8KW Brake unit built-in as optional	≥24Ω, 6KW Brake unit built-in as optional	≥30Ω, 4KW Brake unit built-in as optional

Inverter model	Braking torque 150%,5S recommended resistance value, power and brake unit model	Braking torque 100%,15S recommended resistance value, power and brake unit model	Braking torque 50%,15S recommended resistance value, power and brake unit model
SSI3300-4T037G/045P	$\geq 10\Omega$, 12KW BR530-4T075	$\geq 24\Omega$, 6KW BR530-4T037	$\geq 24\Omega$, 6KW BR530-4T037
SSI3300-4T045G/055P	$\geq 6.8\Omega$, 12KW BR530-4T132	$\geq 10\Omega$, 12KW BR530-4T075	$\geq 13.6\Omega$, 8KW BR530-4T075
SSI3300-4T055G/075P			
SSI3300-4T075G/090P			
SSI3300-4T090G/110P	$\geq 2*6.8\Omega$, 12KW BR530-4T200	$\geq 6.8\Omega$, 12KW BR530-4T132	$\geq 6.8\Omega$, 12KW BR530-4T132
SSI3300-4T110G/132P			
SSI3300-4T132G/160P			
SSI3300-4T160G/185P	$\geq 3*6.8\Omega$, 12KW BR530-4T315	$\geq 2*6.8\Omega$, 12KW BR530-4T200	$\geq 2*6.8\Omega$, 12KW BR530-4T200
SSI3300-4T185G/200P			
SSI3300-4T200G/220P			
SSI3300-4T220G/250P	$\geq 3*6.8\Omega$, 12KW BR530-4T315	$\geq 2*6.8\Omega$, 12KW BR530-4T315	$\geq 2*6.8\Omega$, 12KW BR530-4T315
SSI3300-4T250G/280P			
SSI3300-4T280G/315P			
SSI3300-4T315G/355P	$\geq 5*6.8\Omega$, 20KW BR530-4T630	$\geq 4*6.8\Omega$, 20KW BR530-4T450	$\geq 3*6.8\Omega$, 20KW BR530-4T450
SSI3300-4T355G/400P			
SSI3300-4T400G/450P			

Attention:

1. The braking resistance value can't be less than the recommended data, if it exceeding the recommended data it may damage the braking unit.
2. What's in the table "×2" means 2 brake resistor used in parallel, "×3" means 3 brake resistor used in parallel. For others can be done in the same manner.
3. It's the standard build-in brake unit inverter model if there is a "B" following after the model name, if not, no build-in brake unit. Please choose the corresponding brake unit model according to the brake torque.
4. 18.5~30KW selectable build-in brake unit of G type inverter. Please declare it on the order requirement that you need the standard configuration without brake unit if it's needed.
5. What in the tale "5S, 15S" means the continuous braking time.

Chapter 3 Mechanical and Electrical Installation

3.1 Mechanical Installation

3.1.1 Installation environment

1) Ambient temperature: The ambient temperature exerts great influences on the service life of the inverter and is not allowed to exceed the allowable temperature range (-10 °C Celsius to 50 °C Celsius).

2) The inverter shall be mounted on the surface of incombustible articles, with sufficient spaces nearby for heat sinking. The inverter is easy to generate large amount of heat during the operation. The inverter shall be mounted vertically on the base with screws.

3) The inverter shall be mounted in the place without vibration or with vibration of less than 0.6G, and shall be kept away from such equipment as punching machine.

4) The inverter shall be mounted in locations free from direct sunlight, high humidity and condensate.

5) The inverter shall be mounted in locations free from corrosive gas, explosive gas or combustible gas.

6) The inverter shall be mounted in locations free from oil dirt, dust, and metal powder.

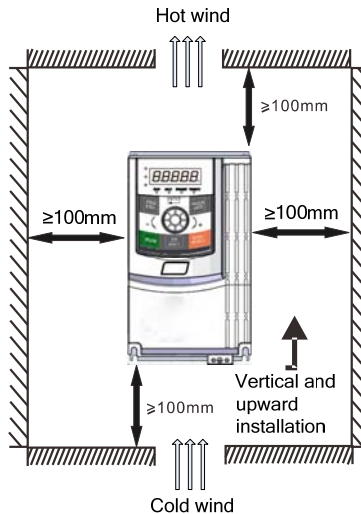

Fig.3-1 single one installation illustration

Tips: please use heat baffle showed in the picture when the inverters are mounted one in the top of the other one.

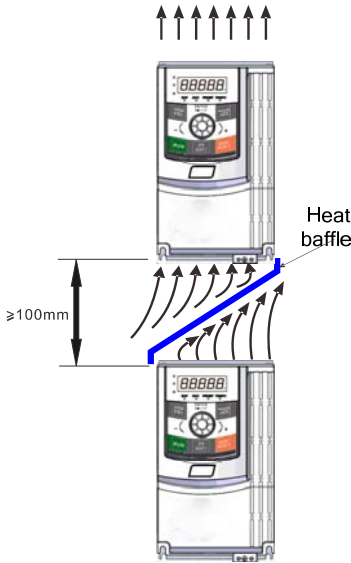

Fig.3-2 SSI3300 installation illustration

3.1.2 We should watch out the heat dissipation problem during installation. Pay attention to the following items:

1) Install the inverter vertically so that the heat may be expelled from the top. However, the equipment cannot be installed upside down. If there are multiple inverters in the cabinet, parallel installation is better. In the applications where up-down installation is required, please install the thermal insulating guide plate referring to the schematic diagrams for standalone installation and up-down installation.

2) The mounting space shall be as indicated as the above diagrams, so as to ensure the heat sinking space of the inverter. However, the heat sinking of other devices in the cabinet shall also be considered.

3) The installation bracket must be made of flame retardant materials.

4) In the applications where there are metal powders, it is recommended to install the radiator outside the cabinet. In this case, the space inside the sealed cabinet shall be large as much as possible.

3.1.3 Mechanical installation method and steps.

It has plastic and sheet metal structure of SSI3300 series.

1. Plastic structure wall-mounted installation

Installation instruction:

- 1) take off the backplane of the inverter;
- 2) place the inverter in the cabinet with right installation dimension and mounting holes, and fixed with screws (M4*12) and screw nuts (M4);
- 3) install back the backplane of the inverter;

Diameter of Wall-mounted holes is as table 2-4.

2. Sheet metal structure wall-mounted installation

Installation instruction:

- 1) install the flange hook to the top and the bottom of the inverter;
- 2) place the inverter in the cabinet with right installation dimension and mounting holes, and fixed with screws (M6) and screw nuts;

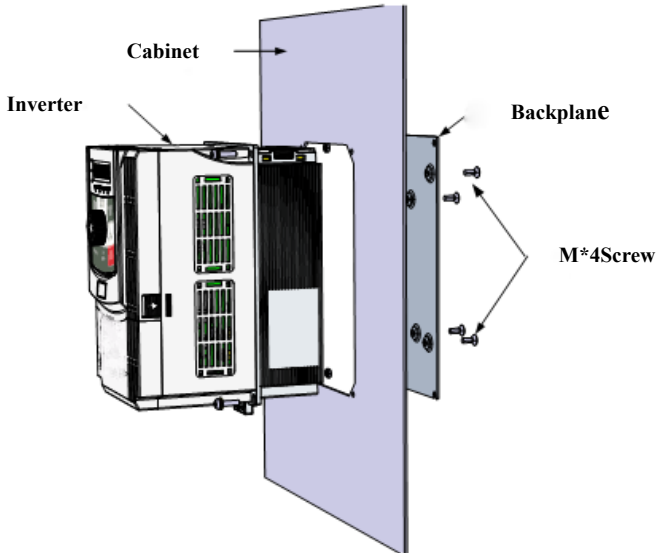

Fig.3-3. SSI3300 Wall-mounted installation instruction of plastic structure

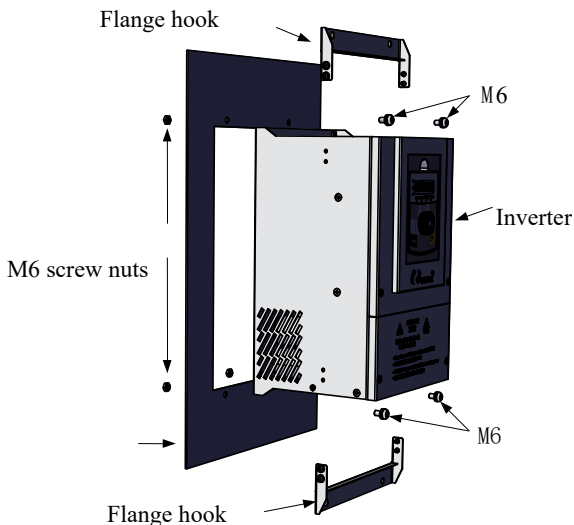
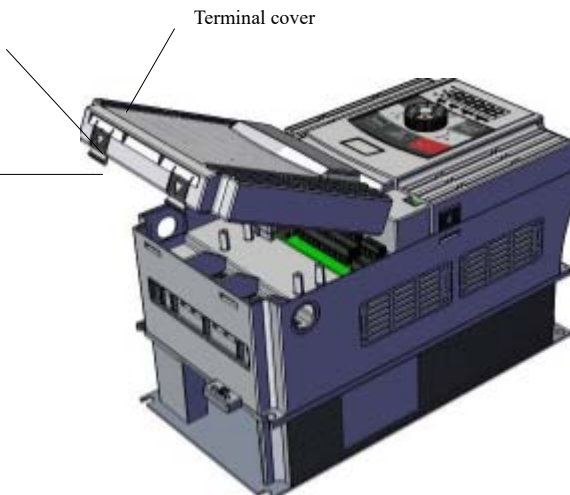

Fig.3-4 SSI3300 Wall-mounted installation instruction of sheet metal structure

3.1.4 Removal and installation of the terminal cover

SSI3300 series of inverters are with plastic shell, how to remove the terminal cover refers to Fig.3-5, you can use tools to push the hook of the cover to inside strongly until it's open.

1. Use tools to push the hook to inside strongly until it's open.
2. Grasp the edge of the cover and lift it upside.



3.2 Electrical Installation

3.2.1 Guide to choose peripheral electrical components

Tab.3-1 guide to choose peripheral electrical components of SSI3300

Inverter Model \ Hook groove	Circuit Breaker (MCCB) (A)	Contactor (A)	Input Side Main Circuit Wire (mm ²)	Output Side Main Circuit Wire (mm ²)	Control Circuit Wire (mm ²)	Earth Wire (mm ²)
SSI3300-2S0R4G	10	9	0.75	0.75	0.5	2.5
SSI3300-2S0R75G	16	12	0.75	0.75	0.5	2.5
SSI3300-2S1R5G	25	18	1.5	1.5	0.5	2.5
SSI3300-2S2R2GB	32	25	2.5	2.5	0.5	2.5
SSI3300-4T0R75GB	6	9	0.75	0.75	0.5	2.5
SSI3300-4T1R5GB/2R2PB	10	9	0.75	0.75	0.5	2.5
SSI3300-4T2R2GB/4R0PB	10	12	0.75	0.75	0.5	2.5
SSI3300-4T4R0GB/5R5PB	16	16	2.5	2.5	0.75	2.5
SSI3300-4T5R5GB/7R5PB	20	18	2.5	2.5	0.75	2.5
SSI3300-4T7R5GB/9R0PB	32	25	4.0	4.0	1.0	4
SSI3300-4T9R0GB/011PB	40	32	4.0	4.0	1.0	6
SSI3300-4T011GB/015PB	40	32	4.0	4.0	1.0	6
SSI3300-4T015GB/018PB	50	38	6.0	6.0	1.0	6
SSI3300-4T018GB/022PB	50	40	10	10	1.0	10
SSI3300-4T022GB/030PB	63	50	10	10	1.0	16
SSI3300-4T030G/037P	100	65	16	16	1.0	16
SSI3300-4T037G/045P	100	80	25	25	1.0	25
SSI3300-4T045G/055P	125	95	35	35	1.0	25
SSI3300-4T055G/075P	160	115	50	50	1.0	25
SSI3300-4T075G/090P	225	170	70	70	1.0	25
SSI3300-4T090G/110P	250	205	95	95	1.0	25
SSI3300-4T110G/132P	315	245	120	120	1.0	25
SSI3300-4T132G/160P	350	300	120	120	1.0	25
SSI3300-4T160G/185P	400	300	150	150	1.0	25
SSI3300-4T185G/200P	500	410	185	185	1.0	25
SSI3300-4T200G/220P	500	410	185	185	1.0	25

Inverter Model	Circuit Breaker (MCCB) (A)	Contactor (A)	Input Side Main Circuit Wire (mm ²)	Output Side Main Circuit Wire (mm ²)	Control Circuit Wire (mm ²)	Earth Wire (mm ²)
SSI3300-4T220G/250P	630	475	240	240	1.0	25
SSI3300-4T250G/280P	630	475	2×120	2×120	1.0	25
SSI3300-4T280G/315P	700	620	2×120	2×120	1.0	25
SSI3300-4T315G/355P	800	620	2×150	2×150	1.0	35
SSI3300-4T355G/400P	1000	800	2×185	2×185	1.0	35
SSI3300-4T400G/450P	1250	800	2×240	2×240	1.0	35

3.2.2 Using instruction of peripheral electrical components

Tab.3-2 Using instruction of the peripheral electrical components of SSI3300

Part Name	Installation Location	Function Description
Circuit breaker	The front-end of the input circuit	Disconnect the power supply in case of downstream equipment is over current.
Contactor	Between the circuit breaker and the inverter input side	Power-on and power-off operation of the inverter. Frequent power-on/power-off operation (more than 2 times per minute) on the inverter or direct start shall be avoided.
AC input Reactor	Input side of the inverter	1) Improve the power factor of the input side. 2) Eliminate the high order harmonics of the input side effectively, and prevent other equipment from damaging due to voltage waveform deformation. 3) Eliminate the input current unbalance due to the unbalance among the phase of input.
DC reactor	DC reactor is optional for 75KW~ 132KW SSI series inverter, but standard for the 160KW above.	1) Improve the power factor of the input side. 2) Eliminate the high order harmonics of the input side effectively, and prevent other equipment from damaging due to voltage waveform deformation.
EMC input Filter	Input side of the inverter	1) Reduce the external conduction and radiation interference of the inverter; 2) Reduce the conduction interference flowing from the power end to the inverter, thus

		improving the anti-interference capacity of the inverter.
AC output Reactor	Between the inverter output side and the motor, close to the inverter	<p>The inverter output side generally has higher harmonic. When the motor is far from the inverter, since there are many capacitors in the circuit, certain harmonics will cause resonance in the circuit and bring in the following results:</p> <ol style="list-style-type: none">1) Degrade the motor insulation performance and damage the motor for the long run.2) Generate large leakage current and cause frequent inverter protection action.3) In general, if the distance between the inverter and the motor exceeds 100 meters, output AC reactor shall be installed.

3.2.3 Typical wiring

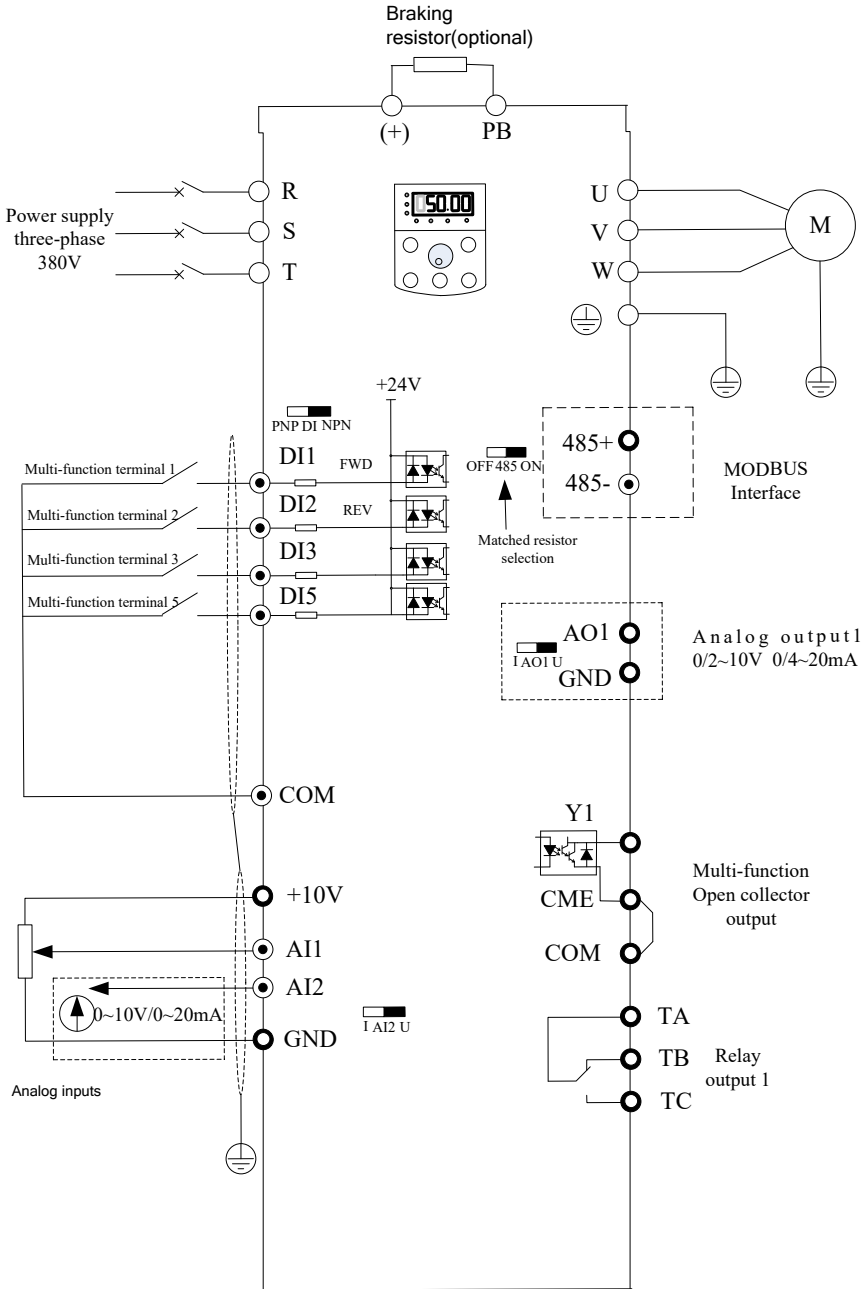

Fig.3-6 three-phase inverter under 1.5KW

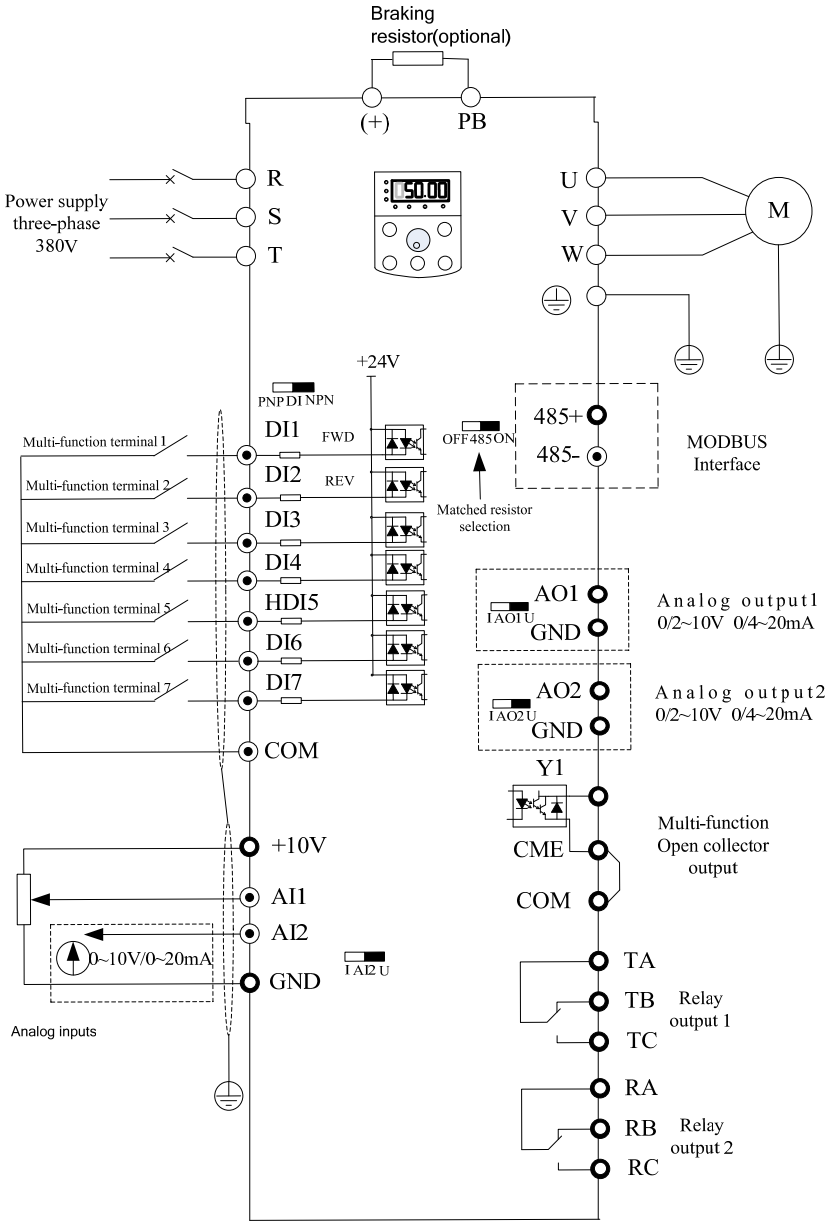

Fig.3-7 three-phase inverter under 22KW

Attention:

This figure is just for SSI3300-4TR75GB ~ SSI3300-4T022GB series of inverter (30~90kw brake unit is the selective part, please declare it in order request if it's needed.)

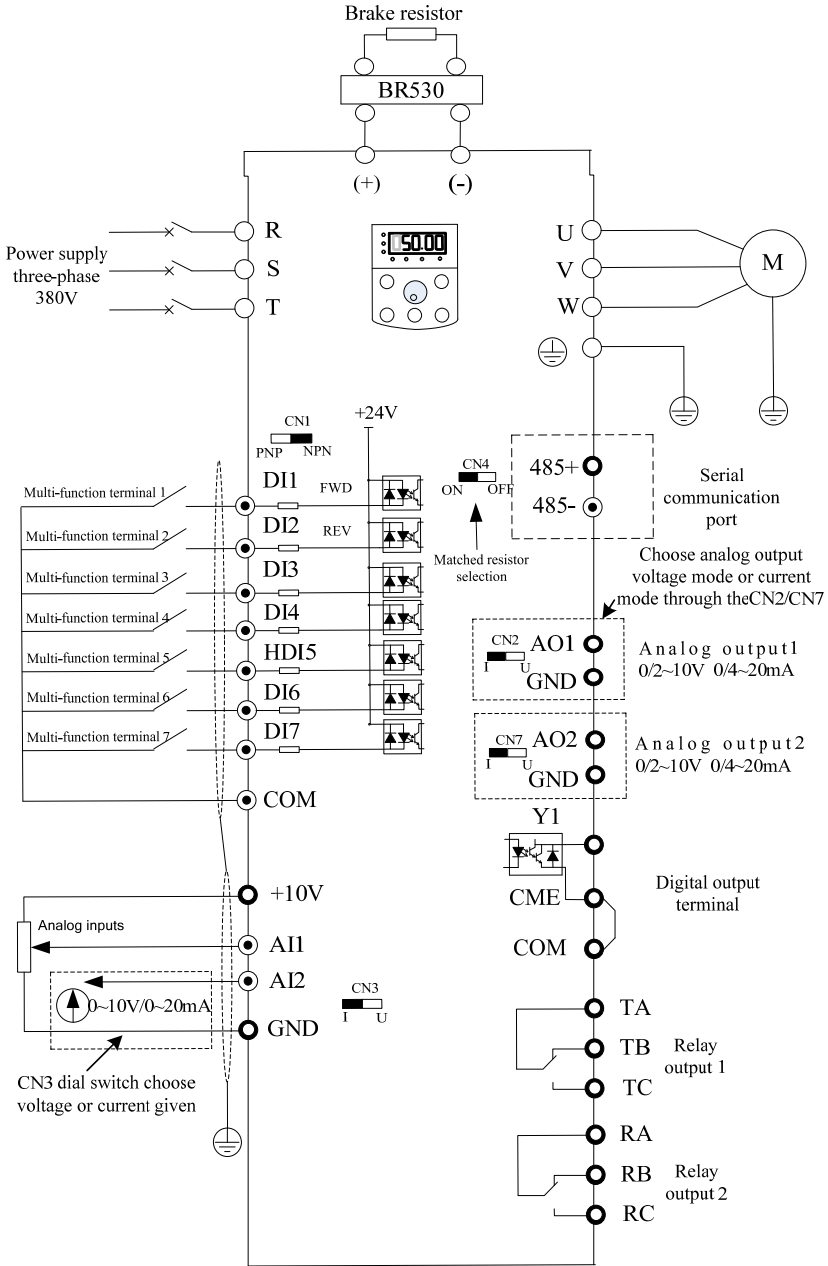

Fig.3-8 three-phase inverter within 30KW~55KW

Attention:

(30~90kw brake unit is the selective part, please declare it in order request if it's needed.)

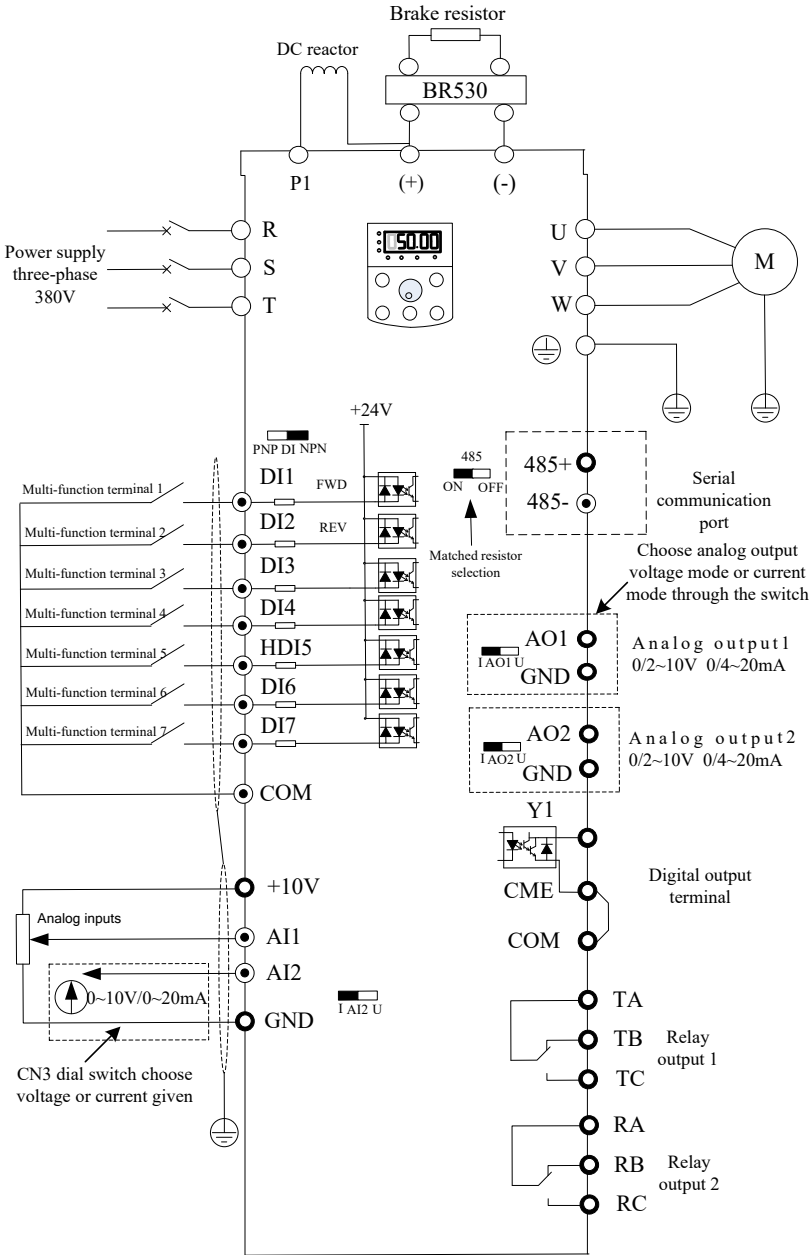



Fig.3-9 three-phase inverter above 75KW

Attention:

(30~90kw brake unit is the selective part, please declare it in order request if it's needed.)

3.2.4 Main circuit terminals and wiring

Main circuit terminals of single-phase

Terminal	Terminal Name	Description
L1, L2	Single-phase power supply input terminals	Connect to the single-phase 220 VAC power supply
P(+), (-)	Positive and negative terminals of DC bus	Common DC bus input point.
P(+), PB	Connecting terminals of braking resistor	Connect to a braking resistor
U, V, W	Output terminals	Connect to a three-phase motor.
	Grounding terminal	Must be grounded.

Main circuit terminals of three-phase

Terminal	Terminal Name	Description
R, S, T	Three-phase power supply input terminals	Connect to the three-phase AC power supply.
P(+), (-)	Positive and negative terminals of DC bus	Common DC bus input point.
P(+), PB	Connecting terminals of braking resistor	Connect to the braking resistor for the AC drive of 7.5 kW and below (220 V) and 18.5kW and below (other voltage classes).
U, V, W	Output terminals	Connect to a three-phase motor.
	Grounding terminal	Must be grounded.

Wiring precautions:

Input power supply L, N or R, S, T:

No phase sequence requirement in the input side wiring of the inverter.

DC bus P(+), (-):

Pay attention that there is remaining voltage on DC bus P(+), (-) just after a power failure, only wait until the power indicate LED is off and 10 minutes after the power off, can we start the wiring operation, or there is risk of electric shock.

The wire length of the brake unit should be no more than 10m, and we should use the twisted pair and tight wire for wiring.

Don't connect the brake resistor to the DC bus directly, or it may damages the inverter and cause fire.

Connection terminals of brake resistor P(+), PB

How to choose the brake resistor refer to the recommended value and the wiring distance should be less than 5m, or it may damage the inverter.

Output side of the inverter U, V, W

The capacitor or surge absorber can't be connected to the output side of the inverter, or it may damage the inverter.

If the motor cable is too long, for the influence of the distribute capacitance, it's easily to have electrical resonance, causing the damage of the insulation or large leakage current which make the inverter over-current protection. If the length of motor cable is more than 100m, a AC output reactor should be installed near the inverter.

3.2.5 Control circuit terminals and wiring

The control circuit terminals displayed as below:

GND	AO1	AO2	485-	DI1	DI2	DI3	DI4	HDI5	COM
10V	AI1	AI2	485+	CME	COM	Y1	DI6	DI7	24V

RA	RB	RC
TA	TB	TC

Three-phase above 380V 2.2KW

GND	AI1	AI2	DI1	DI2	DI3	DI5	COM
10V	AO1	485+	485-	CME	COM	Y1	24V

TA	TB	TC
----	----	----

Three-phase under 380V 1.5KW

☞ Function instruction of the control terminals

Tab.3-3 control interface function declaration of SSI3300

Category	Terminal	Terminal Name	Function Description
Power source	+10V-GND	External +10 V power supply	Provide +10 V power supply to external unit, maximum output current: 10 mA Generally, it provides power supply to external potentiometer with resistance range of 1–5 kΩ.
	+24V-COM	External +24 V power supply	Provide +24 V power supply to external unit. Generally, it provides power supply to DI/DO terminals and external sensors. Maximum output current: 200 mA
Analog input	AI1-GND	Analog input 1	1) Input voltage range: 0–10 VDC; 2) Impedance: 100kΩ
	AI2-GND	Analog input 2	1) Input range: 0–10 VDC/4–20 mA, decided by CN3 dial switches on the control board 2) Impedance: 100 kΩ (voltage input), 500 Ω (current input)
Digital input	DI1-COM	Digital input 1	1) Optical coupling isolation, compatible with dual-polarity input. Switch over
	DI2-COM	Digital input 2	

	DI3-COM	Digital input 3	through DI dial switch, factory set PNP mode. 2) Impedance: 3.3 kΩ. 3) Input voltage range: 9 ~30V 4) HDI5 can be used as high-speed input port.
	DI4-COM	Digital input 4	
	HDI5-COM	Digital input 5	
Analog output	AO1-GND	Analog output 1	Voltage or current output is decided by dial switches CN2 and CN7. Output voltage range: 0–10 V Output current range: 0–20 mA
	AO2-GND	Analog output 2	
Digital output	Y1-COME	Digital output 1	Optical coupling isolation, dual polarity open collector output Output voltage range: 0–24 V Output current range: 0–50 mA Note that CME and COM are internally isolated, but they are short circuit externally when leaving factory (In this case Y1 is driven by +24 V by default). If you want to drive Y1 by external power supply, the external short circuit of CME and COM must be switched off.
Communication interface	485+,485-	Modbus Communication terminal	Modbus communication interface, it can choose the communication matched resistance through dial switch CN4.
Relay output 1	T/A-T/B	NC terminal	Contact driving capacity: AC 250V, 3 A, $\text{COS}\phi = 0.4$ DC 30V, 1A
	T/A-T/C	NO terminal	
Relay output 2	R/A-R/B	NC terminal	Contact driving capacity: 250 VAC, 3 A, $\text{COS}\phi = 0.4$ 30 VDC, 1 A
	R/A-R/C	NO terminal	
Keyboard extended line interface	CN6	External operation panel interface	External operation panel and parameter copy panel interface, take out the bidirectional crystal head, it can expand the standard network cable.

☞ Signal input terminals wiring instruction

1) AI analog input

Since the weak analog voltage signal is easy to suffer external interferences, it needs to employ shielded cable generally and the length shall be no longer than 20 meters, as shown in Fig. 3-10. In case the analog signal is subject to severe interference, and analog signal source side shall be installed with filter capacitor or ferrite magnetic core.

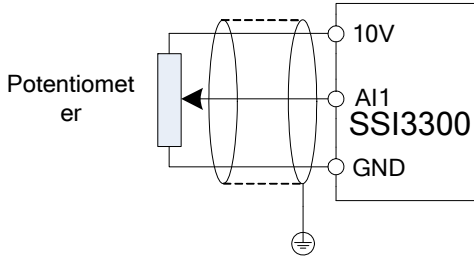

Fig.3-10 Schematic Diagram for Connection of Input Terminal of Analog Signal

2) Digital input terminal:

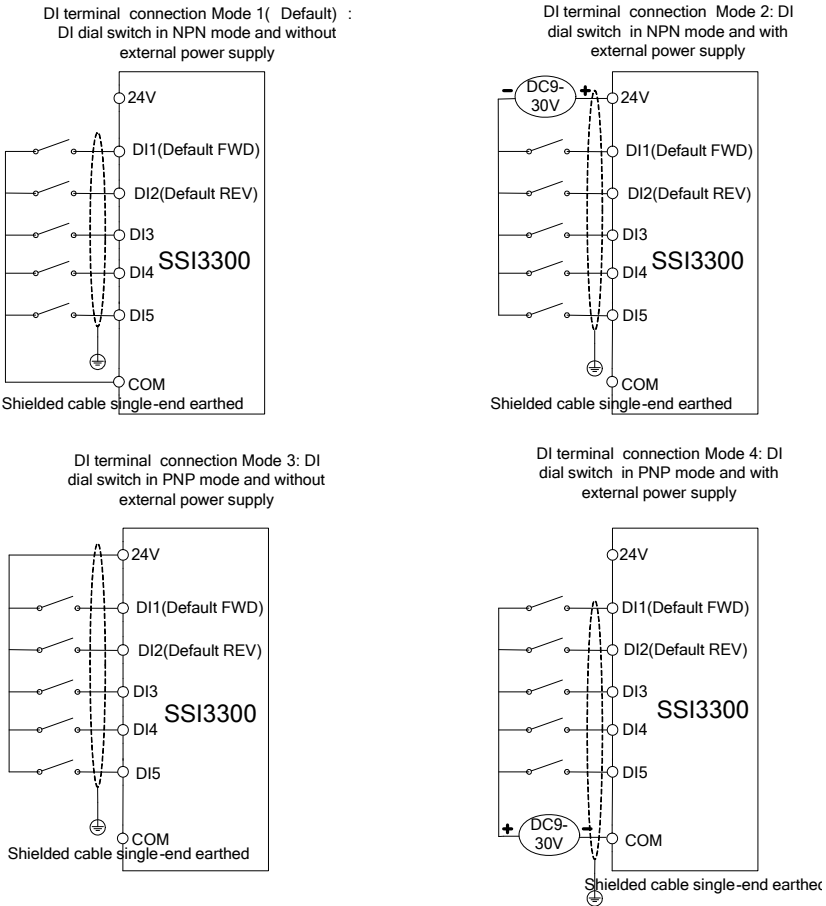

Fig 3-11 Four different wiring diagram

It needs to employ shielded cable generally, with cable length of no more than 20 meters. When active driving is adopted, necessary filtering measures shall be taken to prevent the

interference to the power supply. It is recommended to use the contact control mode.

3) Y1 Digital output terminal:

When the digital output terminal needs the drive relay, absorption diode shall be installed at the two sides of the relay coil and the drive capacity should be no more than 50mA. Otherwise it may easily damage DC 24 power supply.

Caution: The absorption diode shall be installed with correct polarity, as shown in Fig.3-12, otherwise, when it has output on the digital output terminal, the DC 24V power supply will be damaged immediately.

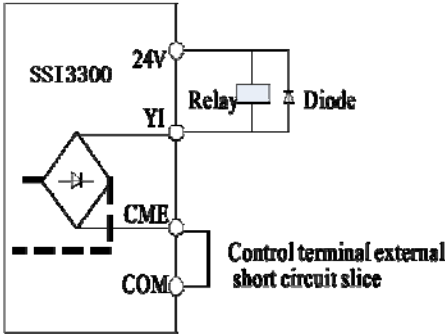

Internal Power Supply

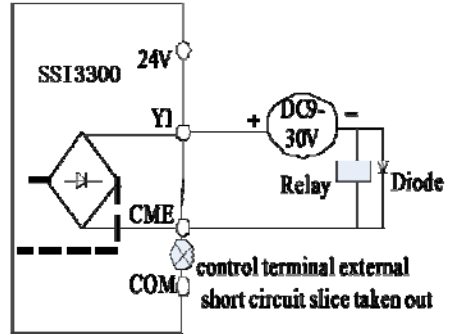

External Power Supply

Fig.3-12 Schematic diagram for digital output terminal Y1 wiring

Chapter 4 Operation and Display

4.1 Operation and Display Interface Introduction

We can change the function parameter, monitor the working status and control (start up/stop) the running inverter through the operation panel. The appearance and function are like below:

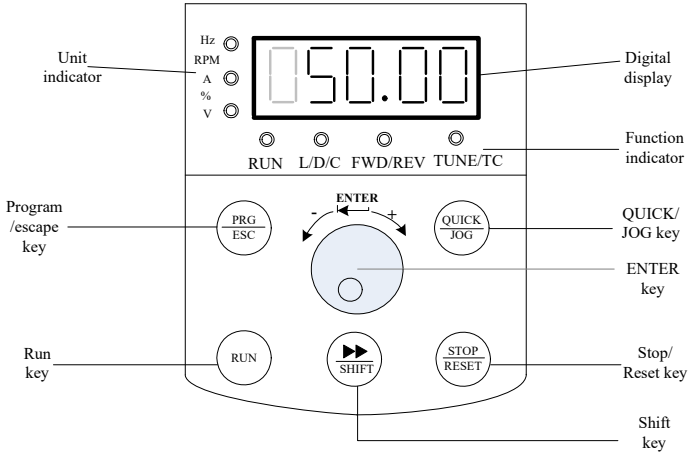

Fig.4-1 schematic diagram of operation panel 1 (standard LED keyboard 1)

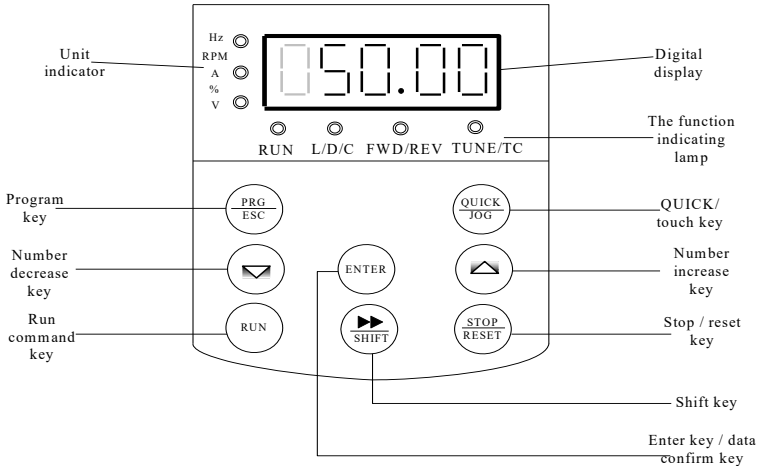

Fig.4-2 Schematic diagram of operation panel 2 (selective LED keyboard 2, declare in the order request if you need this panel)

Keyboard 1 and keyboard 2 switching operation mode: pressing the PRG key and the STOP key at the same time, don't release until "END" to appear, switching success.

4.1.1 Description of Function LED Indicator

LED Symbol		Unit	Implication	Color
Unit LED	Hz	Freq. Unit	LED on— current parameter is frequency value	Green
	A	Current Unit	LED on— current parameter is current value	Green
	V	Voltage Unit	LED on— current parameter is voltage value	Green
	RPM (Hz+A)	Speed Unit	LED on —current parameter is rotation speed value	Green
	% (Hz+V)	Percentage	LED on—current parameter is percentage value	Green
Function LED	RUN	running status LED	LED on—in the status of running Light off—in the status of stop LED flash—in the status of sleep	Green
	L/D/C	control mode LED	LED off—in the status of keyboard control mode LED on—in the status of terminal control mode LED flash—in the status of remote communication control mode	Red
	FWD/RE V	running direction LED	LED off—in the status of forward rotation LED on—in the status of reverse rotation LED flash—the target frequency is opposite to the actual frequency or in the status of reverse-run prohibition	Red
	TUNE/T C	tuning/torque /fault LED	LED on—in the status of torque control LED flash—tuning/fault	Red

4.1.2 LED display

Five digits LED is able to display setup frequency, output frequency, various monitoring data and alarm code. Function codes are usually displayed as decimal digits. For example, function code F0-11 is displayed as “50.00”, means decimal digit “50”. When the function codes are displayed as hexadecimal digits, the highest bit is “H.”, means present function code value is displayed in hexadecimal way. For example, when function code F7-29 is displayed as “H.003F”, the value of F7-29 is hexadecimal number”0x3f”

The user can freely set the monitoring data of stop and running status by the function code F7-29/F7-30, all the details are showed as function code F7-29/F7-30.

4.1.3. Keyboard instruction

Tab.4-1 keyboard function table

Key	Name	Function
PRG/ESC	Program/ Exit	entry or exit ,return to primary menu
	ENTER	entry into the menu interface ,confirm the setup parameters
	increase (+)	Increase in the data or function code
	decrease (-)	Decrease in the data or function code
»	shift key	Select the displayed parameters in turn on the stop display interface and running display interface, the specific content please refer to F7-29 and F7-30; when modifying parameters, select the modification digit of parameters
RUN	Run key	used in running operation under keyboard control mode
STOP/RESET	STOP/RESET	In the status of running, pressing it can stop the running operation; in fault alarm status, it can be used as reset. The characteristic of this key is limited by function code F7-02
QUICK/JOG	direction/jog run	When F7-28 is set as 0, it's used as jog run key. When F7-28 is set as 1, it's used as direction key, press this key now, the direction will be reversed.

4.2 Organization Way of the Inverter Function Code

The meaning of the function code group of SSI3300 as follows:

Function code group	Function description	Explanation
F0~FF	Basic function parameter group	Compatible with SSI3300 series of function code
H0~H3	2 nd motor parameter group	2 nd motor parameter, acceleration and deceleration time, control method, all can be set independently.
L0~L6	Enhancement function parameter group	System parameter set, custom-made user function code, optimization control, AI/AO revising, master-slave control, mechanical brake function and sleep function.
N0~NF	Professional inverter function selection group	Choose to use different professional inverter function
U0~U1	Monitoring parameter group	U0 is the fault record parameter group; U1 is the user monitoring parameter group, for the convenience to check the relevant output status.

4.3 Instruction of Function Code Viewing and Modification Methods

Function code parameter of SSI3300 inverter adopts three-level menu, it can view and monitor the parameter by operation panel. The three-level menu includes function parameter set (level 1 menu) →Function code (level 2 menu) →Function code setup value (level 3 menu). Refer to Fig.4-2 for the operation procedure. In the state parameter interface, it can check the different status parameter by the “》” key.

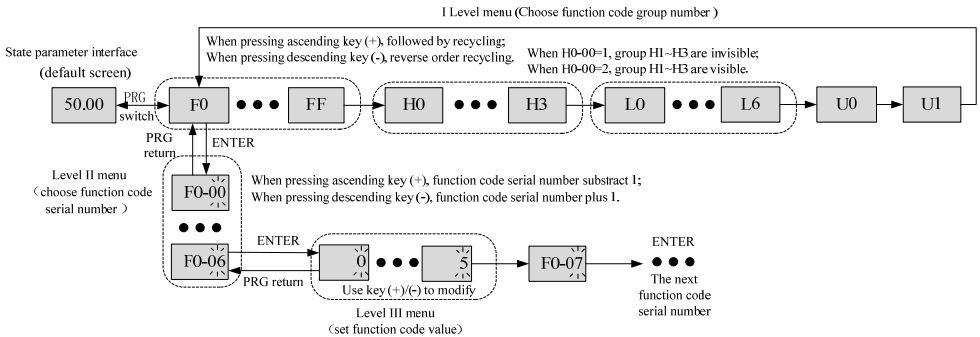

Fig.4-3 three-level menu operation flow chart

Tips: When operating with the three-level menu, you can press **PRG** or **ENTER** to return to the 2nd level menu. But it will save the present parameter data and move to the next function code if press **ENTER**, while it will give up the present parameter revising if press **PRG**.

For example: make function code F1-04 change from 0.00Hz to 5.00Hz.

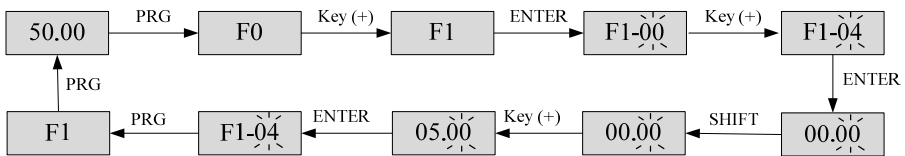

Fig.4-4 parameter setting operation flowchart

In the status of the 3rd menu, the value can't be modified if the parameter doesn't have the flashing digit. You can check the function code property description for the specific reasons.

4.4 Function Code Menu Mode and Switch Description

4.4.1 The definition and operation of multi-function shortcuts

The function of Quick/Jog can be defined by function code F7-28.

F7-28	Quick/Jog function selection		Default value	0	
	Setting range	0	Forward jog		
		1	Switch between forward and reverse		
		2	Reverse jog		
		3	Switch between panel control and remote control (terminal or communication)		

Quick/Jog is a multi-function key; it can set the function by this function code. It can switch both in stop and running status.

0: Forward jog

Achieve the forward jog function by the Quick/Jog key.

1: Switch between forward and reverse

Switch the frequency command direction by the Quick/Jog key, but it's effective only the instruction source in panel command channel.

2: Reverse jog

Achieve the reverse jog function by the Quick/Jog key.

3: Switch between panel control and remote control (terminal or communication)

Switch between present instruction source and keyboard control (local operation). It's ineffective if the present instruction source is keyboard control.

4.4.2 Function menu mode

For the convenience to check and operate, SSI3300 series of inverter provide three kinds of menu mode of function code to switch.

Menu mode	Description
-BASE Basic menu mode	Display the function code parameter in sequence, F0~FF, H0~H3, L0~L6, N0~NF, U0~U1, of which H1~H3 only displayed in the 2 nd motor. Display of N1~NF is relevant to the parameter setting of N0-00, not displayed by default.
-USER Customized parameter mode	Only display the customized function parameter (31 parameters at most). It can set freely by the group L1. Function code start with "U" and can modify the function code parameter value directly. It has defined 19 function codes which are frequently used before the delivery. Meanwhile, user can clear the custom-made function by L1-00, then redefine L1-01~L1-31.
-NOTF Default value modify parameter mode	When enter this mode, it only display the function codes which are different from the default parameter. The function codes are start with "N".

Tab.4-1 Group L1 default customized function code

Function code	Default value	Name	Function code	Default value	Name
L1-00	0	Clear the custom-made function	L1-10	uF4-05	Rated frequency of motor 1
L1-01	uF0-03	Control method	L1-11	uF4-06	Rated rotation speed of motor 1
L1-02	uF0-04	Instruction source	L1-12	uF4-12	Acceleration while in the dynamically complete tuning
L1-03	uF0-06	Main frequency source X selection	L1-13	uF4-13	Deceleration while in the dynamically complete tuning
L1-04	uF0-23	Accelerating time 1	L1-14	uF5-00	Function selection of terminal DI1
L1-05	uF0-24	Decelerating time 1	L1-15	uF5-01	Function selection of terminal DI2
L1-06	uF4-00	Tuning selection of motor 1	L1-16	uF5-02	Function selection of terminal DI3
L1-07	uF4-01	Rated power of motor 1	L1-17	uF6-00	Output selection of relay 1
L1-08	uF4-02	Rated voltage of motor 1	L1-18	uF6-01	Output selection of relay 2
L1-09	uF4-04	Rated current of motor 1	L1-19	uF6-02	Output selection of Y1

4.4.3 Switch of function menu mode

The inverter is in “-BASE” basic menu mode in default. If it’s needed to switch the menu mode, pressing “ENTER” for 3s on the state parameter interface. When it’s done it displays the present menu mode (-BASE\USER\NOTF) for 3s, then back to the state parameter interface. You can check and set the function code in present menu mode. The detail flowchart is as below.

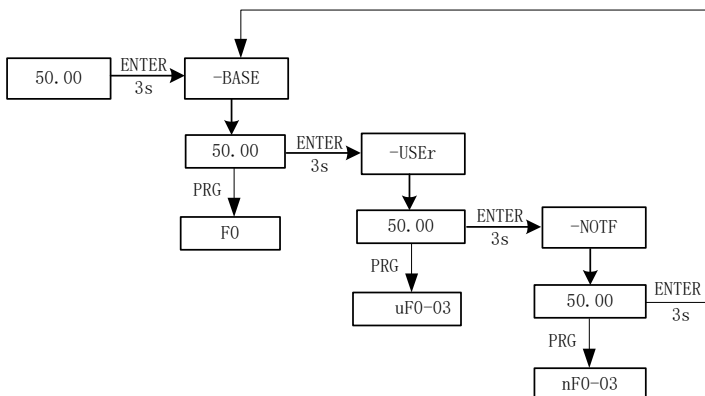

Fig.4-5 operation diagram of the menu mode switch

4.5 Preparation before Running

4.5.1 Customized function code setting

The customized menu has been saved in 19 frequently used parameters in default, showed as tab.4-1. The user can clear the customized function code by L1-00=1, and redefine function code by L1-00~L1-31. The switching among menu modes as described in section 4.4.3.

4.5.2 Procedures before running

The flowchart in this chapter has tell us the basic procedures before start the inverter, please choose the corresponding flowchart according to the accrual application. We only introduce the basic settings in this section.

Flow chart	Sub flowchart	Content	page
A	-	Basic steps from installation, wiring to running	55
-	A-1	Running under open-loop vector (speed sensor less vector) control	56
-	A-2	Running under V/F control	57

Flowchart A (connecting to the motor by the least setting change)

Flowchart A explains the connection to the motor by the least setting. The setting will have some differences for the different use. Please use the initial set parameter of the inverter in the application which doesn't need precise control.

Sub flowchart A-1 (motor running with open-loop vector control mode)

Sub flowchart A-1 explains the startup steps in open-loop vector control mode. It's more effective for vector control when high starting torque, torque limitation etc are needed.

Sub flowchart A-2 (simple motor running with V/F control mode)

When running with V/F control mode, please set the parameter according to below flowchart. It is more effective of V/F control in fan or pump application.

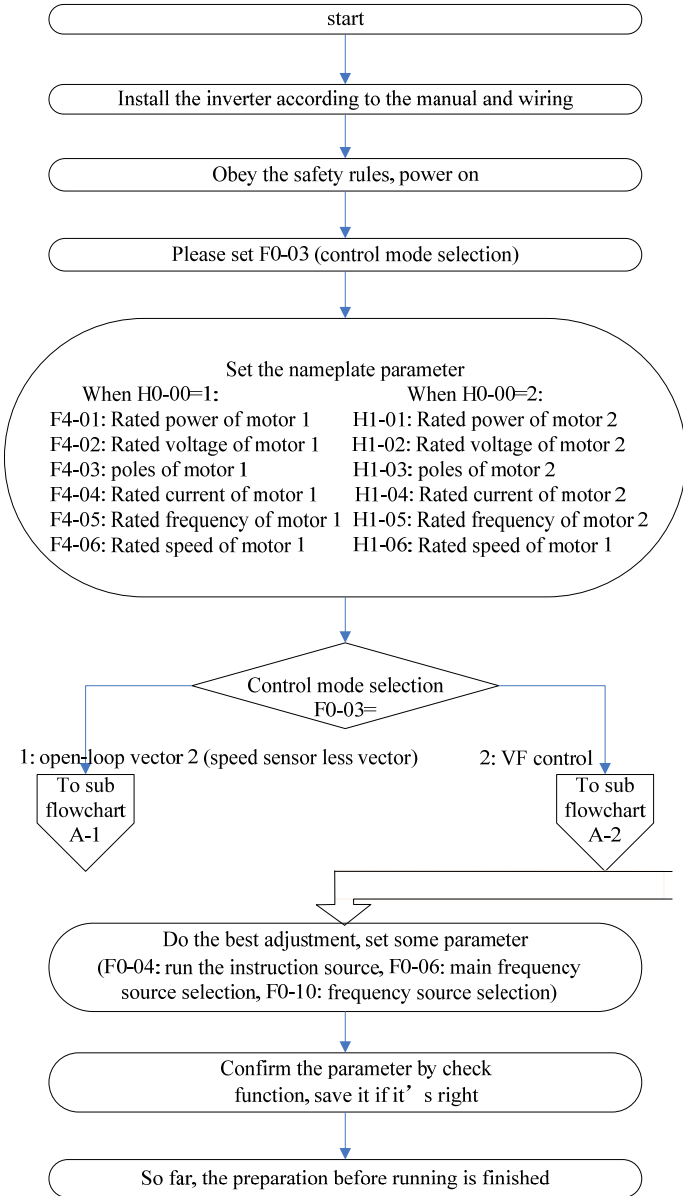

Figure 4-6 basic steps before running

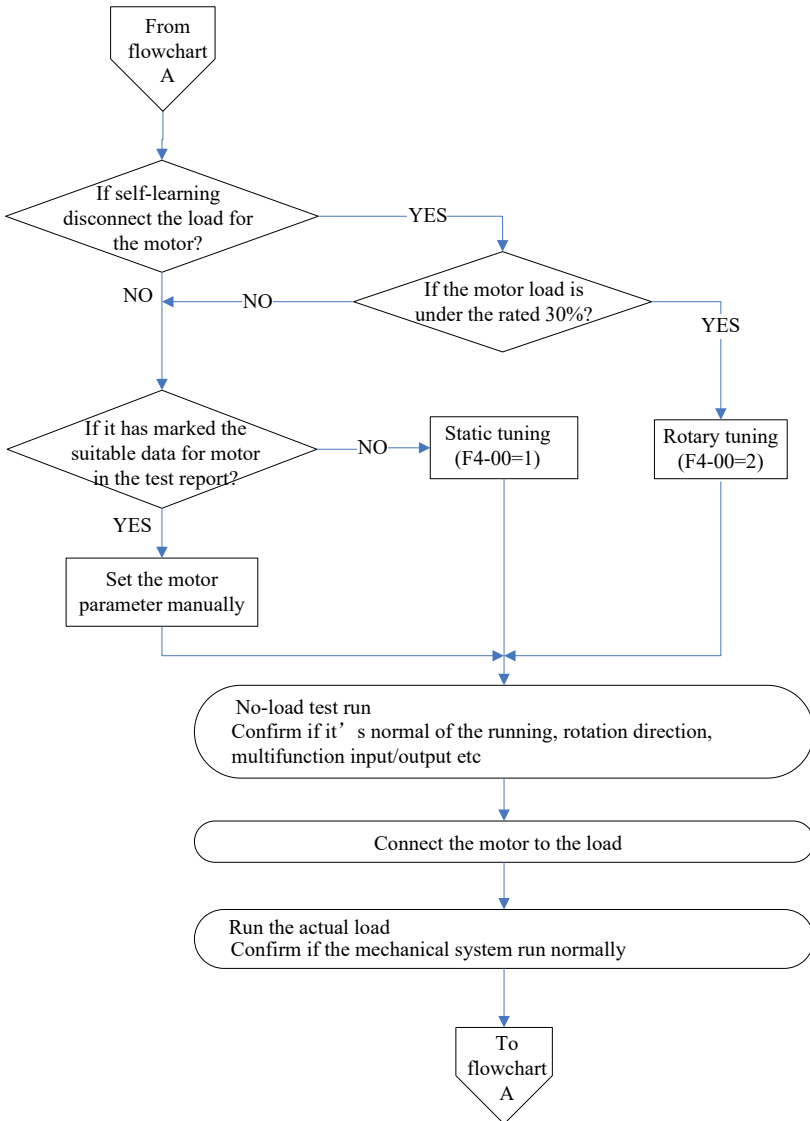

Fig.4-7 open-loop vector control running steps

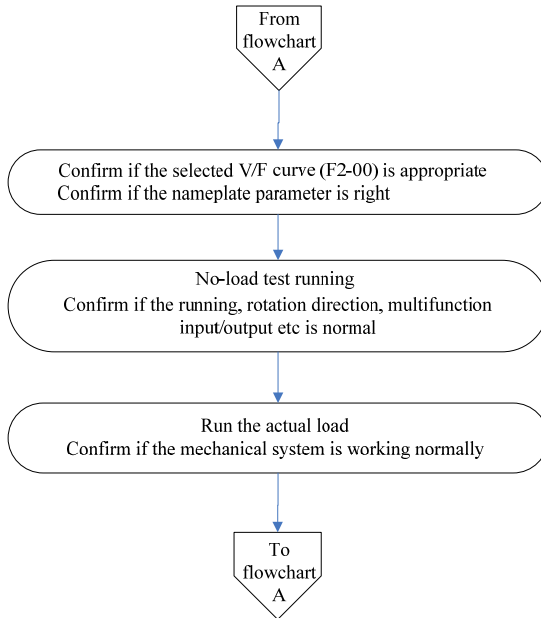

Fig.4-8 V/F control mode running steps

4.5.3 State parameter check

It can display various of state parameter through the key “»” either the machine is stopped or running. It’s function code F7-29 (running parameter) and F7-30 (stop parameter) choose the parameter display when it’s stop or running according to the binary bit. It has totally sixteen run/stop state parameter for choosing to display, more details please refer to the F7-29 and F7-30 description in chapter five.

4.6 Start-stop Control of the Inverter

4.6.1 Source selection of the start-stop signal

There are three source of the start-stop control command of the inverter, respectively are operate panel control, terminal control and communication control, you can choose it by function code F0-04.

F0-04	Set running command source		Default value	explanation
	Setting range	0	Operate panel command channel (LED off)	Press RUN, STOP to start-stop
1		Terminal command channel (LED on)	Define DI as the start-stop command terminal	
1		Communication command channel (LED flicker)	Use MODBUS-RTU protocol	

4.6.1.1 Operate panel start-stop control

When operate the panel to make the function code F0-4=0, it's panel star-stop control mode. Press the "Run" button then the inverter starts to run (LED on); press "STOP" button on the run status, then the inverter stops (LED off).

4.6.1.2 Terminal start-stop control

Terminal start-stop control is suited to use toggle switch or electromagnetic switch as start-stop occasions for the apply system, it also suited to this kind of electrical design which the controller use dry contact signal to control the inverter.

SSI3300 series of inverter provides several of terminal control ways, it can use function code F5-11 to confirm what control way does the terminal uses. Function code F5-00~F5-04 determine the input port of the start-stop control signal. For the specific setting ways, please refer to the detail explanation of function code F5-11, F5-00~F5-04 etc.

Example 1: It's require to use toggle switch as the start-stop switch of the inverter, connect the forward running switch signal to DI2 port, connect the reverse running switch signal to DI4 port. The way how to use and set is as follows:

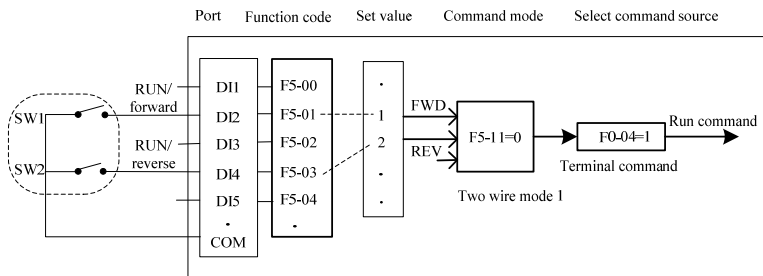

Fig.4-9 Illustration of terminal control start-stop mode

The control mode showed in the picture above: when SW1 is closed, the inverter runs in forward; when SW1 is open, the inverter is stopped. Similarly, when SW2 is closed, the inverter runs in reverse; when SW2 is open, the inverter is stopped. Whatever both SW1 and AW2 are closed or open, the inverter will be stopped.

Example 2: It's requiring to use electromagnetic pushbutton switch as the start-stop switch of the inverter, connect the start signal to DI2 port, connect the stop signal to DI4 port. The way how to use and set is as follows:

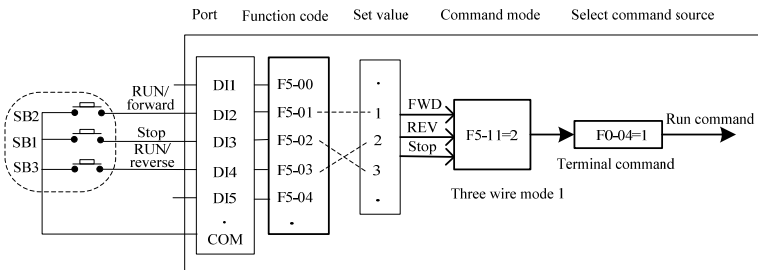

Fig.4-10 Illustration of terminal control start-stop mode

The control mode showed in the picture above: SB1 must keep closed on the normal running, otherwise the inverter will be stopped. The commands of SB2 and SB3 are effective when the buttons are pressed down. The running status of the inverter is determined by the final actions of these 3 buttons.

4.6.1.3 Communication start-stop control

The upper computer uses RS485 communication mode to control the inverter application. Choosing communication mode (F0-04=2) as control command source, then the start-stop of the inverter can be controlled by communication mode. The setting of the related function code is as follows:

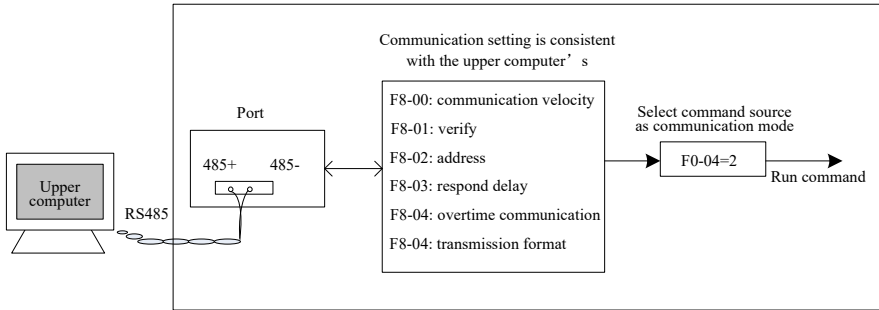

Fig.4-11 Illustration of communication control start-stop mode

In the above picture, if set communication overtime (F8-04) function code as nonzero value, the automotive stop function of the inverter overtime fault is active. It can avoid the inverter run out of control because of the communication fault or upper computer fault. This function can be use in some certain application.

The protocol which built in the communication port is MODBUS-RTU slave protocol, the upper machine must use MODBUS-RTU master protocol to communicate with it. For the related specific content of the communication protocol, please refer to the manual appendix A: SSI3300 Modbus communication protocol.

4.6.2 Start mode

There is 3 modes of the inverter, respectively are direct start, fast track start and asynchronous machine pre-excited magnetic start, it can be selected by function parameter F1-00.

When F1-00=0, it's the direct start mode which apply to the majority small inertia load. The frequency curve of the start procedure is as below picture. The "DC brake" function before start is suitable to the elevator and lifting load; "Start frequency" is suitable to the equipment drive which need start torque impact. For example the cement mixer equipment.

When F1-00=2, it's only suitable to asynchronous inductive motor load. Using pre-excited magnetism before start can improve the fast response feature of the asynchronous motor, and meet the application demand which requires short acceleration time. The frequency cure on the start procedure is as follows.

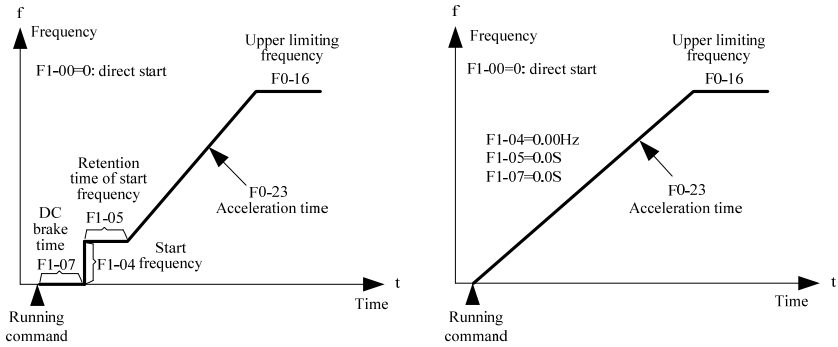

Fig.4-12 Direct start illustration

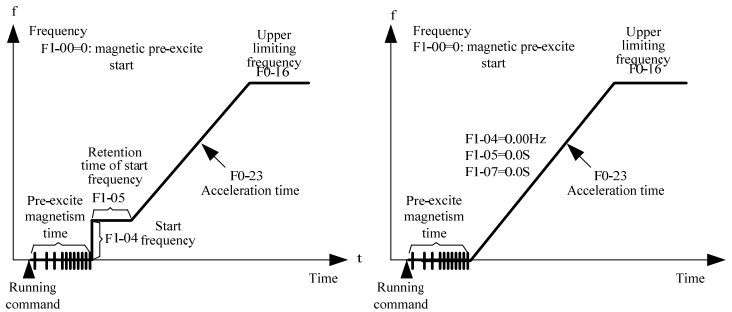
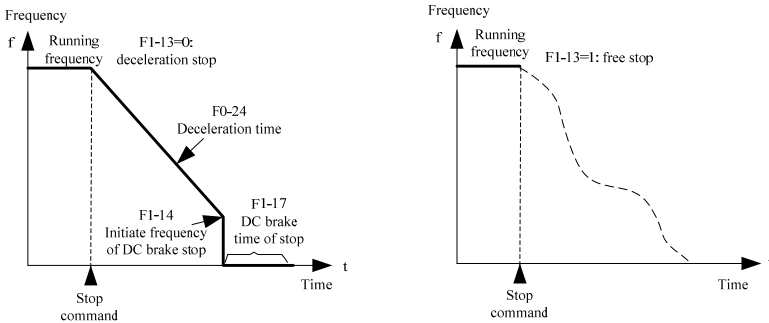

Fig.4-13 Pre-excited magnetism start illustration

4.6.3 Stop mode

There are 2 kinds of stop mode of inverter, respectively are deceleration stop and free stop. It can be selected by function code F1-13.



4.6.4 Jog running

In many occasions, the inverter need to run in slow speed so as to test the equipment or other function, so it's convenient to run in jog.

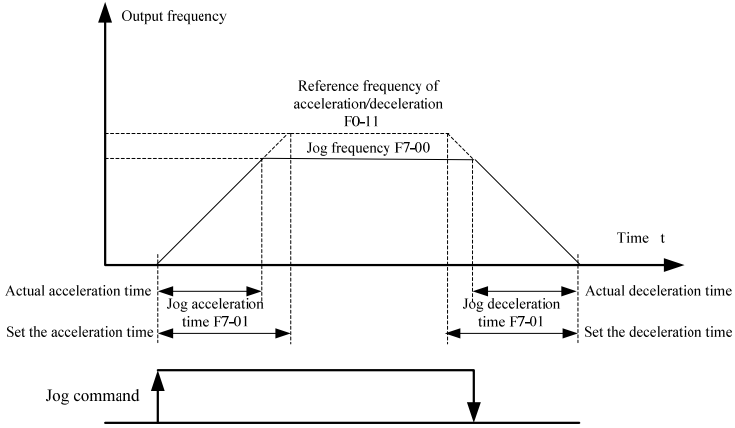

Fig.4-14 Illustration of Jog running

4.6.4.1 Setting the parameter and operating of the Jog by operation panel

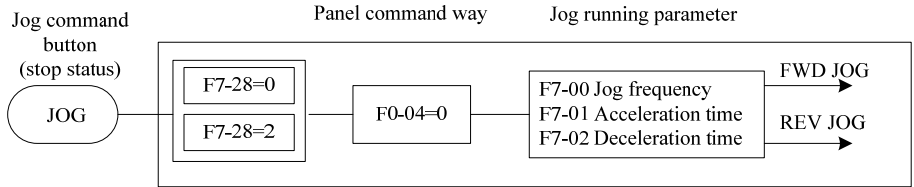

Fig.4-15 Illustration of jog parameter setting

After setting the related function code parameter as above picture, on the status of stop, pressing the JOG button, then the inverter starts to run in forward. when releasing the JOG button, the inverter decelerates to stop.

4.6.4.2 Setting the parameter and operating of the Jog by DI port.

In some production devices which need to use jog frequently, such as textile machine, it will be more convenient to use keys or buttons to control the jog. The related function code setting pls refer to below picture:

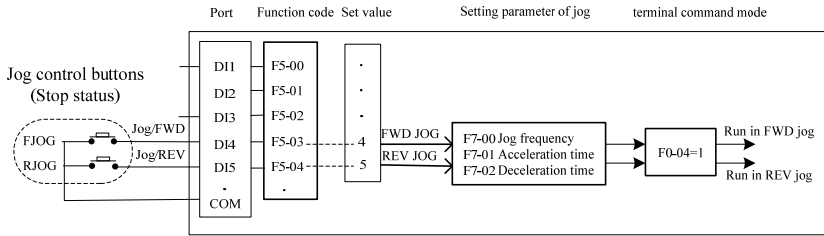

Fig.4-16 Parameter setting illustration of DI mode jog

After setting the related function code parameter as above picture, on the status of stop, pressing the FJOG button, then the inverter starts to run in forward. when releasing the FJOG button, the inverter decelerates to stop. Similarly, pressing the RJO button can operate on the inverter in reverse jog.

4.7 Running Frequency Control of the Inverter

The inverter has been set with 2 frequency preset channel, respectively named main frequency source X and auxiliary frequency source Y. They can work in single channel or switch at any time, even superimpose according to certain calculation method so as to meet the demand of different application occasions.

4.7.1 Select the main frequency source given

There are 9 kinds of main frequency source; they respectively are digital preset (UP/DN no memory after power-off), digital preset (memory after power-off), AI1, AI2, PULSE input, multi-segment command, simple PLC, PID, communication given etc. You can select the certain one by setting F0-06.

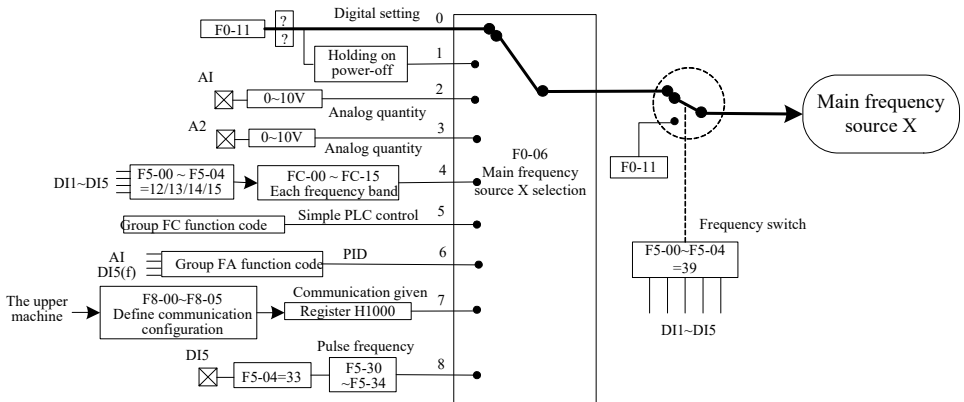

Fig.4-17 Illustration of main frequency source setting

From the different frequency source in the picture we can see that the running frequency of the inverter can be determined by function code, or by immediate manual adjustment, or by analog quantity, or by multi-speed terminal command, or by built-in PID controller to regulate closely through external feedback signal, and also can be determined by communication from upper

machine.

For every kinds of frequency source giving setting, the related function codes have been listed in the above picture, you can refer to the details of each function code when setting.

4.7.2 Usage of given with auxiliary frequency

The auxiliary frequency source Y comes in the same way as the main frequency source, and it's selected by F0-07.

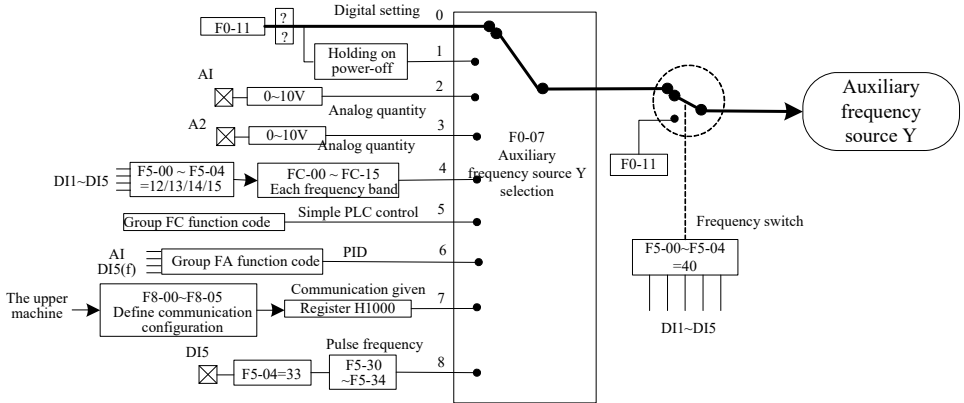

Fig.4-18 Illustration of auxiliary frequency source setting

In the actual operation, it's F0-10 that set the relationship between the target frequency and the main/auxiliary frequency source.

4.7.3 Frequency closed loop control of the process control

There is built-in PID adjuster in SSI3300, and it coordinate with how to choose the frequency given channel. Through it users can realize the automatic adjustment of the process control, for example constant temperature, constant pressure and tension etc application.

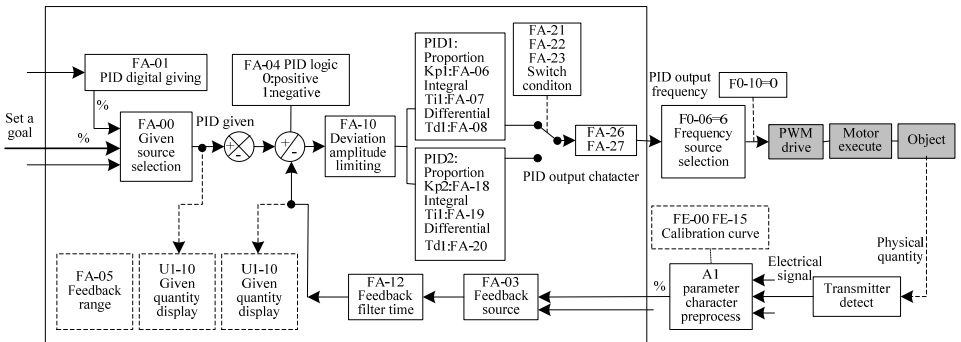

Fig.4-19 Illustration of frequency closed loop control

4.7.4 Swing frequency mode setting

In textile and chemical fiber process equipments, it can improve the uniformity of the winding spindle with swing frequency function like below picture by setting function code Fb-00~Fb-04, for more details please refer to the relevant function code description.

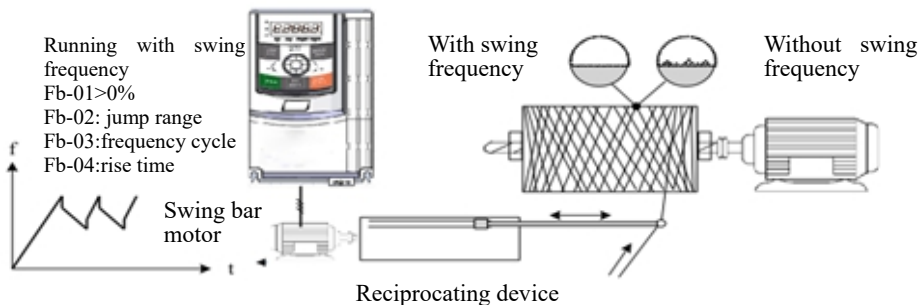

Fig.4-20 Illustration of swing frequency application setting

4.7.5 Multi-speed mode setting

For those application occasions where they don't need continuous adjustment of the running frequency and just need some certain frequency value, multi-speed control is suitable. SSI3300 can be set with at most 16 segments of running frequency, and select by 4 DI input signal combinations. Set the function codes of the DI port as function value 12~15, then the multi frequency commands input ports have been defined. The required multi frequency will be set by the multi frequency form of group FC, and set the "frequency source selection" as multi frequency giving like below picture:

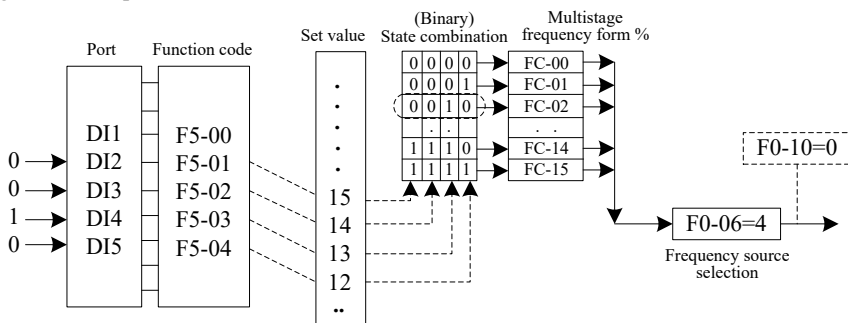

Fig.4-21 Illustration of multi-speed control mode

In the above picture, DI2, DI3, DI4 and DI5 are selected as signal input ports of the multi frequency, and successively compose 4 bytes of binary number, then combined to certain value according to the status, and select multi frequency at this time. When (DI5, DI4, DI3, DI2) = (0,0,1,0), the status combination number is 2, so it will pick the frequency value of function code FC-02 as target running frequency.

SSI3300 can set at most 4 DI ports as input ports of multi frequency command, and also allow less than 4 DI ports to give multi frequency. For the lacking digits, generally regard it as status 0.

4.7.6 Motor running direction setting

When press the button “RUN” after the inverter recovers to default parameter, the running direction of the drive is called forward. If the present rotating direction is opposite to the required direction, please set F0-13=1 or exchange any 2 wiring of the UVW output lines after cut off the electricity (Pay attention to wait the main capacitor of the inverter fully discharged) so as to exclude the direction problem.

In all the drive system, if only allow the system to run in forward direction but no reverse direction, it’s necessary to set F0-13=2. If there is reverse command at the moment, the inverter will decelerate to stop, and the FWD/REV light on the panel will flicker all the time. The logic relationship is like the picture below:

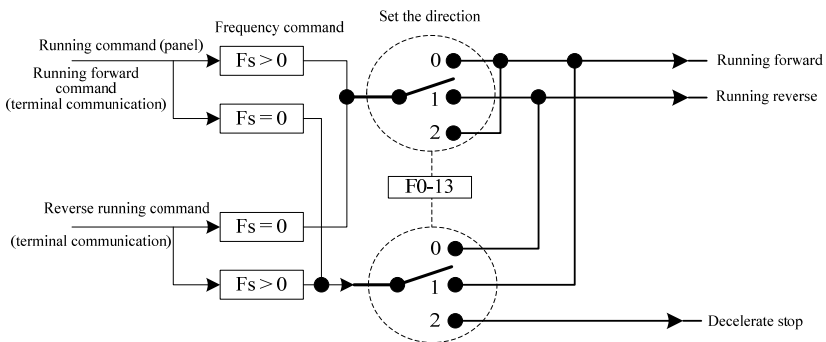

Fig.4-22 Illustration of motor running direction

For the application which is not allowed to have reverse rotation, please don’t modify the function code to change the running direction. Because when it restore to default, the function code mentioned above will also be reset. Thus the function can be realized by the NO.50 function of the digital input terminal DI.

4.7.7 Fixed-length control mode

SSI3300 has fixed-length control function. When the length pulse gets through DI (Choose 30 of DI function) terminal acquisition, make the pulse quantity of terminal sampling divide pulse quantity per meter (Fb-07), the calculated result is the actual length Fb-06. When the actual length is greater than the set length Fb-05, the multi-function digital switching value output “length reached” ON signal.

During the fixed-length process, it can reset the length (Choose 31 of DI function) through DI terminals. You can refer to below picture to set the device.

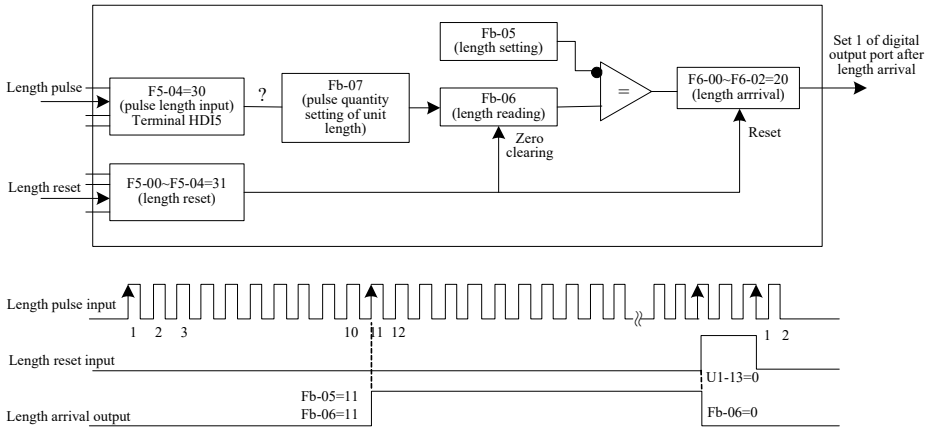

Fig.4-23 Function code setting of fixed-length control mode

- Attention:
- 1) It can't recognize the direction on the fixed-length control mode, so the length is calculated according to the pulse quantity.
 - 2) It can only use HDI as the "length count input" terminal.
 - 3) It can make it an automotive stop system to feed the length reached switching value output signal back to the stop input terminals of the inverter.

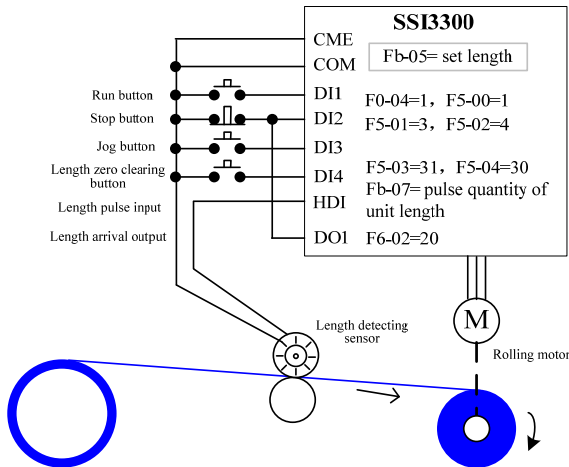

Fig. 4-24 Examples of fixed-length control function

4.7.8 Usage of count function of the inverter

Count value is collected by DI (Choose 28 of DI function) terminal. When the count value reaches the set count value Fb-08, multi-function digital switching value output “set count value reached” ON signal, then the counter stops counting.

When the count value reaches the set count value Fb-09, multi-function digital switching value output “specified count value reached” ON signal, the counter continue to counting at the moment until “set the count value” signal.

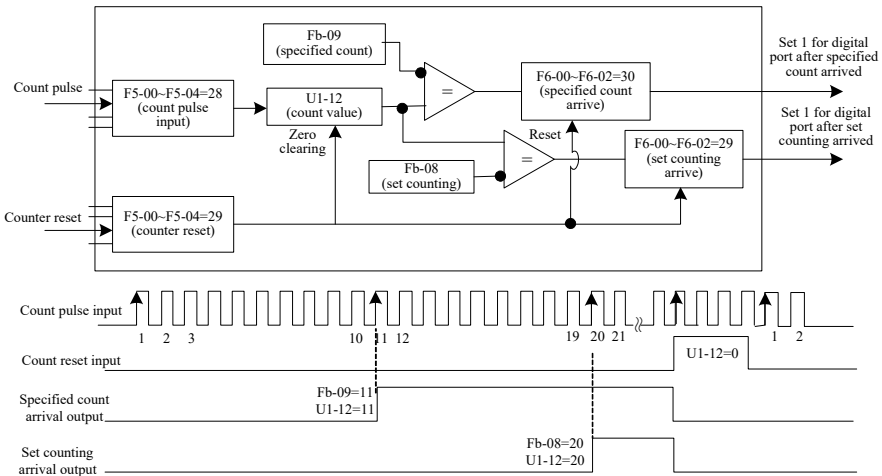

Fig.4-25 Counting mode function code setting

Attention:

- 1) Specified count value Fb-09 shouldn't be greater than set count value Fb-08.
- 2) It must use DI5 port when the pulse frequency is high.
- 3) The switch ports of “Set counting value reached” and “specified counting reached” can't be re-used.
- 4) On the status of RUN/STOP of the inverter, the counter will keep counting until the “set the count value” signal.
- 5) The count value can hold still on power-off.
- 6) It can make it an automotive stop system to feed the counting reached switching value output signal back to the stop input terminals of the inverter.

4.8 Motor Characteristic Parameter Setting and Automotive Tuning

4.8.1 Motor parameter that need setting

When the inverter is running with “vector control mode” (F0-03=1), it strongly dependent to precise motor parameter, thus this is one of the most important distinctions compared with “VF control” (F0-03) mode. The inverter must get the precise parameters from the controlled motor for the purpose to have good driving performance and running efficiency.

The required parameters are as below (function code of default motor 1):

Parameter of motor 1	Parameter description	mark
F4-01~F4-06	Rated power/ voltage/ current/ frequency/ revolving speed	Machine type parameter, manual input
F4-07~F4-11	The internal equivalent stator resistance/ inductive reactance/ rotor inductance	Tuning parameter

4.8.2 Automatic tuning and identification of motor parameters

The way for inverter to get the internal electrical parameters of the controlled motor include: dynamic identification, static identification, manual input the parameters and so on.

Identification methods	Adapted conditions	Effect
Dynamic identification without load	Synchronous motor and asynchronous motor: occasions where it's convenient for motor to separate from the application system.	Best
Dynamic identification with load	Synchronous motor and asynchronous motor: occasions where it's inconvenient for motor to separate from the application system.	Good
Static identification	Only for asynchronous motor: occasions where it's difficult for motor to separate from the load and dynamic identification is prohibited.	Worse
Input parameters	Only for asynchronous motor: occasions where it's inconvenient for motor to separate from the application system. Copy the parameter from the motor which is the same type as the target motor and has been identified by the inverter, then input it to the function code F4-01~F4-11.	Good

The automatic tuning process of the motor parameters is as below:

Below we take the default motor 1 as example to explain the parameter identification methods, and it's in the same way as motor 2.

Step 1: if the motor can be separate from the load, take the motor away from the load part on power-off condition, and let the motor run freely on empty load.

Step 2: After power-on, make the command source (F0-04) of the inverter as the command channel of the operation panel.

Step 3: Input the parameters according to the nameplate (F4-01~F4-06), then input the actual parameters according to below table (Choosing according to the present motor):

Motor selection	Parameters
Motor 1	F4-01: The rated power F4-02: The rated voltage F4-04: The rated current F4-05: The rated frequency F4-06: The rated revolving speed
Motor 2	H1-01~H1-06: Same definition as above codes

Step 4: if it's asynchronous motor, please choose 2 (Completely dynamic tuning) of F4-00 (Tuning choice, using H1-00 for motor 2), then press button ENTER, then the keyboard displays as below:



Then press button RUN, the inverter will drive the motor to accelerate/decelerate, forward/reverse run, and to turn on the indicator light. The whole identification will keep running for about 2 minutes. The tuning is finished when the above signals disappear and back to normal display status. The inverter will figure out below parameters of the motor after the tuning.

Motor selection	Parameters
Motor 1	F4-07: No-load current of motor 1 F4-08: Stator current of motor 1 F4-09: Rotor resistance of motor 1 F4-10: interaction inductive reactance F4-11: leakage inductive reactance of motor 1
Motor 2	H1-07~H1-11: same definition as above

If the motor can't completely separate from the load, please choose 1 (static tuning) of F4-00 (using H1-00 for motor 2), then press RUN button on the panel, so the parameter identification starts.

4.8.3 Setting and switching of multi-group motor parameters

It can be assigned by function code H0-00 or digital input terminal function 41 to choose present valid parameter groups. But it has privilege when digital input terminal function 41 is effective, so H0-00 setting is invalid.

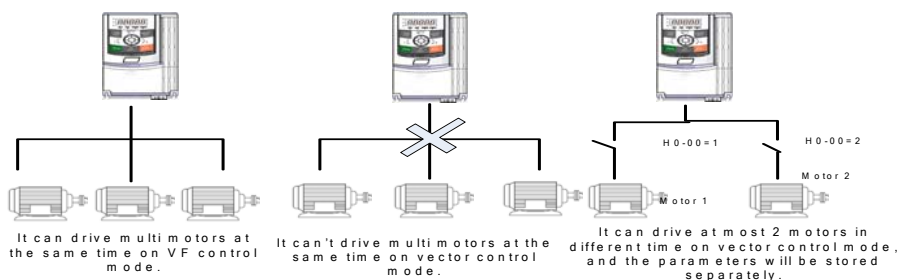

Fig.4-26 Switching of multi-group motors

4.9 Usage of Inverter DI Ports

The control board comes with 5 DI ports, numbering as DI1~DI5. The internal hardware of DI port has 24Vdc power source for testing use, so users just need to short connect the DI port and the COM port, the DI signal can be put into the inverter.

On the default status, F5-13=00000, it's valid signal (logic 1) with DI port short connected. The DI is invalid (logic 0) signal when DI port is hanging. Users can also change the valid mode:

The signal is invalid when the DI ports are short connected (logic 0) while the signal is valid (logic 1) when the DI ports are hanging. It needed to modify the place which is corresponding to F5-13 to 1. The two function code corresponds to the valid setting of DI1~DI5.

The inverter has set software filter time (F5-10) for the input signal of DI port for the purpose to improve the anti-interference ability. For DI1~DI 3 input terminals, it has specially provide signal delay function for some application in need.

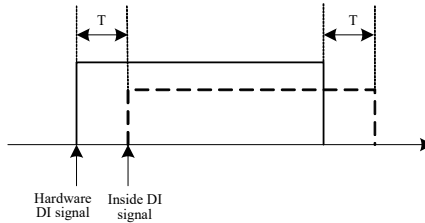

Fig.4-27 DI delay setting

The above-mentioned function of 5 DI ports can be defined in F5-00~F5-04 function code. Each DI can be selected from 53 functions according to the demand.

For the design of hardware characteristic, only HDI can accept high frequency pulse signal. So for the application that need high speed counting, please arrange it to HDI port.

4.10 Usage of Inverter DO Ports

The control board comes with 3 lines of digital output, respectively are control board RELAY 1, RELAY 2 and Y1, of which Y1 is transistor type output and can drive 24Vdc low voltage signal loop; relay output can drive 50 V ac control loop.

It can define each digital output function by setting the value of parameter F6-00 ~ F6-02. It can indicate every kinds of working status or warning signals of the inverter, totally about 45 function setting, with which can meet the demand of users for certain automatic control requirements. For the specific setting value please refer to detail description of group F6 function code.

4.11 AI Input Signal Character and Pretreatment

The inverter can support 2 lines of AI source.

Ports	Input signal characteristics
AI1-GND	Can receive 0~10Vdc signal
AI2-GND	When the dial switch “AI2 I-U” is in “U” mark position, it can receive 0~10Vdc signal; when the dial switch “AI2 I-U” is in “I” mark position, it can receive 0~20mA current signal.

AI can be used when the inverter uses external voltage current signal as frequency source given, torque given, voltage given when VF separates, PID given or feedback.

The sampling value of AI port can be read in function code U1-08 and U1-09, the calculated value can be provided for internal later calculations, so users can’t read it directly.

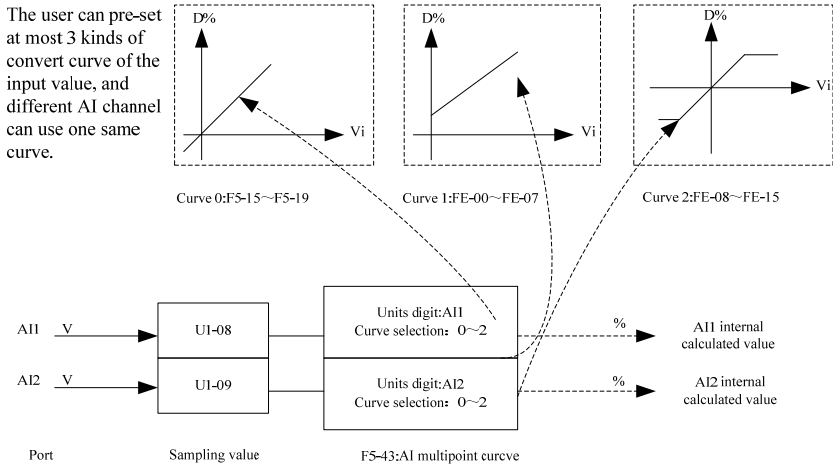

Fig.4-28 The actual given of AI signal

4.12 Usage of Inverter AO port

The inverter totally support 2 lines of AO output.

Ports	Input signal characteristics
AO1-GND	When the dial switch “AO1 I-U” is in “U” mark position, it can receive 0~10Vdc signal;
	when the dial switch “AO1 I-U” is in “I” mark position, it can receive 0~20mA current signal;
AO2-GND	When the dial switch “AO2 I-U” is in “U” mark position, it can receive 0~10Vdc signal;
	when the dial switch “AO2 I-U” is in “I” mark position, it can receive 0~20mA current signal;

AO1 and AO2 can be used in analog to indicate the internal running parameters. The indicated parameter attribute can be chosen by function code F6-09 and F6-10.

Before the indicated parameter output, it can also be revised as showed in below picture the oblique line. For the details of function code F6-13~F6-16 please refer to chapter 5.

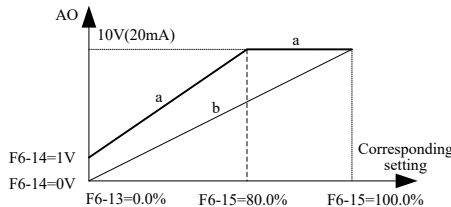

Fig.4-29 AO output illustration

4.13 Usage of Inverter Serial Communication

For hardware communication parameter configuration of communication ports please refer to group F8 function. It's the premise of normal communication to set the communication velocity and data format in accordance with the upper computer.

The serial ports of SSI3300 have built in MODBUS-RTU slave communication protocol, so the upper computer can check or revise function code, various of status parameters, send running command and running frequency to the inverter through the serial ports.

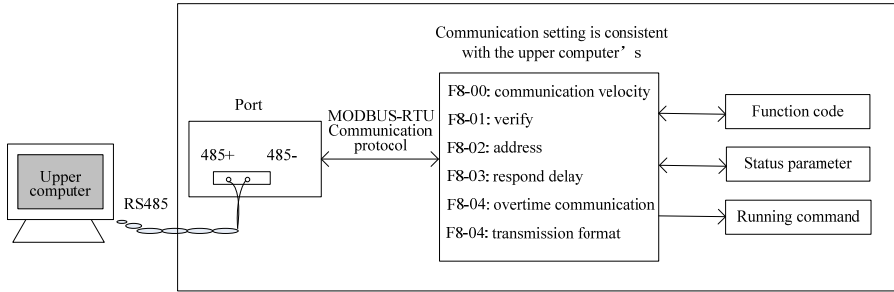

Fig.4-30 communication setting illustration

The function code, various of status parameters and command information in internal of SSI3300 are organized by “register parameter address”, so the master machine can define the protocol of communication data interaction. For details please refer to appendix A: SSI3300 Modbus communication protocol.

4.14 Password Setting

The inverter provides password protection function. It's just the user password when setting F7-49 to nonzero status. The password protection is effective after it's back to state parameter interface. Pressing button PRG, it will display “-----”, just showing the state parameter. If it's need to enter the normal menu to check and set the function code, you must press buttons on “-----” interface until it displays “00000” on the panel and then input the right password.

If you want to cancel the password protection function, you get through it with the right password, then set F70-49 to zero.

Chapter 5 Parameter Description

5.1 Group F0 Basic Function

F0-00	Product model	Range: 0.00~655.35	Default: 53#.##
-------	---------------	--------------------	-----------------

This parameter is provided only for the user to view the software version and cannot be modified.

F0-01	G/P type display	Range: 0~1	Default: model dependent
-------	------------------	------------	--------------------------

This parameter is provided only for the user to view the model and cannot be modified

0: applied to the constant torque of the designated rated parameters(G type).

1: applied to the variable torque loads(fan and pump loads) of the designated rated parameters(P type).

F0-02	Rated current	Range: 0.1A to 3000.0A	Default: model dependent
-------	---------------	------------------------	--------------------------

This parameter is provided only for the user to view the rated current and cannot be modified.

F0-03	Control mode	Range: 1~2	Default: 2
-------	--------------	------------	------------

1:open loop vector control (speed sensorless vector control)

2:V/F control

F0-04	Running command source selection	Range:0~2	Default: 0
-------	----------------------------------	-----------	------------

Select control command channel for inverter.

The inverter control command includes start, stop, forward rotation, reverse rotation and Jog.

0:operation panel command channel (LED OFF);

Perform running command control with key on the operation panel such as RUN,STOP/RES.

1:Terminal command channel (LED ON)

Perform running command control by the multifunctional input terminals, such as FWD, REV, JOGF, JOGR etc.

2:Serial port command channel (LED flashes)

The running command is sent by the host computer via communication mode.

F0-05	Base frequency for modification during running	Range:0~1	Default: 0
-------	--	-----------	------------

0: Running frequency.

1: Set frequency.

This parameter is effective only when the frequency source is digital setting, and it's used to confirm if the action of button Up/Down or terminal Up/Down is revising the setting frequency or running frequency. The biggest difference is reflected in the acceleration process.

F0-06	Main frequency source X selection	Range:0~8	Default: 1
-------	-----------------------------------	-----------	------------

Select the input channel for main reference frequency of the inverter. There are 9 types of main given frequency channels:

0: Up/Down modify frequency, non-record on stop.

The initial value is the value of FO-11 “Digital Setup Present Frequency”.

It can change the setup frequency value of the inverter through the key ▲ and ▼ on the keyboard (or UP and DOWN of multifunction input terminals). Stop-recording on downtime means the changed frequency value can't be recorded after the stop of the inverter. Then the setting frequency value will recover to the value of FO-11 “Digital Setup Present Frequency”.

1: Up/Down modify frequency, recording on power-off.

The initial value is the value of FO-11 “Digital Setup Present Frequency”.

It can change the setup frequency value of the inverter through the key ▲ and ▼ on the keyboard (or UP and DOWN of multifunction input terminals).

Recording on power-off means that the setting frequency upon restart of inverter remains the same as the value before power-off.

2: AI1

3: AI2

It means that the frequency is determined by the analog input terminal, SSI3300 Driver offers two analog input terminals, that is AI1 and AI2, and AI1 is the voltage input from 0V to 10V, the other is the current input from 4mA to 20mA. All of them can be selected by the dial switch on the control board.

The corresponding relationship curves of the input voltage of AI1, AI2 and the target frequency can be selected by F5-45. SSI3300 provides 4 groups of relationship curves, of which 2 groups of them are straight lines (2 points correspondence) and the other 2 groups are arbitrary curves (2 points correspondence). Users can set them through function code F5-15~F5-24 and group FE function code. Function code F5-45 can be used to set these 2 analog input (AI1~AI2), respectively to choose one of the 4 groups of curves.

When AI is as given frequency, voltage/ current input correspond to 100.0%, means the percentage of the maximum output frequency FO-14.

4. Multi speed

Select multi speed running mode in need of setting Group F5 “Input Terminal” and Group FC “Multi speed and PLC parameters” to determine the relative relationship between the reference signal and the reference frequency.

5. Simple PLC

Select the simple PLC mode in need of setting to Group FC “MS speed and “PLC” parameter to determine the reference frequency when the frequency source is simple PLC.

6. PID

Select the process PID control. In the meantime, it needs to set Group FA “PID Function” .The running frequency of the inverter is that after PID functions. Regarding PID reference source, reference quantity and feedback source please check the Group FA “PID Function”.

7. Communication reference

It means that the main frequency source is given by the host computer via communication mode (details refers to Appendix A SSI3300 MODBUS communication protocol).

8. Pulse frequency reference

Pulse frequency reference is input by HDI port of the panel, and the pulse slope can be set by

F5-30~F5-34.

F0-07	Auxiliary frequency source Y selection	Range:0~8	Default: 0
-------	--	-----------	------------

When the auxiliary frequency source is used as independent frequency reference channel, it is used in the same way as the main frequency source X

when the auxiliary frequency source is used as superposition reference (unit's digit of F0-10 is 1, 2, 3, 4), special points as follows:

1. When the auxiliary frequency source is the digital reference, the present frequency (F0-11) is ineffective. It can adjust the main reference frequency through the key ▲ and ▼ on the keyboard (or UP and DOWN of multifunction input terminals)

2. When the auxiliary frequency source is the analog input reference (A11, A12) 100% of input setup is relative to the auxiliary frequency source range (refer to F0-08-F0-09). In need to adjust the main reference frequency, please set the corresponding setup range of analog input to “-n% to +n%” (refer to F5-15 and F5-24).

Tips: there is difference between the auxiliary frequency source Y selection and the main frequency source X set up value, that is to say, the main and auxiliary frequency sources cannot use the same frequency reference channel.

F0-08	Range of auxiliary frequency Y selection	Range:0~1	Default: 0
-------	--	-----------	------------

0: Relative to maximum frequency.

1: Relative to main frequency X.

F0-08 is used to determine the relative object of the range, if it's relative to the maximum frequency (F0-14), the range is fixed value. If it's relative to main frequency source X, the range will change with the main frequency source X.

F0-09	Range of auxiliary frequency Y	Range:0%~100%	Default: 100%
-------	--------------------------------	---------------	---------------

When the frequency source choose to use frequency superposition giving (setting refer to F0-10), it's used to determine the adjusting range of the auxiliary frequency source.

F0-10	Frequency source superposition selection	Unit's digit:0~4 Ten's digit:0~3	Default: 0
-------	--	-------------------------------------	------------

This parameter is used to select the frequency giving channel. Frequency reference is realized through combination of the main frequency source X and the auxiliary frequency source Y.

Unit's digit: Frequency source selection

0: Main frequency source X.

Main frequency X is as the target frequency.

1: X and Y operation result.

X and Y operation result is the target frequency, and the operation relations refers to the description of “ten's digit”.

2: Switchover between X and Y (by DI terminal).

When the multi-function input terminal function 18 (frequency switch) is invalid, the main frequency X is the target frequency.

When the multi-function input terminal function 18 (frequency switch) is valid, the auxiliary frequency Y is the target frequency.

3: Switchover between X and “X and Y operation” (by DI terminal).

When the multi-function input terminal function 18 (frequency switch) is invalid, the main frequency X is the target frequency.

When the multi-function input terminal function 18 (frequency switch) is valid, the superposition result frequency X is the target frequency.

4: Switchover between Y and “X and Y operation” (by DI terminal).

When the multi-function input terminal function 18 (frequency switch) is invalid, the main frequency X is the target frequency.

When the multi-function input terminal function 18 (frequency switch) is valid, the superposition result frequency Y is the target frequency.

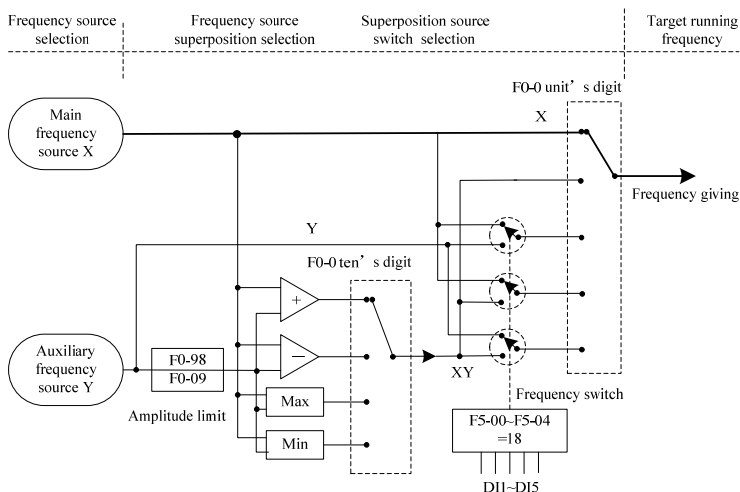

Fig.5-1 Illustration of frequency source superposition

Ten's digit: frequency source operation relations

0: Main frequency source X+ Auxiliary frequency source Y

The sum of main frequency source X and auxiliary frequency source Y is the target frequency, so it realizes the frequency superposition giving function.

1: Main frequency source X- Auxiliary frequency source Y

The difference of main frequency source X and auxiliary frequency source Y is the target frequency.

2: Max(X,Y)

Use the maximum value between main frequency source X and auxiliary frequency source

Y as the target frequency.

3: $\text{Min}(X, Y)$

Use the minimum value between main frequency source X and auxiliary frequency source Y as the target frequency.

F0-11	Preset frequency	Range:0.00Hz~F0-14	Default:50.00Hz
-------	------------------	--------------------	-----------------

When the main frequency source is selected as “Digital setup” or “Terminal UP/DOWN”, this function code is the initial value of frequency digital setup of the inverter.

F0-13	Rotation direction selection	Range:0~2	Default:0
-------	------------------------------	-----------	-----------

0: Same direction: same direction with the current running direction of the motor.

1: Reverse direction: opposite direction with the current running direction of the motor.

2: Reverse forbidden: the inverter will decelerate to stop when it comes with reverse command.

Through modifying this function code, it can change the rotary direction of the motor without changing any other parameters, and the function is equivalent to change the rotary direction by adjusting any two lines of the motor (U, V, W).

Tips: After parameter initialization, the motor running direction will restore to the original status, so this action shall be carefully performed in the application where the rotary direction of the motor is not allowed to change after system debugging.

F0-14	Maximum output frequency	Range: 50.00Hz~600.00Hz<1>	Default: 50.00Hz
-------	--------------------------	----------------------------	------------------

<1> represent the frequency range when F0-20=2, and the range when F0-20=1 is 50.0Hz~1200.0 Hz.

F0-15	Frequency source upper limit	Range:0~4	Default:0
-------	------------------------------	-----------	-----------

This function code is used to define the source of upper limiting frequency.

0: Set by F0-16

1: AI1: 100% input setting corresponding to F0-14.

2: AI2: 100% input setting corresponding to F0-14.

3: Communication setting: the host machine giving through communication (details refer to Appendix A SSI3300 MODBUS communication protocol).

4: Pulse setting: pulse giving slope can be set by F5-30~F5-34.

In order to avoid galloping caused by material broken, it's better to set upper limiting frequency by analog. When the inverter is running to the upper limiting frequency, torque control is invalid and it continue to running with upper limiting frequency.

F0-16	Frequency upper limit	Range: F0-18~ F0-14	Default: 50.00Hz
F0-17	Frequency upper limit offset	Range: 0.00 Hz ~ F0-14	Default: 0.00Hz

When the frequency upper limit is analog value reference, this parameter is used as analog value offset, its reference value is F0-14. The addition of offset frequency and analog setup value of frequency upper limit are used as the final setup value of frequency upper limit.

F0-18	Frequency lower limit	Range: 0.00 Hz ~ F0-16	Default: 0.00Hz
-------	-----------------------	------------------------	-----------------

The inverter starts from the start frequency. If the giving frequency is lower than frequency lower limit in the running process, the inverter will keep running under frequency lower limit until it stops or the giving frequency is higher than the frequency lower limit.

F0-19	Command source binding select	Range: 000~ 888	Default: 000
-------	-------------------------------	-----------------	--------------

It's convenient for frequency source switching with 3 kinds of defined running commands and banding groups with 9 kinds of given frequency channels.

0: No Binding

1: Digital setting

2: AI1

3: AI2

4: Multi-speed

5: Simple PLC

6: PID

7: Communication setting

8: Pulse setting (HDI5)

Unit's digit: Binding operation keypad command to frequency source

Ten's digit: Binding operation terminal command to frequency source

Hundred's digit: Binding operation communication command to frequency source

Thousand's digit: Reserved

The meaning of above giving channels is same as main frequency X which choose F0-06. Please refer to F0-06 function description.

Different running command channels can bind the same frequency giving channels. When command source has bound frequency source, during the period that the command source is valid, frequency source set by F0-06~F0-10 will not work.

F0-20	Frequency fractional selection	Range: 1~ 2	Default: 2
-------	--------------------------------	-------------	------------

This parameter is used to confirm all the resolution of the function codes which are relevant to frequency.

1: One digit after the decimal point (0.1Hz).

2: Two digits after the decimal point (0.01Hz).

F0-21	Acceleration/Deceleration time unit	Range: 0~ 2	Default: 1
-------	-------------------------------------	-------------	------------

For the purpose to meet every kinds of demand, SSI3300 can provide 3 kinds of decelerating time unit, respectively are 1 second, 0.1 second and 0.01 second.

0: 1s

1: 0.1s

2: 0.01s

Attention: When modifying this function parameter, the decimal places display of the 4 groups of accelerating/ decelerating time will change and the corresponding accelerating/ decelerating time will also change. So be careful about it.

F0-22	Acceleration/Deceleration time base frequency	Range: 0~2	Default: 0
-------	---	------------	------------

This parameter is used to define the reference frequency of the accelerating/ decelerating time, you can see from fig.5-2 of its implication.

- 0: Maximum frequency (F0-14)
- 1: Set frequency
- 2: Rated motor frequency

F0-23	Acceleration time 1	Range: 0.0s~3000.0s<1>	Default: 10.0s
F0-24	Deceleration time 1	Range: 0.0s~3000.0s<1>	Default: 10.0s

<1> represent the range of acceleration time unit F0-21. When F0-21=0, the value is 0s~30000s; when F0-21=2, the value is 0.00s~300.00s.

Acceleration time of inverter means the required time from zero frequency to base frequency of acceleration/ deceleration (determined by F0-22) like t1 in fig.5-2.

Deceleration time of inverter means the required time from base frequency of acceleration/ deceleration (determined by F0-22) to zero frequency like t2 in fig.5-2.

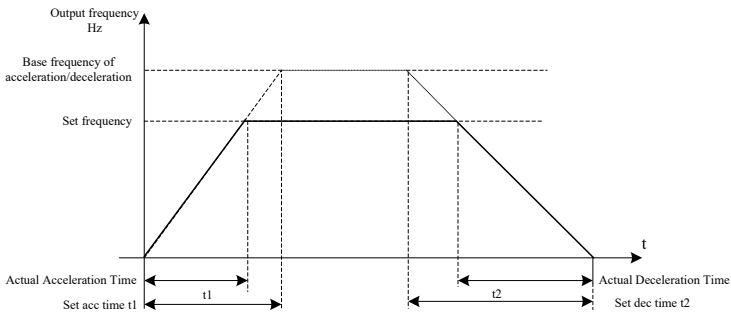

Fig.5-2 Illustration of acceleration/ deceleration time

- Group 1: F0-23、F0-24;
- Group 2: F7-03、F7-04;
- Group 3: F7-05、F7-06;
- Group 4: F7-07、F7-08;

F0-25	Over modulation voltage boost percentage	Range: 0%~10%	Default: 3%
-------	--	---------------	-------------

This parameter is used to improve the voltage output ability of the inverter constant power area assuming that the rated voltage is 100%. The bigger the value, the better the improving ability, but the more waves in current. so be careful on the operation. Generally, there is no need to change it.

F0-26	Carrier frequency	Range:0.5kHz~16.0kHz	Default: model dependent
-------	-------------------	----------------------	--------------------------

This function is used to adjust the carrier frequency of the inverter. By adjusting the carrier frequency, the motor noise can be reduced, and the resonance of the mechanical system can be avoided, so that the leakage current to earth and the interference of the inverter can be reduced.

When the carrier frequency is low, the output current higher harmonic component is increased, the motor loss is increased, and the motor temperature rise is also be increased.

When the carrier frequency is high, this motor loss is reduced, and the motor temperature is decreased, but both inverter loss and temperature rise will be increased and so will the interference.

Adjusting carrier frequency will have influences on below items:

Carrier frequency	Low → high
Motor noise	High → low
Output current waveform	Poor → good
Motor temperature rise	High → low
Inverter temperature rise	Low → high
Leakage current	Low → high
External radiation interference	Low → high

The default setting of the carrier frequency is different of inverters with different power. Although users can modify it according to their own need, still need to pay attention of these: if setting the carrier frequency higher than the default, the heat sink temperature will rise, so users should derate to use the inverter or it has the risk of temperature alarm.

Inverter power	Carrier frequency range	Default of carrier frequency
0.75Kw~5.5Kw	0.5kHz~16.0kHz	6.0kHz
7.5Kw~75Kw	0.5kHz~16.0kHz	4.0kHz
90Kw~450Kw	0.5kHz~16.0kHz	2.0kHz

F0-27	Carrier frequency adjustment with temperature	Range: 0~ 1	Default: 1
-------	---	-------------	------------

0: Invalid

1: Valid: the inverter can adjust the carrier frequency according to its own temperature, with which it can decrease the possibility to have overheat alarm.

F0-28	Initialization parameters	Range: 0~ 4	Default: 0
-------	---------------------------	-------------	------------

0:No operation.

1:Restore factory parameters, except motor parameters, record information and F0-20.

2:Clear the record information, including error record group U0, accumulated power-on time F7-33, accumulated running time F7-34 and power consumption F7-72.

3:Backup the current user parameters.

4:User parameter backup recovery.

F0-29	LCD upload or download parameter selection	Range: 0~ 4	Default: 0
-------	--	-------------	------------

Download is that function code parameter values are stored to LCD by inverter.

Upload is that the inverter parameters stored values are written to inverter by LCD , Therefore, LCD should first be downloaded prior to the upload parameters parameter.

0: no function

1: Download parameter to LCD

2: only upload F4 function parameters

3: Upload parameters except the F4 group

4: Upload all the parameters

5.2 Group F1 Start-stop Control Function Group

F1-00	Start mode	Range: 0~2	Default: 0
-------	------------	------------	------------

0: Direct start: when the DC brake time is non-zero value, it can perform DC braking before getting start, which suits for the applications where reverse rotation is likely to occur when small inertial loads are getting start.

1: Speed tracking restart: first of all ,the inverter makes an estimate of motor speed and direction ,then starts at the frequency in accordance with the tracked motor speed. The rotating motor is running smoothly without surge. It is suitable for the restart upon transient power failure of large inertial loads.

2: Pre-excited start of asynchronous motor: establish a magnetic field before running before it's used in asynchronous motor, for the purpose to decrease the current surge on start.

F1-01	Rotational speed tracking mode	Range: 0~2	Default: 0
-------	--------------------------------	------------	------------

To complete the speed tracking process within the shortest time, and then to select the mode of inverter tracking motor speed.

0: To track from the frequency on power failure, usually choose this mode.

1: To track from target frequency, usually used in restart after a long period of power supply off .

2: To track from the maximum frequency, and is suitable for the general power generating loads.

F1-02	Max current of rotational speed tracking	Range: 30%~150%	Default: 100%
F1-03	Rotational speed tracking speed	Range: 1~100	Default: 20

In speed tracking restart mode to select the current speed of the rotation tracking. The bigger the parameter value, the faster the tracking speed. But too fast speed may result in unreliable tracking.

F1-04	Startup frequency	Range: 0.00Hz~10.00Hz	Default: 0.00Hz
F1-05	Startup frequency holding time	Range: 0.0s~100.0s	Default: 0.0s
F1-06	Startup DC braking current	Range: 0%~100%	Default: 0%
F1-07	Startup DC braking time	Range: 0.0s~100.0s	Default: 0.0s

DC break at start is used when the motor is getting to restart after stop completely.

If the start mode is the direct start, when starting, the inverter firstly performs startup DC break according to the set startup DC brake current, and then starts to running after the set startup DC brake time. The larger the DC brake current, the larger the brake force.

The startup DC brake current is regarded as the percentage of rated current of inverter.

F1-08	Acceleration/Deceleration frequency curve selection	Range: 0~1	Default: 0
-------	---	------------	------------

0: Linear

1: S-curve

F1-09	Acceleration time proportion of S-curve start segment	Range: 0.00%~80.00%	Default: 20.0%
F1-10	Deceleration time proportion of S-curve start segment	Range: 0.00%~80.00%	Default: 20.0%
F1-11	Acceleration time proportion of S-curve end segment	Range: 0.00%~80.00%	Default: 20.0%
F1-12	Deceleration time proportion of S-curve end segment	Range: 0.00%~80.00%	Default: 20.0%

This parameter is used to set the non-impact slow start when drives start acceleration. The acceleration/deceleration curves are adjusted to different degrees of S-curve by the set value. Using the S-curve to acceleration or deceleration, the drives will make different acceleration /deceleration curves according to the original acceleration /deceleration time.

Tips: When acceleration/deceleration time=0, S-curve function is invalid.

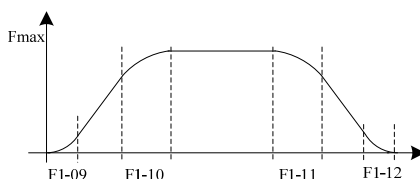

Fig.5-3 Illustration of S-curve Acceleration/deceleration

F1-13	Stop mode	Range: 0~1	Default: 0
-------	-----------	------------	------------

0: deceleration stop: after the stop command is valid, the inverter reduces the output frequency according to deceleration mode and the defined acceleration/deceleration time, and will stop after the frequency drops to zero

1: free stop: after the stop command, the inverter stops the output immediately. Then the load stops freely according to the mechanical inertia.

F1-14	Initial frequency of stop DC braking	Range: 0.00Hz~F0-14	Default: 0.00 Hz
-------	--------------------------------------	---------------------	------------------

On the deceleration stop process, it start to DC brake when reach to this frequency. It's easy to cause over voltage if set too large of this value.

F1-15	Waiting time of stop DC braking	Range: 0.0s~100.0s	Default: 0.0s
-------	---------------------------------	--------------------	---------------

When the running frequency decelerates to the start frequency of stop DC brake, firstly the inverter stop the output for a while, then start the DC brake process. It's used to avoid the over current fault if braking at a high speed.

F1-16	Stop DC braking current	Range: 0%~100%	Default: 0%
-------	-------------------------	----------------	-------------

This parameter is used to set the percentage of the DC brake current, and set 100% as the rated current. The larger the brake current, more obvious the brake effect is. But it's not suitable to set F1-17 too large if the braking current is too large.

F1-17	Stop DC braking time	Range: 0.0s~36.0s	Default: 0.0s
-------	----------------------	-------------------	---------------

This parameter is used to set the holding time of the DC brake. It has no DC brake process if the value is 0.

F1-21	Demagnetization time	Range: 0.01s~3.00s	Default: 0.50s
-------	----------------------	--------------------	----------------

This parameter is used to set the waiting time from the free stop to the next start.

F1-23	Nonstop at instantaneous stop mode selection	Range: 0~2	Default: 0
-------	--	------------	------------

This parameter is used to prevent the stop for bus under voltage which is caused by voltage drop of the power grid. It's mostly used in draught fan etc.

0: Ineffective. It's still running with the given frequency when it has a momentary power-off, but may stop for the under voltage problem.

1: Adjusting the decelerating speed automatically. When the power is off, adjusting the speed automatically to keep the inverter running still, then accelerating to the target frequency when the voltage is recovered. If the time is too long of power-off, the inverter will also stop for the under voltage problem.

2: Decelerating to stop. When it has a momentary power-off or voltage dip, the inverter will decelerate to stop according to F1-24. It needs a start signal to restart.

F1-24	Deceleration time of nonstop at instantaneous stop	Range: 0.0s to 100.0s	Default: 10.0s
F1-25	Effective voltage of nonstop at instantaneous stop	Range: 60% to 85%	Default: 80%

This parameter is the threshold value to judge if the power grid has a momentary power-off. When the bus voltage is less than F1-25, the inverter will decelerate to keep stable of the bus voltage according to F1-23. 100% correspond to the voltage class of the inverter.

F1-26	Recovery voltage of nonstop at instantaneous stop	Range: 85% to 100%	Default: 90%
-------	---	--------------------	--------------

This parameter is the threshold value to judge if the power grid has return to normal. When the bus voltage is more than F1-26, the inverter will not decelerate. When the holding time >F1-27, the inverter start to accelerate to the set frequency. 100% correspond to the maximum voltage class of the inverter.

F1-27	Detection time of instantaneous stop nonstop recovery voltage	Range: 0.0s to 300.0s	Default: 0.3s
-------	---	-----------------------	---------------

This parameter is used for judging the recovery time of power grid voltage. It start to count time when the voltage is higher than F1-26, else otherwise clear to 0.

F1-28	Auto-regulation gain of nonstop at instantaneous stop	Range: 0 to 100	Default: 40
F1-29	Auto-regulation integral time of nonstop at instantaneous stop	Range: 0 to 100	Default: 20

It's effective only when the nonstop at instantaneous stop mode choose F1-23 for the usage to adjust the speed, and usually no need to modify it.

5.3 Group F2 V/F Control Parameter

This group of function is only effective for V/F control (F0-03=2), but not effective for the vector control.

V/F control is applicable to the general loads such as draught fans and pumps etc, or the applications where one inverter drives multiple motors, or the inverter power is one level lower or two levels higher than the motor power.

F2-00	V/F curve setting	Range: 0~7	Default: 0
-------	-------------------	------------	------------

Fan and pump load types can choose square V/F control.

0: Straight V/F curve. It is suitable for common constant torque load.

1: Multiple point V/F curve. It is suitable for the special loads such as dehydrator and center fugal machine.

2: square V/F curve. It is suitable for the centrifugal loads such as fan and pump.

3~5: Respectively correspond to power 1.7, power 1.5 and power 1.3 of the V/F curve, in places between straight line and square line.

6: VF complete separation mode. The output frequency and output voltage is independent with each other at the moment, and the output frequency is determined by the frequency source, while output voltage is determined by F2-15 (VF separation voltage source).

7: VF half separation mode. V and F are proportional on this condition, but the proportion can be set by voltage source F2-15, and the relationship of V and F are related to the rated voltage and rated frequency of Group F1 motor.

Assuming that voltage input is X (X vary between 0~100%), so the relationship of output voltage and output frequency is:

$$V/F=2*X*(\text{rated voltage of the motor}) / (\text{rated frequency of the motor})$$

F2-01	Torque boost	Range: 0.0%~30.0%	Default: 0.0%
F2-02	Cut-off frequency of torque boost	Range: 0.00 Hz~ F0-14	Default: 25.00Hz

To compensate the characteristic of V/F control low frequency torque, it can boost the output voltage of the inverter at the time of low frequency.

If setting the torque boost too large, the motor is easily to overheat and the inverter is easily to over current. In general, the torque boost shall not exceed 8%.

Adjusting this parameter effectively can avoid over current on startup. For the relatively large loads, it is recommend to increase this parameter. For the small loads, this parameter value can be decreased. When the torque boost is set to 0.0, the inverter can adopt auto-torque boost.

Cutoff frequency of torque boost: Under this frequency, the torque boost is effective; if it

exceeds this setup frequency, the torque boost is ineffective. For details please refer to Fig. 5-4.

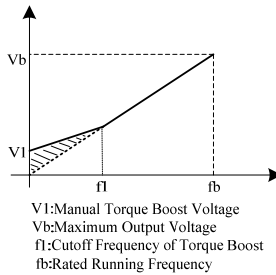

Fig.5-4 Illustration of Manual Torque Boost

F2-03	Multi-point V/F frequency 1 (F1)	Range: 0.00Hz to F2-05	Default: 3.00Hz
F2-04	Multi-point V/F voltage 1 (V1)	Range: 0.0% to 100.0%	Default: 8.0%
F2-05	Multi-point V/F frequency 2 (F2)	Range: F0-05 to F2-07	Default: 10.00 Hz
F2-06	Multi-point V/F voltage 2 (V2)	Range: 0.0% to 100.0%	Default: 20.0%
F2-07	Multi-point V/F frequency 3 (F3)	Range: 0.00Hz to 50.00Hz	Default: 50.00 Hz
F2-08	Multi-point V/F voltage 3 (V3)	Range: 0.0% to 100.0%	Default: 100.0%

Six parameters from F2-03~F2-08 define multi segment of V/F curves.

The setup value of V/F curve is generally set according to the characteristics of the motor load.

Caution: $V1 < V2 < V3$, $F1 < F2 < F3$. If setting the voltage too high in low frequency, the motor may be overheat even burned, and the inverter may have speed loss for over current or current protection.

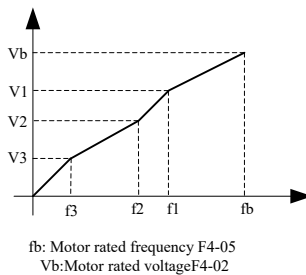

Fig.5-5 schematic diagram for V/F curve setup

F2-09	Slip compensation ratio	Range: 0.0% to 200.0%	Default: 50.0%
-------	-------------------------	-----------------------	----------------

Setting this parameter can compensate the slip in the V/F control mode due to load and reduce the change of rotation speed of the motor following the load change. In general 100% corresponds to the rated slip of the motor with rated load.

This parameter can be properly increased when the motor speed is lower than the giving speed,

otherwise decrease it. Usually there is no need to adjust it.

F2-10	V/F magnetic flux brake gain	Range: 0~200	Default: 100
-------	------------------------------	--------------	--------------

This parameter can restrain the bus voltage rising on the decelerating process. The bigger the value, the better the restrain effect.

Flux brake increases the motor current by increase the output voltage of inverter, thus restraining bus voltage rising by improving the feedback energy consuming ability. The larger the gain, the larger the motor current, so be careful on the operation. If on the occasions with braking resistance, its suggested setting this value to 0, otherwise it may come with errors on the decelerating process for the reason that the decelerating current is too large.

F2-11	Oscillation suppression gain	Range: 0 to 100	Default: model dependent
-------	------------------------------	-----------------	--------------------------

This parameter is used to restrain motor oscillation. Please increase this value properly when the motor has oscillation, but try to decrease it when there is no oscillation to avoid affecting V/F running. Usually there is no need to modify it.

F2-13	Slip compensation time	Range: 0.02s to 1.00s	Default: model dependent
-------	------------------------	-----------------------	--------------------------

This parameter is used to set the slip compensation time. Decreasing this value can increase the respond speed, but the speed fluctuation may be enlarged. Increasing this value can improve the stability of speed, but the respond speed decreased. Usually there is no need to modify it.

F2-15	Output voltage source for voltage and frequency separation	Range: 0~7	Default: 0
-------	--	------------	------------

0: Digital setting (F2-16).

1: AI1

2: AI2

3: Multi-segment command

4: Simple PLC

5: PID

6: Communication giving

7: Pulse setting (HDI)

100.0% corresponds to the rated motor voltage.

F2-16	Voltage digital setting for V/F separation	Range: 0 V ~ rated motor voltage	Default: 0
-------	--	----------------------------------	------------

This parameter is used to set the V/F separation voltage and the voltage output value when voltage source is digital setting value.

F2-17	Voltage rise time of V/F separation	Range: 0.0s to 3000.0s	Default: 1.0s
-------	-------------------------------------	------------------------	---------------

This parameter is used to set the acceleration time of the output voltage from 0 to rated

voltage when V/F separates.

F2-18	Voltage decline time of V/F separation	Range: 0.0s to 3000.0s	Default:1. 0s
-------	--	------------------------	---------------

This parameter is used to set the deceleration time of the output voltage from rated voltage to 0 when V/F separates.

F2-19	Stop mode selection upon V/F separation	Range: 0~1	Default:0
-------	---	------------	-----------

0: Frequency is independent with voltage declining time.

1: Frequency declining after voltage declines to 0.

5.4 Group F3 Vector Control Parameter

Group F2 function code is effective only for vector control, that is to say , it's effective when F0-03=0 shown active, and it's ineffective when F0-03=2.

F3-00	Switchover frequency 1	Range: 1.00Hz to F3-02	Default: 5.00Hz
F3-02	Switchover frequency 2	Range: F3-00 to F0-14	Default: 10.00Hz
F3-04	Speed loop proportional gain at low frequency	Range: 1.0 to 10.0	Default: 4.00
F3-05	Speed loop integral time at low frequency	Range: 0.01s to 10.00s	Default: 0.50s
F3-06	Speed loop proportional gain at high frequency	Range: 1.0 to 10.0	Default: 2.0
F3-07	Speed loop integral time at high frequency	Range: 0.01s to 10.00s	Default: 1.00s

The speed dynamic response characteristics of the vector control can be adjusted by setting the proportional coefficient and integration time of the speed regulator. Increasing the proportional gain or reducing the integration time both can accelerate the dynamic response of the speed loop. However, the proportional gain is too large or the integration time is too short both can cause the oscillation of the system.

Proposed adjustment method:

If the factory default parameters can't meet the requirements, thus the relevant parameters values should be subject to fine tuning. Firstly increasing the proportional gain to ensures no oscillation to the system; then reducing the integration time to make the system have quick response characteristic but small overshoot.

Caution: Improper PI parameter setting may result in the large speed overshoot, and even cause voltage fault when the overshoot drops.

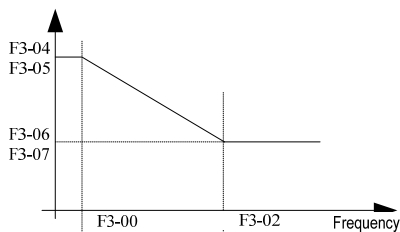

Fig.5-6 Switching diagram of the speed loop PI parameter

F3-08	Speed loop integral property	Range: 0~1	Default:0
-------	------------------------------	------------	-----------

0: Integral takes effect on acceleration/ deceleration process, and it has fast response on fast acceleration occasions, but may cause overshoot.

1: Integral separation on acceleration/ decoration process, it can effectively reduce speed overshoot on fast acceleration occasions, but the respond speed will decrease.

F3-11	Torque adjustment proportional gain Kp	Range:0~30000	Default:2200
F3-12	Torque adjustment integral gain Ki	Range:0~30000	Default:1500
F3-13	Excitation adjustment proportional gain Kp	Range:0~30000	Default:2200
F3-14	Excitation adjustment integral gain Ki	Range:0~30000	Default:1500

Vector control current loop PI adjustment parameter can be obtained after the complete tuning of asynchronous motor, and there is no need to modify it generally.

The current loop integral adjuster doesn't take time as dimension, but setting the integral gain directly. If setting the current loop too large, it may have circuit oscillation. So when current oscillation or torque fluctuation is too big, it's better to manually decrease the PI proportion gain or integral gain.

F3-15	Vector flux braking gain	Range:0 to 200	Default:0
-------	--------------------------	----------------	-----------

This parameter can be used to restrain the bus voltage rising on the deceleration process, the bigger the value, the better the suppression effect

It's by increasing output voltage of inverter to increase the motor current, thus improve the consumption ability of the feedback energy for flux brake to restrain the bus voltage rising. Take care that the bigger the gain, the bigger the motor current. At the same time, it's suggested to set this value to zero on occasions with brake resistor, otherwise it may have fault cause by larger current on deceleration process.

F3-16	Field weakening torque correction ratio	Range:50% to 200%	Default: 100%
-------	---	-------------------	---------------

This parameter is used to revise the torque value on constant power area, and there is no need to modify it generally.

F3-17	Slip compensation gain	Range:50% to 200%	Default: 100%
-------	------------------------	-------------------	---------------

This parameter is used to adjust the steady speed precision of the motor. When the rotation speed is too large, the parameter need to be adjusted smaller and vice versa.

F3-18	Speed loop feedback filter time constant	Range:0.000s to 1.000s	Default: 0.015s
-------	--	------------------------	-----------------

This parameter is used to set the filter time constant of speed feedback value. Increasing this value can improve the speed stabilization, but decrease the respond speed; while decreasing this value can improve the respond speed, but low down the speed stabilization. There is no need to modify it generally.

F3-19	Speed loop output filter time constant	Range:0.000s to 1.000s	Default: 0.000s
-------	--	------------------------	-----------------

This parameter is used to set the filter time constant for torque giving value, and it's useful to improve the stabilization of rotation speed. Generally, there is no need to set.

F3-20	Source of power-driven torque upper limit	Range:0~4	Default: 0
-------	---	-----------	------------

0: F3-21

1: AI1, AI line setting refers to F5-15~F5-19; multi-point curve setting refer to F5-45 and group FE.

2: AI2, AI line setting refers to F5-20~F5-24; multi-point curve setting refer to F5-45 and group FE.

3: Communication giving, it's written in directly by the host machine communication address, in which 100% correspond to F3-21. For details please refer to appendix A SSI3300 Modbus communication protocol.

4: Pulse giving, please refer to function code F5-30~F5-33 setting description, in which 100% correspond to F3-21.

F3-21	Power-driven torque upper limit	Range:0.0% to 200.0%	Default: 150.0%
-------	---------------------------------	----------------------	-----------------

This parameter is used to set the power-driven torque upper limit of the inverter. It's power-driven when the actual direction of the motor is same as the torque direction, otherwise it's braking.

On occasions which power-driven torque and braking torque need different setting value, it can set them separately by F3-21 and F3-23. For example on the occasion with cam load, for it has periodic conversion of power-driven and braking status, at this moment decreasing the braking torque upper limit F3-23 can effectively decreasing the bus voltage rising and not affect normal load carry.

F3-22	Upper limit source of braking torque	Range:0~4	Default: 0
-------	--------------------------------------	-----------	------------

0: F3-23

1: AI1, AI line setting refers to F5-15~F5-19, multi-point curve setting refers to F5-45 and group FE.

2: AI2, AI line setting refers to F5-20~F5-24, multi-point curve setting refers to F5-45 and

group FE.

3: Communication giving, it's written in directly by the host machine communication address, in which 100% correspond to F3-21. For details please refer to appendix A SSI3300 Modbus communication protocol.

4: Pulse giving, please refer to function code F5-30~F5-33 setting description, in which 100% correspond to F3-23.

F3-23	Braking torque upper limit	Range:0.0% ~ 200.0%	Default: 150.0%
-------	----------------------------	---------------------	-----------------

This parameter is used to set the brake torque upper limit. It's power-driven when the actual direction of the motor is same as the torque direction, otherwise it's braking.

5.5 Group F4 Motor Parameter

F4-00	Auto-tuning selection	Range:0~2	Default: 0
-------	-----------------------	-----------	------------

Caution: Prior to tuning, it must set the correct rated parameters (F4-01 ~ F4-06) of the motor.

0: No operation, that is No-Tuning.

1:Static tuning, it is suitable for the occasion that motor and load is hard to take off so it can't have rotary tuning.

Operation description: Set this function code to 1 and then confirm to press the RUN key, the inverter will operate static tuning.

2: complete tuning

To ensure the dynamic control performance on the inverter, please select the rotary tuning, and the motor must be disconnected with the loads (no-load) in the process of the rotary tuning. After selection of rotary tuning, the inverter conduct static tuning firstly. At the end of static tuning, the motor will accelerate to 80% of the rated motor frequency in accordance with the setup acceleration time of F4-12 and maintain for a period of time. Then the motor will decelerate to zero speed in accordance with the setup acceleration time of F4-13, by this time the rotary tuning is finished.

Operation description: Setting this function code to 2 and pressing RUN key, then the inverter will operate rotary tuning.

Tuning operation description:

When F4-00 is set to 1or 2, pressing ENTER key, "TUNE" will be displayed and flashed, then press RUN key to operate parameter tuning, at this time the displayed TUNE stops flashing. After the tuning is completed, the display will return back to stop status interface. Pressing STOP key can stop the tuning during the process.

The value of F4-00 will automatically restore to 0 at the end of tuning.

F4-01	Motor 1 rated power	Range: 0.1kW ~ 1000.0kW	Default: Model dependent
F4-02	Motor 1 rated voltage	Range: 0V ~ 1500V	Default: 380V
F4-03	Motor 1 pole number	Range: 2 ~ 64	Default: Model dependent
F4-04	Motor 1 rated current	Range: 0.1A ~ 6000.00 A<1>	Default: Model dependent
F4-05	Motor 1 rated frequency	Range: 0.00Hz ~ F0-14	Default: 50.00Hz

F4-06	Motor 1 rated rotation speed	Range: 0rpm ~ 60000rpm	Default: Model dependent
-------	------------------------------	------------------------	--------------------------

<1> F4-4 has 2 decimal places when the motor rated power F4-01>30KW, and it's 1 decimal place when F4-1<=30KW. The mentioned function codes are nameplate parameters, regardless whether use V/F control or vector control, the related parameters must be set according to nameplate.

In order to have better V/F or vector control performance, it's needed to tuning the parameters, and the accuracy of the tuning result is closely related to correctly set nameplate parameters.

F4-07	Motor 1 no-load current	Range: 0.01A ~ F4-04<1>	Default: Model dependent
F4-08	Motor 1 stator resistance	Range: 0.001Ω ~ 65.535Ω<2>	Default: Model dependent
F4-09	Motor 1 rotor resistance	Range: 0.001Ω ~ 65.535Ω<2>	Default: Model dependent
F4-10	Motor 1 mutual inductive	Range: 0.1Mh ~ 6553.5Mh<2>	Default: Model dependent
F4-11	Motor 1 leakage inductive	Range: 0.01Mh t~ 655.35Mh<2>	Default: Model dependent

<1> F4-4 has 1 decimal place when the motor rated power F4-01>30KW, and it's 2 decimal places when F4-1<=30KW.

<2> Decimal digit plus one when the motor rated power F4-01>30KW, and the decimal digits are showed as the table when F4-1<=30KW. Generally function code parameters F4-07~F4-11 are not on the nameplate, so it's gained by tuning. It can only have F4-07~F4-09 three parameters on static tuning while 5 function code on rotation tuning.

Note: motor parameter F4-02~F4-11 will change after modifying F4-01.

F4-12	Acceleration time of complete auto-tuning	Range: 1.0s~ 6000.0s	Default: 10.0s
F4-13	Deceleration time of complete auto-tuning	Range: 1.0s~ 6000.0s	Default: 10.0s

The above function codes respectively are the acceleration/ deceleration time of the complete tuning. Users can set the parameters properly according to the actual conditions.

5.6 Group F5 Input Terminal

SSI3300 series of inverters are equipped with 7 digital multi-function terminals (HDI can be used as high speed pulse input terminal) and 2 analog input terminals.

F5-00	DI1 terminal function	Range: 0~53	Default: 1
F5-01	DI2 terminal function	Range: 0~53	Default: 2
F5-02	DI3 terminal function	Range: 0~53	Default: 9
F5-03	DI4 terminal function	Range: 0~53	Default: 12

F5-04	DI5 terminal function	Range: 0~2	Default: 13
F5-05	DI6 terminal function	Range: 0~53	Default: 0
F5-06	HDI terminal function	Range: 0~53	Default: 0

This parameter is used to set the corresponding function of the digital multi-function terminals, for more details please refer to below form.

Tab.5-1 DI terminal function description

Set value	Function	Description
0	No function	Even when there is signal input, the inverter still has no action. The no operation function can be set on the untapped terminals so as to prevent errors.
1	Forward rotation (FWD)	Control the forward rotation and reverse rotation of the inverter via the external terminals.
2	Reverse rotation (REV)	
3	Three-line mode running control	This terminal is used to confirm that the inverter running mode is three-line control mode.
4	Forward Jog (FJOG)	FJOG refers to Jog forward rotation, while RJOG refers to Jog reverse rotation. For details regarding frequency and Jog acceleration/deceleration time during the Jog running, refer to F7-00, F7-01 and F7-02 function codes.
5	Reverse Jog (RJOG)	
6	Terminal UP	When the frequency is given by the external terminals, it is used as increment and decrement commands of frequency modification. When the frequency source is set to digital setup. The change rate of Up/Down is up to F5-12.
7	Terminal DOWN	
8	Free stop	The inverter locks the output, and the motor stop process is beyond the inverter control. It is the general method adopted when there is huge load and no requirement for the stop time.
9	Fault reset (RESET)	External fault reset function. It is the same as the function of RESET key on the keyboard.
10	Running pause	The inverter decelerates to stop, but all the running parameters are in memory status, such as PLC parameter, swing frequency parameter and PID parameter. After this signal disappears, the inverter restores to the status before stopping.
11	External fault normally open input	After the external fault signal is sent to the inverter, the inverter reports fault and stops.
12	MS speed terminal 1	It can realize 16 segment of setting through the combination of digital status of these four terminals. More details please refer to table 5-2.
13	MS speed terminal 2	
14	MS speed terminal 3	
15	MS speed terminal 4	

Set value	Function	Description
16	Speed-up/speed-down time selection terminal 1	It can select four types of speed-up/speed-down time through the combination of digital status of these two terminals. More details please refer to table 5-3.
17	Speed-up/speed-down time selection terminal 2	
18	Frequency source Switching	It can switch the frequency source of main frequency source and F0-10 setting through this terminal. For more details please refer to table 5-3.
19	UP and DOWN setup clear (terminal and keyboard)	When the frequency reference is digital frequency reference, this terminal can be used to clear the frequency value modified by UP/DOWN and thus restore the reference frequency to the setup value of F0-11.
20	Running command switching terminal	When the command source is not keyboard, it performs switching between terminal control and keyboard control via this terminal. When the command source is communication, it performs switching between communication control and keyboard control via this terminal.
21	Speed-up/speed-down prohibited	Protect the inverter from affecting by the external signals (except stop command), and maintain the current frequency.
22	PID Pause	PID is inactive temporarily, and the inverter maintains the current frequency output.
23	PLC status reset	PLC pauses during the execution process. When it reruns, it can effectively restore to the initial status of simple PLC via this terminal.
24	Swing frequency Pause	The inverter output with central frequency. Swing frequency pauses.
25	Timer trigger input	Timer trigger input signal, when the valid time reached the set close or break time, thus the timer output function is effective. It need to work cooperatively with NO.17 function, F7-39 and F7-40 of Y1 output.
26	Brake command	When this terminal is enabled, the inverter conduct DC brake immediately. The brake current is set by F1-16.
27	External fault normally closed input	After the external fault signal is sent to the inverter, the inverter reports fault and stops.
28	Counter input	Counter pulse input terminal, work cooperatively with Fb-08 to realize the present counter function.
29	Counter reset	Clear the count value to zero.
30	Length count input	Input terminal of the length count, work cooperatively with

Set value	Function	Description
		Fb-05~Fb-07 to realize the fixed length features.
31	Length reset	Clear the length count to zero.
32	Torque control prohibited.	Prohibit the inverter to use torque control mode and the inverter switches to speed control.
33	Pulse frequency input	Pulse input terminal (only effective to HDI)
34	Frequency modification forbidden.	When this function is enable, the inverter will not respond to frequency.
35	PID action direction reverse.	When this function is enable, the direction of PID is opposite to that of FA-04.
36	External STOP terminal1	When command source F0-04 is operation panel, it can stop the inverter by this terminal which is equivalent to the STOP key on the panel.
37	Command source switchover terminal 2	It's used to switch between terminal control and communication control.
38	PID integral pause	When this terminal is enable, the PID integral will pause, but PID proportion and differential adjustment are still valid.
39	Switchover between main frequency source X and preset frequency	When this terminal is enable, use preset frequency (F0-11) to replace frequency source X.
40	Switchover between auxiliary frequency source Y and preset frequency	When this terminal is enable, use preset frequency (F0-11) to replace frequency source Y.
41	Switchover between motor 1 and motor 2	Realize the switchover function between motor 1 and motor 2.
42	Reserved	
43	PID parameter switchover	Use the first group of PID parameter when this terminal is invalid, while use the second group PID parameter when it's valid. Details refers to group FA description.
44	Speed control/Torque control switchover	Make the inverter switch between torque control mode and speed control mode. When this terminal is invalid, the inverter run with the mode which Fd-10 (speed/torque control mode) defined, and it will switch to another mode when this terminal is valid.
45	Emergency stop	The inverter will stop with the maximum speed when this terminal is valid, and the current is in the upper limit on this period. This function is used on the occasion which requires

Set value	Function	Description
		stop as soon as possible when the system is in urgency.
46	External STOP terminal 2	It can use this terminal to make the inverter decelerate to stop on any control mode (panel control, terminal control and communication control). At this moment the decelerating time is fixed as decelerating time 2 (F7-04).
47	Deceleration DC injection braking	When this terminal is valid, the inverter decelerate to stop on the initial frequency of DC brake, then switch to the current brake status.
48	Clear the current running time	When this terminal is valid, the latest running time of the inverter will be cleared to zero. This function should work cooperatively with timer running (F7-36) and present time set value (F7-38).
49	Switchover between two-line mode and three-line mode	It's used to switch between three wire mode and two wire mode.
50	Reverse run prohibited	The inverter is prohibited to reverse when this terminal is valid.
51	User-defined fault 1	When this terminal is valid, the inverter output fault Err30.
52	User-defined fault 2	When this terminal is valid, the inverter output fault Err31.
53	Dormant input	Control the sleep function by external terminal. That is, sleep function is forcible to take effect when the switch is closed; when the switch is open, the inverter is forcible to exit the sleep status and enter the wake running status (irrelevant to PID operation).

Tab.5-2 Multistage command function description

K4	K3	K2	K1	Frequency setting	Corresponding Parameter
OFF	OFF	OFF	OFF	MS speed 0	FC-00
OFF	OFF	OFF	ON	MS speed 1	FC-01
OFF	OFF	ON	OFF	MS speed 2	FC-02
OFF	OFF	ON	ON	MS speed 3	FC-03
OFF	ON	OFF	OFF	MS speed 4	FC-04
OFF	ON	OFF	ON	MS speed 5	FC-05
OFF	ON	ON	OFF	MS speed 6	FC-06
OFF	ON	ON	ON	MS speed 7	FC-07

ON	OFF	OFF	OFF	MS speed 8	FC-08
ON	OFF	OFF	ON	MS speed 9	FC-09
ON	OFF	ON	OFF	MS speed 10	FC-10
ON	OFF	ON	ON	MS speed 11	FC-11
ON	ON	OFF	OFF	MS speed 12	FC-12
ON	ON	OFF	ON	MS speed 13	FC-13
ON	ON	ON	OFF	MS speed 14	FC-14
ON	ON	ON	ON	MS speed 15	FC-15

4 multi segment command terminals can be composed to 16 kinds of status, and the different status correspond to 16 command setting values, the details are shown in table 5-2.

Tab.5-3 Acceleration/Deceleration time selective terminal function description

Terminal 2	Terminal 1	Speed-up/speed-down time selection	Corresponding Parameter
OFF	OFF	Speed-up time 1	F0-23、F0-24
OFF	ON	Speed-up time 2	F7-03、F7-04
ON	OFF	Speed-up time 3	F7-05、F7-06
ON	ON	Speed-up time 4	F7-07、F7-08

F5-10	DI filter time	Range: 0.000s ~ 1.000s	Default: 0.010s
-------	----------------	------------------------	-----------------

It's used to set the sensitivity of the DI terminal. It's easily to be disturbed if confronted with digital input terminals. You can increase the parameter to improve the anti-jamming ability, but it will result in lower sensitivity of the terminal.

F5-11	Terminal command mode	Range: 0~3	Default: 0
-------	-----------------------	------------	------------

This parameter has defined 4 different ways which control the inverter through external terminals.

0: Two wire control mode 1: This mode is the most commonly used two wire mode. Forward running or reverse running is controlled by the command from FWD or REV terminal.

k1	k2	Command
0	0	Stop
1	0	Forward
0	1	Reverse
1	1	Stop

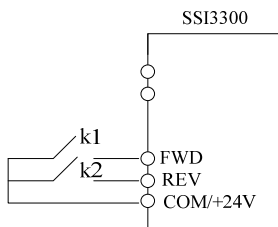

Fig.5-7 two wire control mode 1

1: Two wire control mode 2: Start/Stop terminal is the enabled terminal in this mode. The direction depends on the status of FWD/REV terminal.

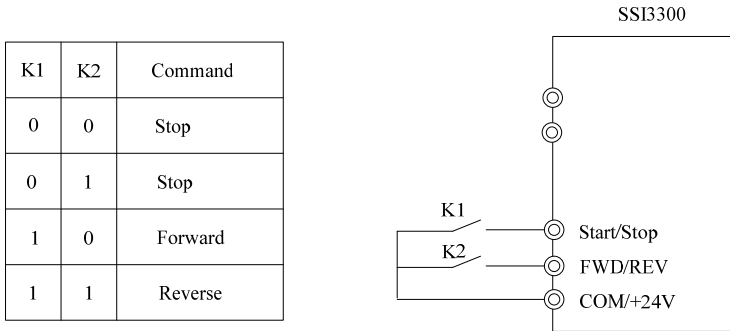

Fig.5-8 two wire control mode 2

2: **Three wire control mode 1:** Din is the enabled terminal on this mode. The direction is controlled by FWD or REV terminal. The pulse is effective and the Din terminal signal must be cut off at stop. Din is the multi-function input terminal; the corresponding terminal function should be defined as NO. 3 function “three wire mode running control”.

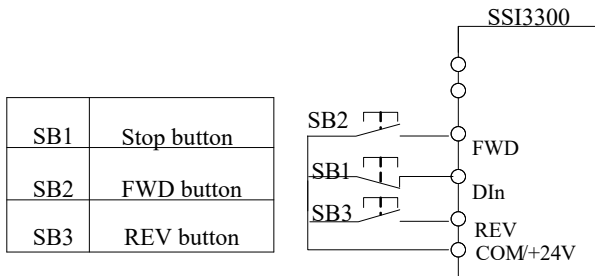

Fig.5-9 Three wire control mode 1

SB1: Stop button

SB2: Forward rotation button

SB3: Forward rotation button

Din is multifunctional input terminals of DI1 to DI5. In this way, it shall define the corresponding terminal functions as No.3 function “Three-line Mode Running Control”.

3: Three wire control mode 2: Din is the enabled terminal on this mode. FWD terminal gives the running command and the direction depends on the status of the REV terminal. The Din signal must be cut off at stop. Din is the multi-function input terminal; the corresponding terminal function should be defined as NO. 3 function “three wire mode running control”.

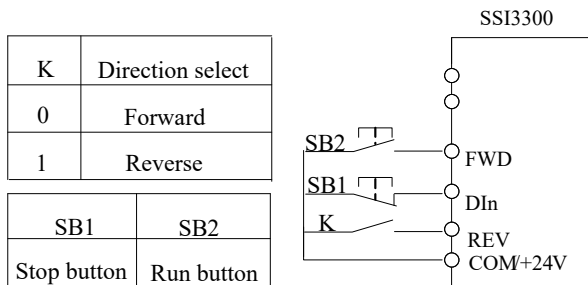

Fig.5-10 Three wire control mode 2

SB1: Stop button

SB2: Running button

Din is multifunctional input terminals of DI1 to DI5. In this way, it shall define the corresponding terminal functions as No.3 function “Three-line Mode running Control”.

F5-12	Terminal UP/DOWN rate	Range: 0.01Hz/s to 100.00Hz/s	Default: 1.00Hz/s
-------	-----------------------	-------------------------------	-------------------

Terminal UP/DOWN are used to adjust the rate of change when setting the frequency.

F5-13	Terminal effective logic 1	Range: 00000 to 11111	Default: 00000
-------	----------------------------	-----------------------	----------------

0: high level

1: low level

Unit's digit: DI1

Ten's digit: DI2

Hundred's digit: DI3

Thousand's digit: DI4

Myriabit: DI5

DI1~DI5 terminal effective level selection is used to set the valid status mode of the digital input terminals.

When choosing it's effective on high level, it's valid on the connection between the corresponding DI terminals and COM, but invalid on the disconnection.

When choosing it's effective on low level, it's invalid on the connection between the corresponding DI terminals and COM, but valid on the disconnection.

F5-15	A11 minimum input	Range: 0.00V to 10.00V	Default: 0.00V
F5-16	Corresponding setting of A11 minimum input	Range: -100.0% to 100.00%	Default: 0.0%
F5-17	A11 maximum input	Range: 0.00V to 10.00V	Default: 10.00V
F5-18	Corresponding setting of A11 maximum	Range: -100.0% to 100.00%	Default: 100.0%
F5-19	A11 filter time	Range: 0.00s to 10.00s	Default: 0.10s

The above function codes have defined the relationship between the analog input voltage and

analog input setup value. When the analog input voltage exceeds the setup maximum input or minimum input range, the excess part will be calculated as maximum input or minimum input.

When the analog input is current input, 1mA current equals to 0.5V voltage (AI2 setting is the same as AI1 setting).

In different applications, 100% of analog input corresponds to different nominal values. For details please refer to description of each part.

Several setting examples are shown in the following figures:

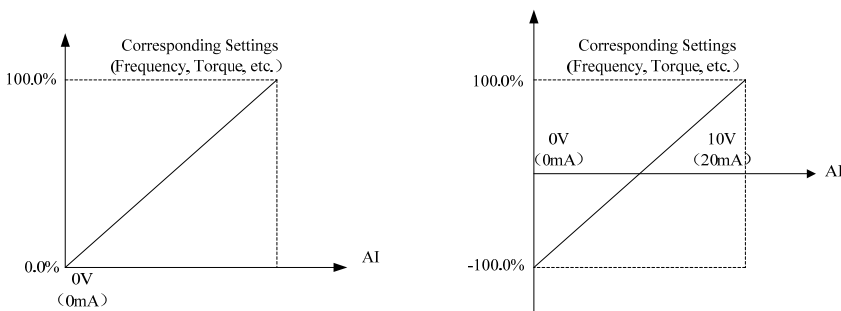

Fig.5-11 Corresponding Relationship between Analog Reference and Setting

F5-20	AI2 minimum input	Range: 0.00V to 10.00V	Default: 0.00V
F5-21	Corresponding setting of AI2 minimum input	Range: -100.0% to 100.00%	Default: 0.0%
F5-22	AI2 maximum input	Range: 0.00V to 10.00V	Default: 10.00V
F5-23	Corresponding setting of AI2 maximum	Range: -100.0% to 100.00%	Default: 100.0%
F5-24	AI2 filter time	Range: 0.00s to 10.00s	Default: 0.10s

It's the same as AI1.

F5-30	Pulse minimum input	Range: 0.00KHz to 50.00KHz	Default: 0.00KHz
F5-31	Corresponding setting of pulse minimum input	Range: -100.0% to 100.00%	Default: 0.0%
F5-32	Pulse maximum input	Range: 0.00KHz to 50.00KHz	Default: 50.00KHz
F5-33	Corresponding setting of pulse maximum input	Range: -100.0% to 100.00%	Default: 100.0%
F5-34	Pulse filter time	Range: 0.00s to 10.00s	Default: 0.10s

PULSE input quantization is similar to analog quantization.

F5-35	DI1 On delay time	Range: 0.0s to 3600.0s	Default: 0.0s
F5-36	DI1 Off delay time	Range: 0.0s to 3600.0s	Default: 0.0s
F5-34	DI2 On delay time	Range: 0.0s to 3600.0s	Default: 0.0s
F5-34	DI2 Off delay time	Range: 0.0s to 3600.0s	Default: 0.0s
F5-34	DI3 On delay time	Range: 0.0s to 3600.0s	Default: 0.0s

F5-34	DI3 Off delay time	Range: 0.0s to 3600.0s	Default: 0.0s
-------	--------------------	------------------------	---------------

It's used to set the delay time when DI terminals have status change. At present it only works for DI1, DI2 and DI3.

F5-41	AI1 function selection as DI terminal	Range: 0 to 53	Default: 0
F5-42	AI2 function selection as DI terminal	Range: 0 to 53	Default: 0

This parameter is used to set if take AI as digital terminal, and it has the same function as normal terminal when used as digital terminal.

Caution: the input range of AI keeps still as 0~10V, it's in high level when AI voltage>6V, while in low level AI voltage<4. It has hysteresis of 2V in the process. That is to say, AI rising from 0V in high level only when voltage >6V, and in low level only when voltage decreasing from >6V to 4V.

F5-44	AI effective mode selection as DI terminal	Range: 0X00~0X11	Default: 0X00
-------	--	------------------	---------------

This parameter is used set the electric level selection when AI is used as digital DI terminal.

0: High level is effective. AI rising from 0V in high level only when voltage >6V, and in low level only when voltage decreasing from >6V to 4V.

1: low level is effective. AI rising from 0V in low level only when voltage >6V, and in low level only when voltage decreasing from >6V to 4V.

Unit's digit: AI1;

Ten's digit: AI2.

F5-45	AI curve selection	Range: 00~22	Default: 00
-------	--------------------	--------------	-------------

This parameter is used for AI curve selection. Zero represent straight line, 1 and 2 both are 4-point curve. Every curve has its own setting function code.

Unit's digit: AI1

0: 2-point straight line F5-15~F5-19

1: multi-point curve 1: FE-00~FE-07

2: multi-point curve 2: FE-08~FE-15

Ten's digit: AI2

0: 2-point straight line F5-20~F5-24

1: multi-point curve 1: FE-00~FE-07

2: multi-point curve 2: FE-08~FE-15

Hundred's digit: reserved

F5-46	AI input type selection	Range: 00~11	Default: 00
-------	-------------------------	--------------	-------------

This parameter is used to set AI signal input type. AI signal input type need to in one-to-one correspondence with hardware AI input type (voltage type, current type) and it's beneficial to improve the accuracy and linearity of AI signal sampling.

5.7 Group F6 Output Terminal

SSI3300 series of inverter has standard configuration of 2 multi-function analog output terminals, 1 multi-function digital output terminal and 2 multi-function relay output terminals.

F6-00	Relay 1 output selection	Range: 00~45	Default: 2
-------	--------------------------	--------------	------------

F6-01	Relay 2 output selection	Range: 00~45	Default: 1
F6-02	Y1 output selection	Range: 00~45	Default: 1

The multifunctional digital output terminal function selection is as below:

Set value	Function	Description
0	No function	No function of terminal output.
1	In running	Means that the inverter is running with output frequency (0 value as option) and output ON signal.
2	Fault output	The inverter is in trouble and output ON signal.
3	Frequency Level detection FDT arrival	Refer to function code F7-22、 F7-23 for details
4	Frequency arrival	Refer to F7-24 for details.
5	In zero speed	The inverter is running with zero output frequency; output ON signal.
6	Motor overload pre-alarm	To judge according to overload predicted values before the motor electronic thermal protection take action, after exceeding the predicted values output ON signal. Details refers to F9-00~F9-02.
7	Inverter overload pre-alarm	After checking the inverter overload,to move up early 10s before the protection occurs, and output ON signal.
8	PLC cycle Finished	To send a pulse signal with width of 250ms as simple PLC running at the end of one-time cycle .
9	Running time off	The accumulated running time on the inverter is more than the setting time of ON signal, accumulated time is set by F7-20.
10	In frequency limited	When the setting frequency exceeds the upper or lower frequency, and the inverter output frequency reach the upper or lower frequency, it gives ON signal.
11	Ready for running	The main circuit and control circuit source power is established, the inverter is in running without protection to send ON signal.
12	A11>A12	The analog input A11 value is more than the other A12 's, output ON signal.
13	Frequency upper limit arrival	Output ON signal when the running frequency comes to the upper frequency F0-16.
14	Frequency lower limit arrival	Output ON signal when the running frequency comes to the lower frequency F0-18.
15	Under voltage status output	Output ON signal in the status of under voltage.
16	Communication	Communication setting please refer to appendix A.

	setting	
17	Timer output function	When the timer can realize the function of time relay, and valid time of timer input signal reaches the set close or open time, thus the timing output function is valid. It need to work in cooperatively with DI input NO.25 function and function code F7-39, F7-40.
18	Reverse running	Output ON signal when the inverter is in reverse running.
19	Reversed	
20	Set length arrived	Output ON signal when the detected length exceeds the set length
21	Torque limiting	Stalling protection function works automatically on torque limiting function.
22	Current 1 arrived	Refer to description of function code F7-45 and F7-46.
23	Frequency 1 arrived	Refer to description of function code F7-43 and F7-44.
24	Module temperature arrived	Output ON signal when inverter module radiator temperature (F7-32) reaches the set module temperature (F7-69).
25	Off load	Output ON signal when the inverter is in off load status.
26	Accumulated power-on time arrived	Output ON signal when accumulated power-on time (F7-33) exceeds the power-on arrived time set by F7-51.
27	Running time arrived	When timing function selection (F7-36) is effective, output ON signal after this running time arrived the setting time (F7-38).
28	Reserved	
29	Set count value arrived	Output ON signal when the count value reaches the set value of Fb-08.
30	Fixed count value arrive	Output ON signal when the detected length count value reaches the setting value of Fb-09.
31	Motor 1, motor 2 indication	Output ON signal when the present motor is motor 2.
32	Mechanical brake control output	Output ON signal when mechanical brake is effective, details refers to group L5.
33	Zero speed running 2	Output ON signal when output frequency is zero. The signal is also ON in stop status.
34	Frequency level detection FDT2 arrived	Please refer to description of F7-55 and F7-56.
35	Zero current status	Please refer to description of F7-59 and F7-60.
36	Software current overrun	Please refer to description of F7-61 and F7-62.
37	Frequency lower limit arrived and	Output ON signal when the running frequency reaches the upper limit. The signal is also ON in stop status.

	output on stop	
38	Alarm output	The inverter has alarm output when there is fault and the dealing mode of the fault is keep running.
39	Reserved	
40	AI1 input overrun	Output ON signal when AI1 analog input value is less than F7-67 (AI1 input protection lower limit) or more than F7-68 (AI1 input protection upper limit).
41~42	Reserved	
43	Frequency arrival 2	Please refer to description of F7-57 and F7-58.
44	Current arrival 2	Please refer to description of F7-63 and F7-64.
45	Fault output (no output on under voltage)	Output ON signal when it has fault on the inverter and no output on under voltage.

F6-04	FM terminal output selection	Range: 0~1	Default: 0
F6-05	FMR output selection	Range: 0~45	Default: 0

FM terminal can not only used as high speed pulse terminal(F6-04=0), but also used as switching value output terminal (F6-04=1) of open collector. When FM terminal is used as FMP, the maximum output frequency is up to F6-12, and the corresponding function output is up to F6-11.

F6-09	AO1 output selection	Range: 0~16	Default: 0
F6-10	AO2 output selection	Range: 0~16	Default: 0
F6-11	FMP output selection	Range: 0~16	Default: 0

Analog output AO1 and AO2 output range is 0V~10V, or 0mA~20mA.

The relationship of analog output range and the corresponding function is as below table:

Setup value	Function	Range
0	Running frequency	0~maximum output frequency, that is to say, 100% corresponds to the maximum frequency.
1	Setup frequency	0~maximum output frequency, that is to say, 100% corresponds to the maximum frequency.
2	Output current	0~2 times of the motor rated current, that is to say, 100% corresponds to 2 times motor rated current.
3	Output power	0~2 times of the rated power, that is to say, 100% corresponds to 2 times motor rated power.
4	Output voltage	0~1.2 times of the inverter rated voltage, that is to say, 100% corresponds to 1.2 times motor rated voltage.
5	AI1	0~10V (0~20mA), that is to say, 100% corresponds to 10V or 20mA.
6	AI2	0~10V (0~20mA), that is to say, 100% corresponds to 10V or 20mA.

7	Communication setup	0.0%~100.0%, refer to<M420 series inverter communication protocol> shown as Appendix for details
8	Output torque (absolute value)	0~2 times motor rated torque, that is to say, 100% corresponds to 2 times motor rated torque.
9	Length	0~2 times set length, 100% corresponds to 2 times set length.
10	Count value	0~2 times set count value, that is to say, 100% corresponds to 2 times set count value.
11	Motor rotation speed	0~ maximum frequency (corresponding speed of F0-14), that is to say, 100% corresponds to corresponding speed of F0-14.
12	Bus voltage	0V~1000V, that is to say, 100% corresponds to 1000V.
13	Puse input	0.01kHz~100.00kHz
14	Output current	100% corresponds to 1000.0A.
15	Output voltage	0V~1000V
16	Output torque (actual value)	-2 times motor rated torque~2 times motor rated torque

F6-12	FMP output maximum frequency	Range: 0.01~100.00KHz	Default: 50.00Hz
F6-13	AO1 minimum output	Range: -100.0% to F6-15	Default: 0.0%
F6-14	Minimum corresponds to AO1 output	Range: 0.00V to 10.00V	Default: 0.00v
F6-15	AO1 maximum output	Range: F6-13 to 100.0%	Default: 100.0%
F6-16	Maximum corresponds to AO1 output	Range: 0.00V to 10.00V	Default: 10.00V
F6-17	AO2 minimum output	Range: -100.0% to F6-19	Default: 0.0%
F6-18	Minimum corresponds to AO2 output	Range: 0.00V to 10.00V	Default: 0.00v
F6-19	AO2 maximum output	Range: F6-17 to 100.0%	Default: 100.0%
F6-20	Maximum corresponds to AO2 output	Range: 0.00V to 10.00V	Default: 10.00V

The above function codes have defined the relationship between output value and analog output. When the output value exceeds the maximum or minimum limit range, taking the limit value into operation.

When the analog output is current output, 1mA current corresponds to 0.5V voltage. The 100% output value corresponds to different value on different occasions. Please refer to below chart 5-12, there are a and b two different linear graph.

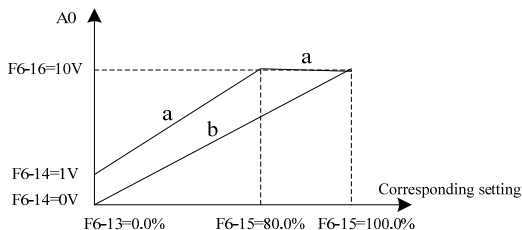

Fig.5-12 Analog output limitation corresponding relationship

F6-26	Relay 1 output delay	Range: 0.0s to 3600.0s	Default: 0.0s
F6-27	Relay 2 output delay	Range: 0.0s to 3600.0s	Default: 0.0s
F6-28	Y1 high level output delay	Range: 0.0s to 3600.0s	Default: 0.0s

It's used to set the delay time of inverter when responding to different output status change, such as the Y terminal status change or relay output status change.

F6-31	AO signal output type selection	Range: 00~11	Default: 00
-------	---------------------------------	--------------	-------------

It's used to set the AO signal output type. AO output signal type has to be in one-to-one correspondence with hardware AO output type (voltage type, current type).

5.8 Group F7 Auxiliary Function and Panel Display

F7-00	JOG running frequency	Range: 0.00 Hz to F0-14	Default: 6.00Hz
F7-01	JOG acceleration time	Range: 0.0s to 3000.0s	Default: 10.0s
F7-02	JOG deceleration time	Range: 0.0s to 3000.0s	Default: 10.0s

The above parameters are used to define the giving frequency and acceleration/deceleration time of the inverter on jogging. The Jog process is getting to started and to stop according to the start mode 0 (F1-00, direct start) and the stop mode 0 (F1-13, decelerating to stop).

The Jog acceleration time means the time required for the inverter to accelerate from 0Hz to the maximum output frequency (F0-14).

The Jog deceleration time means the time required for the inverter to decelerate from the maximum output frequency (F0-14) to 0Hz.

F7-03	Acceleration time 2	Range: 0.0s to 3000.0s	Default: 10.0s
F7-04	Deceleration time 2	Range: 0.0s to 3000.0s	Default: 10.0s
F7-05	Acceleration time 3	Range: 0.0s to 3000.0s	Default: 10.0s
F7-06	Deceleration time 3	Range: 0.0s to 3000.0s	Default: 10.0s
F7-07	Acceleration time 4	Range: 0.0s to 3000.0s	Default: 10.0s
F7-08	Deceleration time 4	Range: 0.0s to 3000.0s	Default: 10.0s

Speed up/down time can choose F0-23, F0-24 and the above three types of speed up/down time, all of them have the same meaning. For more details please refer to descriptions of F0-23 and F0-24.

It can select speed-up/down time 1 to 4 in the running process by different combination of multi-

functional digital input terminal DI. For more details please refer to function code F5-00~F5-04.

F7-09	Jump frequency 1	Range: 0.00 Hz to F0-14	Default: 0.00Hz
F7-10	Jump frequency 1 amplitude.	Range: 0.00 Hz to F0-14	Default: 0.00Hz
F7-11	Jump frequency 2	Range: 0.00 Hz to F0-14	Default: 0.00Hz
F7-12	Jump frequency 2 amplitude.	Range: 0.00 Hz to F0-14	Default: 0.00Hz

When the setting frequency is within the jump frequency, actual running frequency will be in the jump frequency boundary which is near to the set frequency. Setting jump frequency can keep the inverter off from the mechanical resonance point. These series of inverter can set 2 jump frequency point. If set the two contiguous jump frequency to the same value, there will be no function of the frequency here.

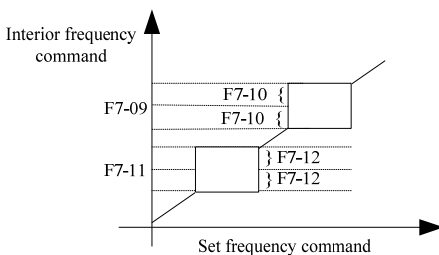

Fig.5-13 Jump frequency illustration

F7-15	Forward/Reverse rotation dead-zone time	Range: 0.0s to 3000.0s	Default: 0.0s
-------	---	------------------------	---------------

Setting the transient time on the zero frequency output when the inverter is on the transient process from the forward to reverse. You can refer to below chart.

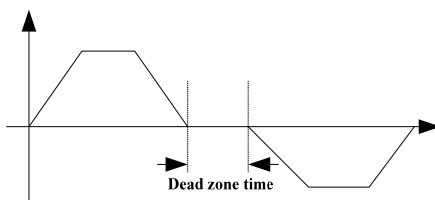

Fig.5-14 Forward/ reverse rotation dead zone illustration

F7-16	Keypad knob accuracy selection	Range: 0~8	Default: 0
-------	--------------------------------	------------	------------

This parameter is used to define the setting frequency resolution of the operation panel on monitor mode. Operate Up/Down to set the resolution for frequency plus or minus.

- 0: Default mode
- 1: 0.1Hz
- 2: 0.5Hz

- 3: 1Hz
- 4: 2Hz
- 5: 4Hz
- 6: 5Hz
- 7: 8Hz
- 8: 10Hz

F7-17	Running mode when set frequency is lower than the lower limit	Range: 0~2	Default: 0
-------	---	------------	------------

- 0: Run at frequency lower limit
- 1: Stop
- 2: Run at zero speed

It's used to select the running status when setting frequency is lower than the lower limit. In order to avoid the inverter run in long-term low speed, this function can be used to stop the machine.

F7-18	Droop rate	Range: 0.0% to 100.0%	Default: 0.0%
-------	------------	-----------------------	---------------

This function is used to distribute the load when multiple motors run with one load. Droop control means decreasing the output frequency with load increasing, so the motor with load decreases more frequency, thereby lowering the motor load and making multiple motors have uniform load. This parameter means the drop-out value of output frequency when the inverter output is at rated load.

F7-19	Delay time of stopping mode when set frequency is lower than the lower limit	Range: 0.0s to 600.0s	Default: 0.0s
-------	--	-----------------------	---------------

When setting frequency in lower than the lower limit and action selection is stop, delay the action with time F7-19.

F7-20	Setting accumulative running time.	Range: 0h to 65000h	Default: 0h
-------	------------------------------------	---------------------	-------------

Setting the inverter running time in advance. This function is invalid when set to 0.

When accumulated running time (F7-34) reaches this setting time, multi-function digital terminal output time arrival signal (multi-function output No.26) –ON signal, at the same time, inverter will alarm fault Err40 (accumulate time arrival fault).

F7-21	JOG preferred	Range: 0~1	Default: 0
-------	---------------	------------	------------

- 0: valid
- 1: invalid

F7-22	Frequency detection value (FDT1)	Range: 0.00 Hz to F0-14	Default: 50.00Hz
-------	----------------------------------	-------------------------	------------------

F7-23	Frequency detection hysteresis (FDT1 hysteresis)	Range: 0.0% to 100.0%	Default: 5.0%
-------	--	-----------------------	---------------

They are used to set the detected value of output frequency and hysteresis value of output action removed.

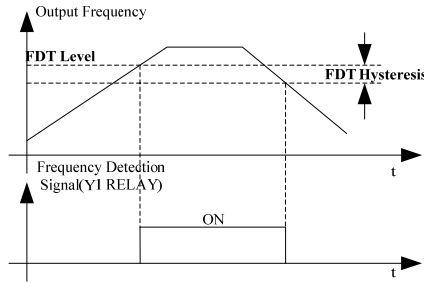

Fig.5-15 FDT electrical level illustration

F7-24	Detection range of frequency reached	Range: 0.0% to 100.0%	Default: 0.0%
-------	--------------------------------------	-----------------------	---------------

when the output frequency on the inverter reaches the setup frequency value, this function can be used to adjust the test amplitude as shown in below figure.

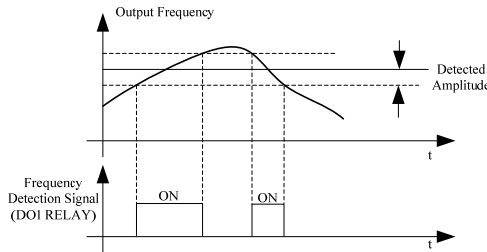

Fig.5-16 Illustration of detected amplitude on frequency arrival

F7-26	Cooling fan control	Range: 0~1	Default: 0
-------	---------------------	------------	------------

- 0: Fan continuous running
- 1: Fan running on inverter running.

It's used to choose the action mode of the cooling fan. If choose status 1, the fan keeps running on inverter running. When the inverter is stopped, the fan only run on the condition that heat temperature higher than 40°C, it will stop on condition that temperature is lower than 40°C.

If choose status 0, the fan keeps running all the time on power-on.

F7-27	STOP/RESET key function	Range: 0~1	Default: 1
-------	-------------------------	------------	------------

- 0: STOP/RESET key enabled only in keypad control.
- 1: STOP/RESET key enabled in any operation mode.

F7-28	Quick/JOG function selection	Range: 0~3	Default: 1
-------	------------------------------	------------	------------

Quick/Jog are multi-function key that can be set by this function code. It can switch through the key on both running or stop status,

- 0: Forward jog
Realize the function forward jog by Quick/Jog key on the panel.
- 1: Switch between forward and reverse rotation

Realize the function by Quick/Jog key to change the frequency direction, and this function is valid only when the command source is in operation panel channel.

2: Reverse Jog

Realize the function reverse jog by Quick/Jog key on the panel.

3: Switch between panel control and remote control (terminal or communication).

It means present command source switches to panel control (local operation). If the present command source is panel control, this key is invalid.

F7-29	LED display running parameters	Range: 0000~0xffff	Default: H.441F
-------	--------------------------------	--------------------	-----------------

This function code set the LED display parameters when inverter is running. If set one of the function code bit as “1”, the corresponding monitor parameter will display. When choose multi function code to display, it can switch by key “SHIFT” on the panel.

Caution: if this function code is set as H.0000, it will display the running frequency.

Example of setting:

Each hexadecimal value that correspond to the required display value has been calculated, like fig.5-17, the display value is in one-to-one correspondence with the set value. For example, if only need to display the bus voltage, set 0004 in F7-29 (H.0004); if it need to display multi value, just plus the corresponding values. For example, if it need to display bus voltage and output current, just calculate 0004+0010=0014, set 0014 in F7-29 (H.0014). if the plus result value is bigger than 10, respectively indicating it by A B C D E F to represent 10 11 12 13 14 15.

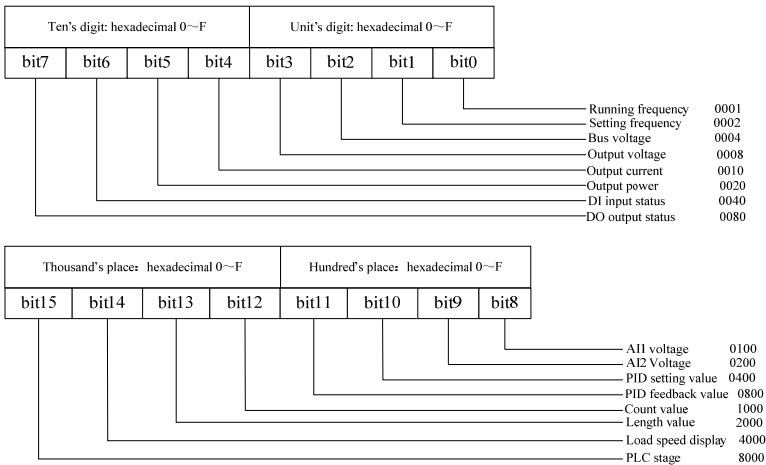

Fig.5-17 LED running display illustration

F7-30	LED display stop parameters	Range: 0000~0xffff	Default: H.0043
-------	-----------------------------	--------------------	-----------------

This function code set the LED parameter on inverter stop status. If set one of the function code bit as “1”, the corresponding monitor parameter will display. When choose multi function code to display, it can switch by key “SHIFT” on the panel.

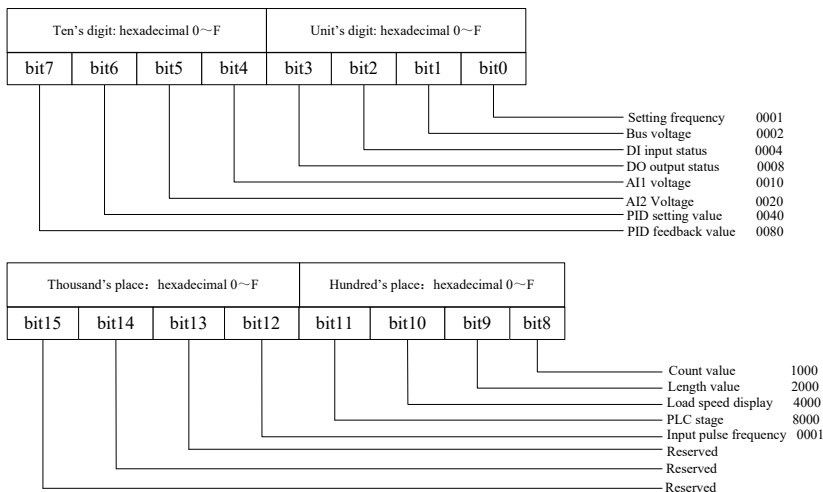

Fig.5-8 LED stop display illustration

Caution: if this function code is set as H0000, it will display the fault frequency.

For setting method please refer to F7-29 as fig.5-18, set the corresponding hexadecimal value in F7-30, thus it's stop display.

F7-31	Load speed display coefficient	Range: 0.001 to 655.00	Default: 1.000
-------	--------------------------------	------------------------	----------------

Through this parameter correspond the output frequency of inverter to load speed. It's usually used on the occasion which doesn't have high speed pulse but need to display load speed. Load speed (U1-14) = F7-31*running frequency. The unit can either be linear speed or Hz and specific value please set it according to the actual condition.

F7-32	Temperature of inverter module	Range: 12 \square to 100 \square	Default: measured value
-------	--------------------------------	--------------------------------------	-------------------------

Display the temperature of inverse module IGBT, but different inverse module may has different over temperature protection value.

F7-33	Accumulative power-on time	Range: 0h to 65535h	Default: measured value
-------	----------------------------	---------------------	-------------------------

Recording the accumulative power-on time of the inverter, and not record it when the time is less than 1 hour.

F7-34	Accumulative running time	Range: 0h to 65535h	Default: measured value
-------	---------------------------	---------------------	-------------------------

Recording the accumulative running time of the inverter, and not record it when the time is less than 1 hour.

F7-36	Current running time function	Range: 0~1	Default: 0
-------	-------------------------------	------------	------------

0: Disable

1: Enable:

F7-37	Current running time source	Range: 0~2	Default: 0
-------	-----------------------------	------------	------------

0: Digital setting F7-38

1: AI1 (take F7-38 as 100%)

2: AI2

F7-38	Setting of current running time	Range: 0.0min to 6500.0min	Default: 0.0 min
-------	---------------------------------	----------------------------	------------------

When F7-36 present running timing is valid, and choose 0:F7-38 for present time source; choose F7-27 for output, output ON signal when running time reaches the setting time. At the same time, the inverter alarm fault Err39 for running time arrival fault.

F7-39	High level timing	Range: 0.0s to 6000.0s	Default: 2.0s
-------	-------------------	------------------------	---------------

F7-40	Low level timing	Range: 0.0s to 6000.0s	Default: 2.0s
-------	------------------	------------------------	---------------

When the timer input terminal “connected” is longer than F7-39. its function output is connected.

When the timer input terminal ‘disconnected’ is longer than F7-40,its function output is disconnected.

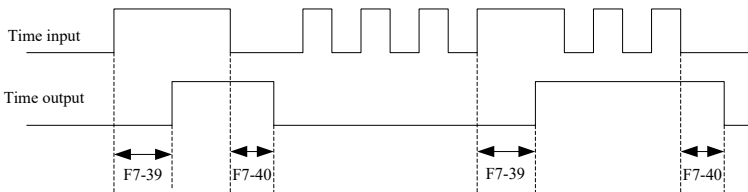

Fig.5-19 Timer input and output action diagram

F7-41	Start-up protection	Range: 0~1	Default: 1
-------	---------------------	------------	------------

0: Invalid

1:Valid

This parameters is used to improve the protection coefficient, if set to 1, there are two functions

1) When the running command is existed under power on, only remove the running command firstly can it eliminate the running protection status.

2) The running command is still existed when the inverter’s fault is reset, only remove the running command firstly can it eliminate the running protection status.

These actions can prevent the motor running automatically under no awareness to cause danger. if set it as 0 and the running command is existed under power on, the inverter will start directly.

F7-43	Frequency reached detection value 1	Range: 0.00Hz to F0-14	Default: 50.00Hz
-------	-------------------------------------	------------------------	------------------

F7-44	Range of frequency reached detection value 1	Range: 0.0% to 100.0%	Default: 0.0%
-------	--	-----------------------	---------------

When the output frequency reaches the rage of detected value 1 plus or minus, multi-function terminal output ON signal. For DO output action please refer to fig.5-16.

F7-45	Current detection level 1	Range: 0.0% to 300.0%	Default: 100.0%
F7-46	Current reached detection duration 1	Range: 0.0% to 300.0%	Default: 0.0%

When the output current reaches the range of detected value 1 plus or minus, multi-function terminal output ON signal.

F7-49	User password	Range: 0 to 65535	Default: 0
-------	---------------	-------------------	------------

If setting F7-49 for any non-zero number, the password protection is effective. You must input the right password the next time into the menu, otherwise you can't check or modify the function code. So please keep the password in mind.

If setting F7-49 for zero, the password will be cleared and make the protection function ineffective.

F7-50	Jump frequency during acceleration and deceleration	Range: 0 ~1	Default: 0
-------	---	-------------	------------

0: Invalid

1:Valid

F7-51	Setting power-on reached time	Range: 0h to 65530h	Default: 0h
-------	-------------------------------	---------------------	-------------

The timing function is invalid if set the function code to zero.

When the accumulated time of power-on reaches the setting value of F7-51, multi-function output terminal output ON signal.

F7-53	Frequency switch over point between acceleration time 1 and acceleration time 2	Range: 0.00Hz~F0-14	Default: 0.00Hz
F7-54	Frequency switch over point between deceleration time 1 and deceleration time 2	Range: 0.00Hz~F0-14	Default: 0.00Hz

When the running frequency on acceleration period is less than F7-53, choose acceleration time 2 (F7-03); when the running frequency on acceleration period is more than F7-53, choose acceleration time 1 (F0-23).

When the running frequency on deceleration period is more than F7-54, choose acceleration time 1 (F0-24); when the running frequency on deceleration period is less than F7-54, choose deceleration time 2 (F7-04).

F7-55	Frequency detection value (FDT2)	Range: 0.00Hz~F0-14	Default: 50.00Hz
F7-56	Frequency detect FDT2 hysteresis value	Range: 0.0% to 100.0%	Default: 5.0%

They have the same meaning as FDT1, for details please refer to F7-22, F7-23 and fig.5-15.

F7-57	Frequency reached detection value 2	Range: 0.00Hz to F0-14	Default: 50.00Hz
F7-58	Range of frequency reached detection 2	Range: 0% to 100%	Default: 0.0%

They have same meaning as frequency reached detection time 1, for details please refer to F7-43, F7-44 and fig.5-16.

F7-59	Zero current detection level	Range: 0% to 300%	Default: 10.0%
-------	------------------------------	-------------------	----------------

F7-60	Zero current detection delay time	Range: 0% to 300%	Default: 1.00s
-------	-----------------------------------	-------------------	----------------

When the output current on running process is less than or equivalent to the detected value, and the holding time exceeds the zero current detection delay time; the multi-function terminal choose NO.35 function, output ON signal.

F7-61	Current output detection amplitude	Range: 20.0% to 400.0%	Default: 200.0%
F7-62	Current output detection amplitude delay time	Range: 0.00s to 300.00s	Default: 0.00s

When the inverter in running and output current is more than the amplitude detected value F7-61, and the holding time exceeds software overcurrent detection delay time F7-62; the multi-function terminal choose NO.36 function, output ON signal.

F7-63	Current detection level 2	Range: 20% to 300%	Default: 100.00%
F7-64	Current reached detection duration 3	Range: 0.0% to 300.0%	Default: 0.00%

They have same meaning as current reached detection 1, for details please refer to descriptions of F7-45 and F7-46.

F7-65	LED display running parameters 2	Range: 0x0~0x1FF	Default: 0x00
-------	----------------------------------	------------------	---------------

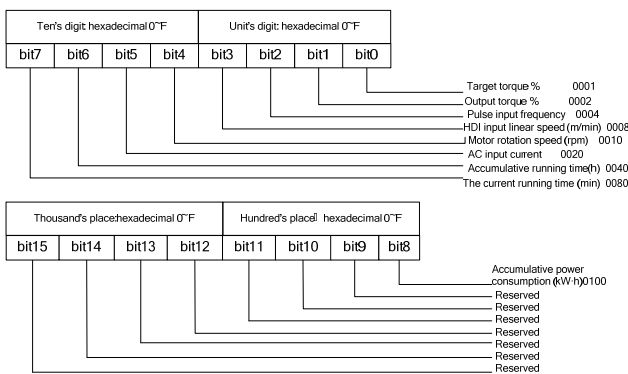

Fig.5-20 LED running display illustration

For setting method please refer to F7-29 as fig.5-20. Setting the corresponding hexadecimal value of the required value in F7-65, then it's get to running display.

F7-67	A11 input voltage lower limit	Range: 0.00V to F7-68	Default: 2.00V
F7-68	A11 input voltage upper limit	Range: F7-67 to 11.00V	Default: 8.00V

When analog input value A11 is less than F7-67, or A11 input is more than F7-68, the multi-function terminal will output ON signal of "A11 input exceeds the limit". It's used to detect if A11 input voltage is within the setting range.

F7-69	Module temperature threshold	Range: 0 to 90	Default: 70
-------	------------------------------	----------------	-------------

When the inverter module temperature reaches the setting range F7-69, multi-function terminal output ON signal.

F7-70	Output power correction coefficient	Range: 0.001 to 3.000	Default: 1.000
-------	-------------------------------------	-----------------------	----------------

Output power display = output power* F7-70 and it can be checked by monitor code U1-05.

F7-71	Linear speed display coefficient	Range: 0.000 to 60.000	Default: 1.000
-------	----------------------------------	------------------------	----------------

Linear speed =F7-71*sampling HDI pulse quantity per minute/Fb-07, and it can be checked by monitor code UI-14.

F7-72	Accumulative power consumption	Range: 0 to 65535	Default: measured value
-------	--------------------------------	-------------------	----------------------------

The accumulated power consumption so far can only be checked but not be modified.

F7-73	Performance software version	Range: 0.00~655.35	Default: ##
-------	------------------------------	--------------------	-------------

Performance software version number.

F7-74	Function software version	Range: 0.00~655.35	Default: ##
-------	---------------------------	--------------------	-------------

Function software version number.

F7-75	Improve function parameter display selecting	Range: 0~1	Default: 0
-------	--	------------	------------

0: Hide the improvements parameter group: H1~H3, L0~L5.

1: Display the improvements parameter group: H0~H3, L0~L5.

F7-76	Motor rotational display correction coefficient	Range: 0.0010~3.0000	Default: 1.000
-------	---	-------------------------	----------------

5.9 Group F8 Communication Parameter

F8-00	Baud rate setting	Range: 0~7	Default: 5
F8-01	Data format	Range: 0~3	Default: 0

Baud rate setting:

0: 300BPS

1: 600BPS

2: 1200BPS

3: 2400BPS

4: 4800BPS

5: 9600BPS

6: 19200BPS

7: 38400BPS

Baud rate is the data transfer rate between host machine and inverter. The bigger the baud rate, the faster the communication speed.

Data format:

0: No parity check: data format <8,N,2>

- 1: Even check: data format <8,E,1>
- 2: Odd check: data format <8,0,1>
- 3: No parity check 1: data format <8,N,1>

Caution : The setting baud rate and data format of the host machine should keep the same as those of the inverter. Otherwise, the communication can't be proceeded successfully.

F8-02	Communication address	Range: 0 to 247, 0 is broadcast address	Default: 1
-------	-----------------------	---	------------

When the local address is set as 0, thus it's broadcast address that can realize the function of host machine broadcast.

Caution: The local address is unique except broadcast, and it's the basic condition to realize point to point communication between host machine and inverter.

F8-03	Response delay	Range: 0ms to 30ms	Default: 2ms
-------	----------------	--------------------	--------------

Response delay means the interval time from the inverter end time of receiving data to start time of sending data to the host machine. If the response delay is less than the system processing time, then the response delay subjects to the time delay of the system processing time. If the response delay is more than the system processing time, after the system processes the data, it should be delayed to wait until the response delay time is up, then sending data to host machine.

F8-04	Communication timeout	Range: 0.0s to 30.0s	Default: 0.0s
-------	-----------------------	----------------------	---------------

When the function is set as 0.0 s, the communication overtime parameter is invalid. When the function is set as non-zero, if the internal time from one communication to next communication exceeds the communication timeout, the system will alarm communication fault (Err27). So generally it will be set invalid. If set the parameter in the continuous communication system, you can monitor the communication status.

F8-05	Communication data format selection	Range: 0~1	Default: 0
-------	-------------------------------------	------------	------------

0: Standard Modbus protocol

1: The returned bytes from the slave machine is one byte more than the standard Modbus protocol. Please refer to appendix A protocol description.

5.10 Group F9 Fault and Protection

F9-00	Motor overload protection selection.	Range: 0~1	Default: 1
-------	--------------------------------------	------------	------------

0: The inverter doesn't have overload protection function for the motor, and the motor has the risk of overheat damage. So it's suggested to change the heat relay between the inverter and the motor.

1: The inverter has overload protection function for the motor, and for the relationship of protection time and motor current please refer to Fig.5-20.

F9-01	Motor overload protection gain.	Range: 0.20 to 10.00	Default: 1.00
-------	---------------------------------	----------------------	---------------

In order to have valid protection for overloads of different motors, it need to set F9-01 properly and for method refers to overload protection curve as in Fig 5-20. In the figure L1 represent the relationship of motor protection time and motor current when F9-01=1. When the user need to change a certain current protection time, just need to change F9-01. The relationship

as below:

$$T = F9-01 \times T(L1)$$

For example: The user need to change the protection time of 150% rated current to 3 minutes. Firstly find out the corresponding protection time of 150% is 6 minutes from fig.5-20, so $F9-01 = \frac{\text{required protection time } T}{T(L1)} = \frac{3\text{minute}}{6\text{minutes}} = 0.5$.

The maximum time of overload protection is 100 minutes, while the minimum load time is 0.1 minute. The users can adjust it according to the actual need.

When the motor has overload, it will alarm Err14 to avoid damage caused by continuous overheat.

Note: There is no overload protection in default under 110% rated current. If it's needed to realize protection function of under 110% current, please properly set the overcurrent protection coefficient F9-35.

$$\text{Current percentage} = (\text{actual current} \div \text{rated current}) \times F9-35$$

For example: The user need to change the protection time of 90% rated current to 30.0 minutes. Firstly find out the corresponding current percentage of 30min is 130% from fig.5-20, $F9-35 = (130\% \div 90\%) \times 100\% = 144\%$. Pay attention that the maximum current protection percentage is 55%.

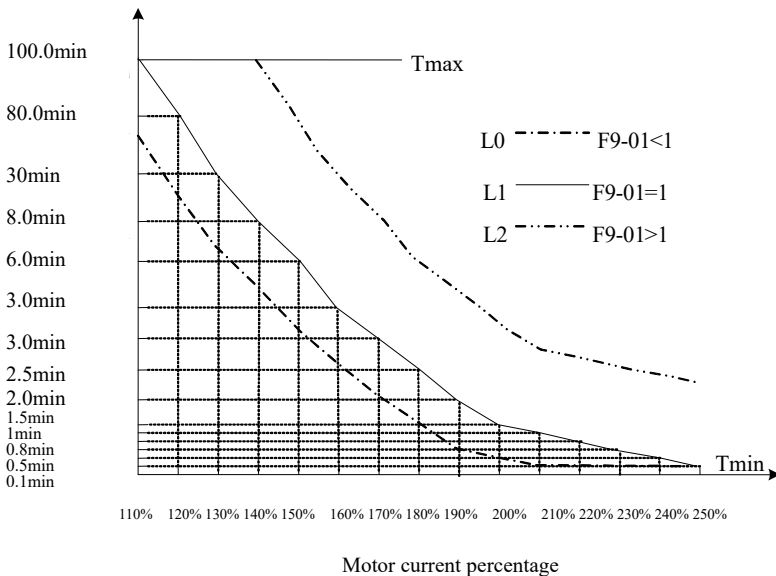

Fig.5-20 Motor overload protection curve

F9-02	Motor overload warning coefficient.	Range: 50% to 100%	Default: 80%
-------	-------------------------------------	--------------------	--------------

This function is used to give the system a warning signal before overload protection, so as to have a pre-protection to the motor. The bigger the value, the shorter the reserved time.

When the inverter output current accumulate until it's larger than the product between the set

overload protection time and F9-02, the multi-function digital output terminal choose “motor overload warning ON” switch signal. refer to explication(F6-00~F6-02) for setting function code when terminal function is 6.

F9-03	Over-voltage stall gain	Range: 0 to 100	Default: 30
F9-04	Over-voltage stall protective voltage	Range: 200.0V to 850.0V	Default: 760.0V<1>

<1> This value is 380V class default value, and 200V class corresponds to 380V default.

On the deceleration process, when the DC bus voltage is bigger than over-voltage protection voltage, the inverter will stop decelerating and keep still in present frequency, waiting until the bus voltage falling and then continue to decelerate.

Over-voltage stall gain is used to adjust the over-voltage restraining ability on decelerating process. The bigger the value, the stronger the over-voltage restraining. it's better to set this value as small as possible when there is no over-voltage.

For the load with small inertial, it's better to set the over-voltage stall a small value, otherwise it's easily to slow down the dynamic respond speed. For the load with large inertial, it's better to set the over-voltage stall a large value, otherwise the effect is not good so as to cause over-voltage fault.

When the over-voltage stall gain is set as 0, this function is cancelled.

F9-05	V/F over-current stall gain	Range: 0 to 100	Default: 20
F9-06	V/F over-current stall protective current	Range: 100% to 200%	Default: 150%
F9-07	VF weak magnetic current stall protection coefficient.	Range: 50% to 200%	Default: 100%

Over-current stall means when the output current reaches the setting over-current stall protection current (F9-06), the inverter stop accelerating on the acceleration process; decreasing the output frequency on constant speed running process; slow down the decelerating speed until the current less than over-current protection current (F9-06). For details please refer to fig.5-21.

Over-current stall protection current means the standard value for selecting over-current stall function. The inverter starts to conduct over-current stall protection function when the current exceeds this value. This value is a percentage that corresponding to rated current.

Over-current stall gain is used to adjust the ability of restraining the over-current. The bigger the value, the stronger the restraining ability. It's better to set the value as small as possible on the premise that there is no over-current.

For the load with small inertial, it's better to set the over-current stall gain a small value, otherwise it's easily to slow down the dynamic respond speed. For the load with large inertial, it's better to set the over-current stall gain a large value, otherwise the effect is not good so as to cause over-current fault. On the occasions that the inertial is very small, it's suggested to set the value less than 20.

When over-current stall gain is set as 0, this function is cancelled.

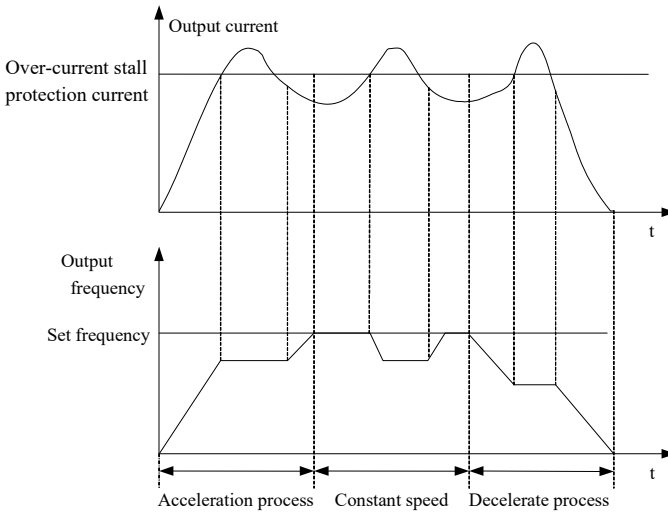

Fig.5-21 Over-current stall protection illustration

F9-08	Over-voltage stalling allowed to rise limit value	Range: 0.0% to 100.0%	Default: 10.0%
-------	---	-----------------------	----------------

It means the maximum frequency adjust value on over-voltage stall. Generally there is no need to modify.

F9-11	Fault auto reset times	Range: 0 to 20	Default: 0
F9-12	Fault relay action selection during fault auto reset	Range: 0~1	Default: 0

On the period after choosing inverter fault auto reset function, setting this parameter can decided whether the fault relay need to do action, so as to shielding the alarm and keep the machine running continuously.

F9-13	Time interval of fault auto reset	Range: 0.1s to 100.0s	Default: 1.0s
-------	-----------------------------------	-----------------------	---------------

It represent the waiting time from fault alarm to automatic reset.

F9-14	Input phase loss protection selection	Range: 0~1	Default: 1
-------	---------------------------------------	------------	------------

0: Prohibit

1: Enable, the fault code is Err23 when there is input phase loss.

F9-15	Output phase loss protection selection	Range: 0~1	Default: 1
-------	--	------------	------------

0: prohibit

1: Enable, the fault code is Err24 when there is output phase loss.

F9-16	Short-circuit to ground upon power-on	Range: 0~1	Default: 1
-------	---------------------------------------	------------	------------

0: prohibit

1: Enable, allow the inverter check if there is short circuit to ground. The fault code is Err20 if such fault happens.

F9-17	Under-voltage fault auto reset selection	Range: 0~1	Default: 0
-------	--	------------	------------

0: manual reset. After the under-voltage fault, though the bus voltage has recovered to normal, the fault is still existed. So it need manual reset for the under-voltage fault Err12.

1: automatic reset. After the under-voltage fault, the inverter follows the present bus voltage to clear the fault Err 12.

F9-18	Over-voltage inhibition mode selection	Range: 0~2	Default: 1
-------	--	------------	------------

0: invalid

1: Over-voltage inhibition mode 1. It's mainly used for avoiding overvoltage fault when bus voltage rising by energy feedback on deceleration process.

2: Over-voltage inhibition mode 1. It's mainly used on the occasions when bus voltage rising by load energy feedback on constant speed process which is caused by load centre skewing from the physical centre.

F9-19	Flux brake effective state selection	Range: 0~2	Default: 2
-------	--------------------------------------	------------	------------

0: invalid

1: valid on both constant speed or deceleration process.

2: only valid on deceleration process.

It's mainly used on the occasions which need fast stop. Flux brake makes the feedback energy caused by deceleration to consume on the motor, thus avoid the over-voltage fault. The restraining power can be adjusted by flux brake gain F2-10 (VF). When using brake resistance as over-voltage suppressor, please set F9-19 as 0 (invalid), otherwise it may have problem in deceleration process.

F9-20	Threshold of over-voltage inhibition mode 2	Range: 1.0% to 150.0%	Default: 100.0%
-------	---	-----------------------	-----------------

It means the adjustable limit value when over-voltage inhibition mode takes effective. The less the value, the less the rising amplitude of the bus voltage, so the deceleration time is much longer.

F9-22	Fault protection action selection 1	Range: 0~22202	Default: 0
-------	-------------------------------------	----------------	------------

Every setting digit has the same meaning as the unit digit.

Unit's place: motor overload – Err14

0: free stop

1: stop according to stop mode

2: keep running

Ten's digit: reserved

Hundred's place: input phase loss – Err23

Thousand's place: output phase loss – Err24

Myriabit's place: parameter read and write problem – Err25

F9-23	Fault protection action selection 2	Range: 0~22222	Default: 0
-------	-------------------------------------	----------------	------------

For meaning of every digit of fault protection action selection 2 please refer to fault protection action selection 1.

Unit's place: communication fault – Err27

0: free stop

1: stop according to stop mode

2: keep running

Ten's digit: exterior fault – Err28

Hundred's place: too large speed deviation fault – Err29

Thousand's place: user defined fault 1 – Err30

Myriabit's place: user defined fault 2 – Err31

F9-24	Fault protection action selection 3	Range: 0~22022	Default: 0
-------	-------------------------------------	----------------	------------

For meaning of every digit of fault protection action selection 3 please refer to fault protection action selection 1.

Unit's place: PID feedback loss on running – Err32

0: free stop

1: stop according to stop mode

2: keep running

Ten's digit: off load fault – Err34

Hundred's place: reserved

Thousand's place: present continuous running time arrival – Err39

Myriabit's place: accumulated running time arrival – Err40

Caution: For fault protection action selection 1 ~ Fault protection action selection 3, when choosing “free stop”, the inverter will display Err** then stop directly.

When choosing “stop according to stop mode”, the inverter will display Ala**, then stop according to stop mode. After stop it displays “Err**”.

When choosing “keep running”, the inverter will keep running and displays Ala**, and the running frequency is set by F9-26.

F9-26	Frequency selection for continuing to run upon fault	Range: 0~4	Default: 1
-------	--	------------	------------

0: Running with present running frequency

1: Running with the set frequency

2: Running with the upper limit frequency

3: Running with the lower limit frequency

4: Running with the standby frequency value F9-27

F9-27	Backup frequency upon abnormality	Range: 0.0% to 100.0%	Default: 100.0%
-------	-----------------------------------	-----------------------	-----------------

This value is the percentage corresponding to the maximum frequency, taking effective when F9-26 chooses abnormal standby frequency and problem happened.

F9-28	Protection upon load becoming 0	Range: 0~1	Default: 0
-------	---------------------------------	------------	------------

F9-29	Detection level of load becoming 0	Range: 0.0% to 80.0%	Default: 20.0%
F9-30	Detection time of load becoming 0	Range: 0.0s to 100.0s	Default: 5.0s

When off load protection is F9-28, if the output current is less than the off load detected value (9-29* rated current) set by F9-29, and the lasting time is more than the off load detected time, the inverter will output off load fault Err34. It also can choose the action status after off load by F9-24.

F9-31	Detection value of too large speed deviation	Range: 0.0% to 100.0%	Default: 20.0%
F9-32	Detection time of too large speed deviation	Range: 0.0s to 100.0s	Default: 0.0s

This function only takes effective on vector but not torque mode. 100% of F9-31 corresponds the maximum frequency F0-14.

When the inverter has detected the deviation between the actual speed and setting speed, speed deviation is larger than the too large speed deviation F9-31, and the lasting time is longer than detection time of too large speed deviation F9-32, the inverter will conduct Err29. Meanwhile it can use F9-23 to define the action status after the fault.

When the tool large speed deviation time is 0.0s, the too large speed protection is invalid.

F9-33	Over-speed detection value	Range: 0.0% to 100.0%	Default: 20.0%
F9-34	Over-speed detection time	Range: 0.0s to 100.0s	Default: 2.0s

This function is valid only on vector but not torque control mode. 100% of F9-34 corresponds the maximum frequency F0-14.

When the inverter has detected that the actual speed exceeds the maximum speed, and the excess value is larger than the over-speed detection value F9-33, and the lasting time is longer than the over-speed detection time F9-34, the inverter will conduct Err43.

When over-speed detection time is 0.0s, the over-speed protection is invalid.

F9-35	Motor overload protection current coefficient	Range: 100% to 200%	Default: 100%
-------	---	---------------------	---------------

This parameter is used to realize the over load protection on 110% rated current, and it needs to combine F9-00~F9-02 to use.

5.11 Group FA PID Function

PID control is a general method of process control. It adjusts the output frequency through proportional, integral and differential calculations of the difference between the feedback signal of the controlled quantity and the signal of the target quantity, and constitutes the closed-loop system so as to stabilize the controlled quantity at the target quality. It is applicable to such process control occasions with flow control, pressure control and temperature control. The basic principle framework of control is shown as follows:

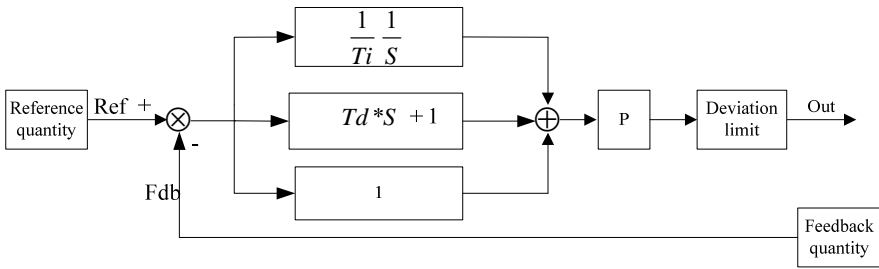

Fig.5-22 Process PID principle schematic diagram

FA-00	PID giving source	Range: 0~5	Default: 0
-------	-------------------	------------	------------

0: FA-01 setting

1: AI1

2: AI2

3: Communication giving

4: Pulse giving

5: Multi-segment command

6: Up/Down to revise the FA - 01 (when the F0-06 = 6 is effective)

When the frequency source selects PID, i.e. F0-06 or F0-07=6, this group of function is invalid.

This parameter decides the target quantity reference channel of the process PID.

The setup target quantity of the process PID is a relative value, and the setting range is 0~100%.

The PID range (FA-05) is not necessary because the system will always calculate according to the relative value (0 to 100%) no matter how the range is set. However, if PID range is set, it can view the actual values relative to the reference and feedback of PID via the display parameters on the keyboard.

FA-01	PID digital giving	Range: 0.0% to 100.0%	Default: 50.0%
-------	--------------------	-----------------------	----------------

When FA-00=0 is selected, the target source is keyboard giving. It needs to set this parameter.

FA-02	PID giving change time	Range: 0.00s to 650.00s	Default: 0.00s
-------	------------------------	-------------------------	----------------

PID giving changing time means the required time of PID changes from 0.0% to 100.0%.

When PID has changes, the actual value given by PID will not follow PID to change immediately, but to have lenear change according to the giving time.

FA-03	PID feedback source	Range: 0~7	Default: 0
-------	---------------------	------------	------------

0: AI1

1: AI2

2: AI1~AI2

3: Communication giving

4: PULSE giving

5: AI1+AI2

6: MAX(|AI1|,|AI2|)

7: MIN(|AI1|,|AI2|)

This parameter is used to choose process PID feedback signal channel. Feedback value of process PID is also a relative value, the setting range is 0.0% ~ 100.0%.

FA-04	PID action direction	Range: 0~1	Default: 0
-------	----------------------	------------	------------

0: Positive effect, when PID feedback signal is less than the giving value, the inverter output frequency will rise. The winding tension control is a example.

1: Negative effect, when PID feedback value is less than the giving value, the inverter output frequency will decrease. The unwinding tension control is a example.

Pay attention that this function is effected by multi-function terminal PID taking opposite direction.

FA-05	PID feedback range giving	Range: 0 to 65535	Default: 1000
-------	---------------------------	-------------------	---------------

PID giving feedback value is dimensionless unit, it used for displaying U1-10 of PID giving and U1-11 of PID feedback.

The relative value of PID feedback is 100.0%, corresponding to giving feedback range FA-05. For example, if set FA-05 as 4000, thus when PID gives 60.0%, PID giving display 2400 for U1-10.

FA-06	Proportional gain Kp1	Range: 0.0 to 100.0	Default: 20.0
FA-07	Integral time Ti1	Range: 0.01s to 10.00s	Default: 2.00s
FA-08	Differential time Td1	Range: 0.000s to 10.000s	Default: 0.000s

Proportional gain Kp1:

It decides the adjustment intensity of the whole PID regulator. The larger the Kp1, the stronger the adjustment intensity. Value 100.0 of this parameter indicates when the deviation between the PID feedback and the giving value is 100%, the adjustment amplitude of the PID regulator on the output frequency command is maximum frequency.

Integral time Ti1:

It decides the integral adjustment intensity of the PID regulator. The shorter the integral time, the stronger the adjust intensity. Integration time is the time within which the integration regulator performs continuous adjustment and the adjustment quantity reaches maximum frequency when the deviation between the PID feedback and the giving value is 100%.

Differential time Td1:

It decides the PID regulator intensity deviation changing rate. The longer the differential time, the stronger the adjusting intensity. Differential time is the time within which if the feedback quantity changes 100%, the adjustment quantity reaches maximum frequency.

FA-09	Cut-off frequency of PID reverse rotation	Range: 0.00Hz~max- frequency	Default: 0.00Hz
-------	---	------------------------------	-----------------

On some conditions, only when the PID output frequency is minus (means reverse running), can PID control the giving value and feedback value to the same status. But it's not allowed to use too large reverse frequency on some certain occasions, so FA-09 is used to define the upper limit of the reverse frequency.

FA-10	Deviation limit	Range: 0.0% to 100.0%	Default: 0.0%
-------	-----------------	-----------------------	---------------

When the deviation between PID giving value and feedback value is less than FA-10, PID stops adjusting. In this way, the output frequency keeps unchanged when the deviation between PID giving and feedback is small. It's effective in some closed loop control occasions.

FA-11	Differential limit	Range: 0.00% to 100.00%	Default: 0.10%
-------	--------------------	-------------------------	----------------

In PID regulator, differential effect is sensitive and it's easily to cause system oscillation. So generally PID differential is limited in a small range and FA-11 is used to define the output range of PID differential.

FA-12	PID feedback filter time	Range: 0.00s to 60.00s	Default: 0.00s
-------	--------------------------	------------------------	----------------

FA-12 is used to filter the PID feedback value. This kind of filtering is useful to decrease the distraction influence for the feedback value but will bring the respond character of closed-loop system.

FA-13	Detection value of PID feedback loss	Range: 0.0% to 100.0%	Default: 0.0s
FA-14	Detection time of PID feedback loss	Range: 0.0s to 3600.0s	Default: 3600.0s

This function is used to judge if PID feedback is lost. When the PID feedback value is less than the detection value of PID feedback loss FA-13, and the lasting time is longer than the detection time of PID feedback loss FA-14, the inverter conduct protection according to unit's digit selection of F9-24, then conducts fault ERR32 and alarm ALA32.

FA-18	Proportional gain Kip2	Range: 0.0 to 100.0	Default: 20.0
FA-19	Integral time Ti2	Range: 0.01s to 10.00s	Default: 2.00s
FA-20	Differential time Td2	Range: 0.000s to 10.000s	Default: 0.000s
FA-21	PID parameter switchover condition	Range: 0~2	Default: 0
FA-22	PID parameter switchover deviation 1	Range: 0.0% to FA-23	Default: 20.0%
FA-23	PID parameter switchover deviation 2	Range: FA-22 to 100.0%	Default: 80.0%

On some certain application occasions, one group of PID parameter can't meet the need of the whole system, so different PID parameters are needed to used on different occasions.

FA-21 is the switching condition of PID parameter, similar to Fa-06~FA-08.

FA-21=0: No switchover, use the first group of PID parameters.

FA-21=0: DI terminal switchover. Multi-function terminal function must be set as 43 (PID parameter switch terminal), when this terminal is invalid, it chooses parameter group 1 (FA-6~FA-8); when this terminal is valid, it chooses parameter group 2 (FA-18~FA-20).

FA-21=2: Automatic switchover according to deviation. When the absolute deviation between the giving value and the feedback value is less than PID parameter switch deviation 1 (FA-22), PID parameter chooses parameter group 1. When the absolute deviation between the giving value and the feedback value is more than PID parameter switch deviation 2 (FA-23), PID parameter chooses parameter group 2. When the deviation between the giving value and feedback value is in the range from deviation 1 to deviation 2, PID parameter is the Linear interpolation value of the two PID parameter lines. Please refer to fig.5-23.

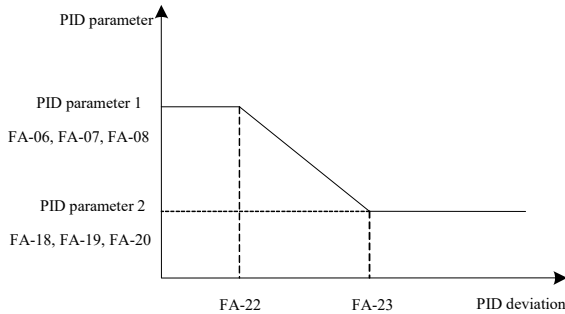

Fig.5-23 PID parameter switching

FA-24	PID parameter switchover deviation 2	Range: 0.0% to 100.0%	Default: 0.0%
FA-25	PID parameter switchover deviation 2	Range: 0.00s to 650.00s	Default: 0.00%

The PID output is fixed as the initial value FA-24 when the inverter starts. After keeping the initial value for time FA-25, PID starts the closed-loop adjustment calculation. Fig.5-24 illustrates the PID initial value function.

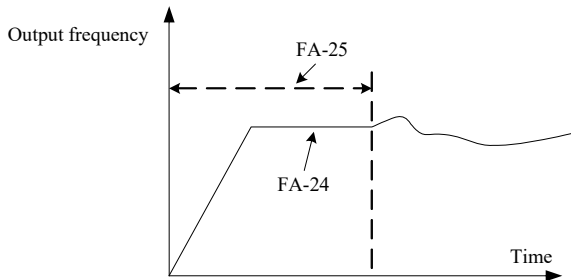

Fig.5-24 PID initial value function illustration

FA-26	Maximum deviation between two PID outputs in forward direction	Range: 0.00% to 100.00%	Default: 1.00%
FA-27	Maximum deviation between two PID outputs in reverse direction	Range: 0.00% to 100.00%	Default: 1.00%

This function is used to limit the difference value between two outputs of PID, so as to restrain the PID output to change too fast, thus the inverter can run steadily.

FA-28	PID integral property	Range: 00~11	Default: 00
-------	-----------------------	--------------	-------------

Unit's digit: integral separation selection

0: Invalid

1: Valid

If the set integral separation is valid, when multi-function digital DI integral pause (function 38) is valid, PID integral stops calculation and only the proportion and differential of PID is valid.

when the set integral separation is invalid, whether multi-function digital DI is valid or not, integral separation is invalid.

Ten's digit: whether to stop the integral when output value reaches the limit.

0: Continue the integral

1: Stop the integral

When PID output reaches the maximum value or minimum value, it can choose whether to stop integral function or not. If choose stop integral, the PID calculation stops. It can decrease the overshoot of PID.

FA-29	PID operation at stop	Range: 0~1	Default: 0
-------	-----------------------	------------	------------

0: PID doesn't calculate on stop status.

1: PID calculates on stop status.

5.12 Group Fb Swing Frequency and Fixed Length Count

The swing frequency function is applicable to the textile and chemical fiber fields and the applications where traversing and winding functions are required.

Swing frequency function means that the output frequency of the inverter swings up and down with the setup frequency around the center. The trace of running frequency at the time axis is shown in the figure below, of which the swing amplitude is set by Fb-00 and Fb-01. When FB-01 is set 0, the swing amplitude is 0, so the swing frequency is ineffective at the moment.

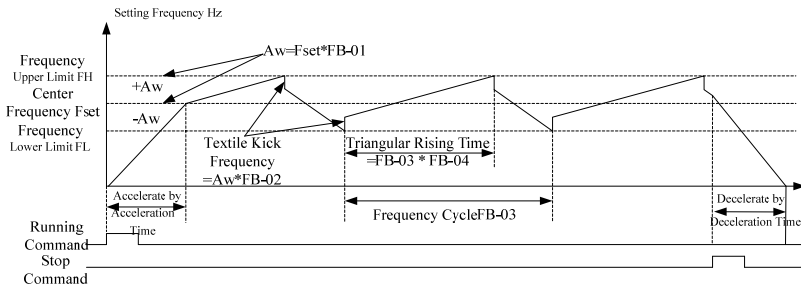

Fig.5-25 Swing Frequency Working Diagram

Fb-00	Swing frequency setting mode	Range: 0~1	Default: 0
-------	------------------------------	------------	------------

This parameter is used to decides the standard value of the amplitude.

0: Relative center frequency (F6-06 frequency source), and it's amplitude changing system. The amplitude is changing with the center frequency (set frequency).

1: Relative maximum frequency (F0-14), and it's fixed amplitude system, that means the amplitude will not change all the time.

Fb-01	Swing frequency amplitude	Range: 0.0% to 100.0%	Default: 0.0%
Fb-02	Jump frequency amplitude	Range: 0.0% to 50.0%	Default: 0.0%

This parameter is used to determine the values of swing amplitude and jump frequency.

When setting the amplitude which is relative to center frequency (Fb-00=0), amplitude $AW = \text{frequency source } F0-07 \times \text{swing amplitude } Fb-01$. When setting the amplitude which is relative to maximum frequency (Fb-00=1), $AW = \text{frequency source } F0-14 \times \text{swing amplitude } Fb-01$. When it running in swing frequency, jump frequency amplitude is equivalent to the frequency percentage of the jump frequency relative to swing amplitude, thus $\text{jump frequency} = \text{amplitude } AW \times \text{jump}$

frequency amplitude Fb-02. If choosing swing amplitude is relative to center frequency (Fb-00=0), jump amplitude is a changing value. If choosing swing amplitude is relative to maximum frequency (Fb-00=1), jump frequency is a fixed value.

Swing frequency is limited by the frequency upper limit and frequency lower limit.

Fb-03	Swing frequency cycle	Range: 0.1s to 3000.0s	Default: 10.0s
Fb-04	Triangular wave rising time coefficient	Range: 0.1% to 100.0%	Default: 50.0%

Swing frequency cycle: It refers to the time of a complete cycle of swing frequency.

Triangular wave rising time coefficient Fb-04, is the percentage of triangular wave rising time which relative to swing frequency cycle.

Triangular wave rising time= swing frequency cycle Fb-03×Triangular wave rising time coefficient Fb-04 (unit: s).

Triangular wave falling time =swing frequency cycle Fb-03 × (1-time constant of triangular wave boost Fb-04 (unit: s)

Fb-05	Set length	Range: 0m to 65535m	Default: 1000m
Fb-06	Actual length	Range: 0m to 65535m	Default: 0m
Fb-07	Pulse number per meter	Range: 0.1 to 6553.5	Default: 100.0

The above function codes are used for fixed length control.

Length information is collected by multi-function digital input terminals. The collected pulse quantity divides by pulse number per meter Fb-07, the result can be the actual length Fb-06. When the actual length is greater or equal to the set length Fb-05, multi-function digital terminal output “length reached” ON signal.

During the fixed length control process, it can conduct the length reset action (DI function select 31) by multi-function terminals. For details please refer to setting of F5-00~F5-04.

It needs to set the relevant terminal as “length count input” (DI function select 31), and must use HDI ports when the frequency is high.

Fb-08	Set count value	Range: 1 to 65535	Default: 1000
Fb-09	Designated count value	Range: 1 to 65535	Default: 1000

The count value need to be collected by multi-function digital input terminals. It need to set the relevant input terminals to “counter input” (function 28) and must use DI5 port when the frequency is high.

When the count value reaches the set count value Fb-08, multi-function digital terminal output “set count value reached” ON signal.

When the count value reaches the specified count value Fb-09, multi-function digital terminal output “specified count value reached” ON signal.

The specified count valueFb-09 should not greater than the set count value Fb-08. For more details please refer to Fig.5-26.

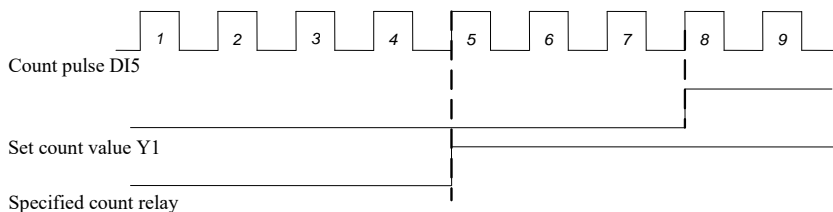

Fig.5-26 Set count value giving and specified count value giving illustration

5.13 Group FC Multi-segment Command and Simple PLC Function

Simply PLC function is a built-in PLC for automatic control of the multi-segment logic. It can set the running time, direction and frequency to satisfy the production need.

SSI3300 series of smart inverter can implement 16-segment variable control, and has four types of acceleration/deceleration time for selection

When the setup PLC completes one cycle, it can output one ON signal through the multi-function output terminal Y1 and multi-function RELAY1. All the details shown as F6-00~F6-02

FC-00	Multi-segment command 0	Range: -100.0% to 100.0%	Default: 0.0%
FC-01	Multi-segment command 1	Range: -100.0% to 100.0%	Default: 0.0%
FC-02	Multi-segment command 2	Range: -100.0% to 100.0%	Default: 0.0%
FC-03	Multi-segment command 3	Range: -100.0% to 100.0%	Default: 0.0%
FC-04	Multi-segment command 4	Range: -100.0% to 100.0%	Default: 0.0%
FC-05	Multi-segment command 5	Range: -100.0% to 100.0%	Default: 0.0%
FC-06	Multi-segment command 6	Range: -100.0% to 100.0%	Default: 0.0%
FC-07	Multi-segment command 7	Range: -100.0% to 100.0%	Default: 0.0%
FC-08	Multi-segment command 8	Range: -100.0% to 100.0%	Default: 0.0%
FC-09	Multi-segment command 9	Range: -100.0% to 100.0%	Default: 0.0%
FC-10	Multi-segment command 10	Range: -100.0% to 100.0%	Default: 0.0%
FC-11	Multi-segment command 11	Range: -100.0% to 100.0%	Default: 0.0%
FC-12	Multi-segment command 12	Range: -100.0% to 100.0%	Default: 0.0%
FC-13	Multi-segment command 13	Range: -100.0% to 100.0%	Default: 0.0%
FC-14	Multi-segment command 14	Range: -100.0% to 100.0%	Default: 0.0%
FC-15	Multi-segment command 15	Range: -100.0% to 100.0%	Default: 0.0%

When frequency source chooses F0-06, F0-07, F0-10 as multi-segment speed mode, it need to set FC-00~FC-15 to fix the characters.

Note: Symbol of FC-00~FC-15 decides the direction of simple PLC. Negative symbol means running in reverse. Please refer to below diagram.

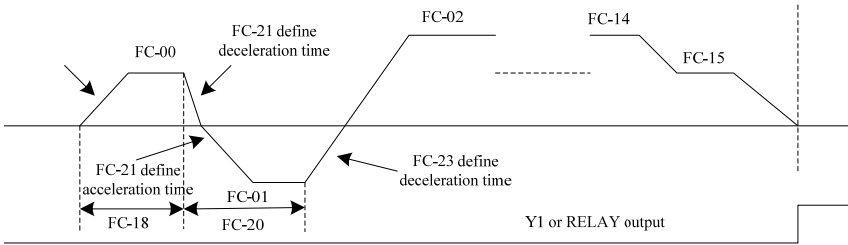

Fig.5-27 simple PLC illustration

FC-16	Simple PLC running mode	Range: 0~2	Default: 0
-------	-------------------------	------------	------------

Simple PLC has two functions: Act as frequency source or VF separation voltage.

Fig.5-28 is the illustration that simple PLC acts as frequency source with which the symbol of FC-00~FC-15 decide the running direction, the inverter runs in reverse if it's negative symbol.

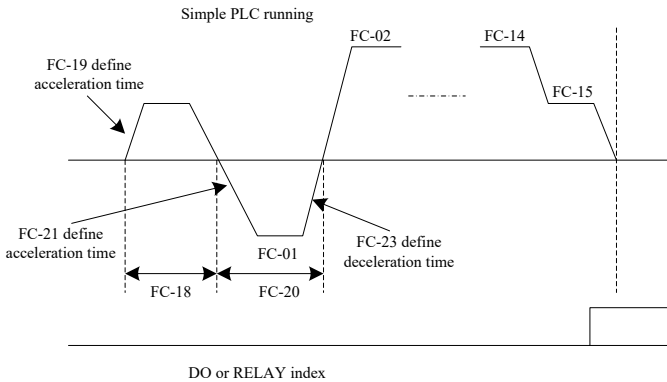

Fig.5-28 Simple PLC illustration

When it used as frequency source, PLC has three kinds of running ways.

0: Stop after running in single time.

The inverter stops automatically after finishing a single cycle, and need running command to restart it.

1: Keep the final value after the single running end.

After the inverter finishing a single circle, keep the final frequency and direction of the last period of running automatically.

2: Keep running gall the time.

After the inverter finishing one cycle, it will start another cycle automatically until stop command put in.

FC-17	Simple PLC retentive selection	Range: 0~3	Default: 0
-------	--------------------------------	------------	------------

This function defines the power off memory way at stop on PLC running process.

0: No memory on both power-off and stop.

1: With memory on power-off but no memory on stop.

2: No memory on power-off but with memory on stop.

3: With memory on both power-off and stop.

PLC power-off memory means memorizing the running stage and frequency on PLC process before power-off. The next time to have power on, it continues running from the memory stage. If choose no memory, it will start the PLC process from the beginning every time power on to start.

PLC stop memory means memorizing the running stage and frequency on PLC process before stop. The next time to restart, it continues running from the memory stage. If choose no memory, it will start the PLC process from the beginning every time restart it.

FC-18	Running time of simple PLC reference 0	Range: 0.0~6500.0	Default: 0.0
FC-19	Acceleration/deceleration time of simple PLC reference 0	Range: 0~3	Default: 0
FC-20	Running time of simple PLC reference 1	Range: 0.0~6500.0	Default: 0.0
FC-21	Acceleration/deceleration time of simple PLC reference 1	Range: 0~3	Default: 0
FC-22	Running time of simple PLC reference 2	Range: 0.0~6500.0	Default: 0.0
FC-23	Acceleration/deceleration time of simple PLC reference 2	Range: 0~3	Default: 0
FC-24	Running time of simple PLC reference 3	Range: 0.0~6500.0	Default: 0.0
FC-25	Acceleration/deceleration time of simple PLC reference 3	Range: 0~3	Default: 0
FC-26	Running time of simple PLC reference 4	Range: 0.0~6500.0	Default: 0.0
FC-27	Acceleration/deceleration time of simple PLC reference 4	Range: 0~3	Default: 0
FC-28	Running time of simple PLC reference 5	Range: 0.0~6500.0	Default: 0.0
FC-29	Acceleration/deceleration time of simple PLC reference 5	Range: 0~3	Default: 0
FC-30	Running time of simple PLC reference 6	Range: 0.0~6500.0	Default: 0.0
FC-31	Acceleration/deceleration time of simple PLC reference 6	Range: 0~3	Default: 0
FC-32	Running time of simple PLC reference 7	Range: 0.0~6500.0	Default: 0.0
FC-33	Acceleration/deceleration time of simple PLC reference 7	Range: 0~3	Default: 0
FC-34	Running time of simple PLC reference 8	Range: 0.0~6500.0	Default: 0.0
FC-35	Acceleration/deceleration time of simple PLC reference 8	Range: 0~3	Default: 0
FC-36	Running time of simple PLC reference 9	Range: 0.0~6500.0	Default: 0.0
FC-37	Acceleration/deceleration time of simple PLC reference 9	Range: 0~3	Default: 0
FC-38	Running time of simple PLC reference 10	Range: 0.0~6500.0	Default: 0.0
FC-39	Acceleration/deceleration time of simple PLC reference 10	Range: 0~3	Default: 0
FC-40	Running time of simple PLC reference 11	Range: 0.0~6500.0	Default: 0.0

FC-41	Acceleration/deceleration time of simple PLC reference 11	Range: 0~3	Default: 0
FC-42	Running time of simple PLC reference 12	Range: 0.0~6500.0	Default: 0.0
FC-43	Acceleration/deceleration time of simple PLC reference 12	Range: 0~3	Default: 0
FC-44	Running time of simple PLC reference 13	Range: 0.0~6500.0	Default: 0.0
FC-45	Acceleration/deceleration time of simple PLC reference 13	Range: 0~3	Default: 0
FC-46	Running time of simple PLC reference 14	Range: 0.0~6500.0	Default: 0.0
FC-47	Acceleration/deceleration time of simple PLC reference 14	Range: 0~3	Default: 0
FC-48	Running time of simple PLC reference 15	Range: 0.0~6500.0	Default: 0.0
FC-49	Acceleration/deceleration time of simple PLC reference 15	Range: 0~3	Default: 0
FC-50	Time unit of simple PLC	Range: 0~1	Default: 0

They are used to define every running time and acceleration/ deceleration selection. Among them acceleration/ deceleration selection 0~3 respectively represent acceleration/ deceleration time 0: F0-23, F0-24; acceleration/ deceleration time 1: F7-03, F7-04; acceleration/ deceleration time 2: F7-05, F7-06; acceleration/ deceleration time 3: F7-07, F7-08.

FC-50 defined the running time unit of every PLC.

0: Second

1: Hour

FC-51	MS priority selection	Range: 0~1	Default: 1
-------	-----------------------	------------	------------

Multi speed priority means when not all the multi speed terminal is 0, give priority to conduct the multi speed command value.

0: No multi speed priority

1: Multi speed priority

FC-52	Acceleration/deceleration time of multi-segment speed	Range: 0~3	Default: 0
-------	---	------------	------------

Under the circumstance of multi speed priority, conduct acceleration/ deceleration selection. 0~3 respectively represent acceleration/ deceleration 1~4.

FC-53	FC - 00 - FC - 15 units selection of multi-segment speed	Range: 0~1	Default: 0
-------	--	------------	------------

It is used to select the units of FC - 00 - FC - 15 multi-segment speed, in order to meet the needs of different occasions to multistage speed frequency unit

0:%

1:Hz

FC-55	Multi-segment command 0 giving	Range: 0~5	Default: 0
-------	--------------------------------	------------	------------

This parameter decides the giving channels of multi command. Multi command 0 not only can choose FC-00, but also can choose many other options for the convenience to switch between multi command and other giving ways. When multi command or simple PLC acts as frequency

source, both of them can switch between two kinds of frequency source.

- 0: Function code FC-00 giving
- 1: AI1 giving
- 2: AI2 giving
- 3: PULSE
- 4: PID
- 5: Preset frequency giving (F0-11), UP/DOWN revisable.

5.14 Group Fd Torque Control Parameter

Only when F0-3 is vector control can it conduct torque control, thus control the motor output torque by torque command. Pay attention to below items when using torque control:

Torque control take effect

If it's needed to make torque control take effect, please set Fd-10 to 1, or set multi-function DI terminal function to 44. Besides, it also can realize torque control prohibited (function 32) through multi-function digital DI terminals. When torque prohibited function is effective, the inverter is fixed with speed control mode.

Torque command and speed limitation setting

Torque control can be set by Fd-00 and Fd-01, when torque source is non-digital setting, 100% input corresponds to Fd-01 value.

Speed limitation can be set by Fd-03 and Fd-04, or through upper limit frequency F0-15, F0-16 and F0-17.

Torque command direction setting

When it's torque control, torque command is relevant to running command and torque value like below form:

Running command	Input torque value	Torque command direction
Forward	> 0	Forward direction
Forward	< 0	Reverse direction
Reverse	> 0	Reverse direction
Reverse	< 0	Forward direction

Switchover between speed and torque mode

When multi function digital DI terminal set the switchover (function 44) between speed control/ torque control, when the corresponding terminal function is effective, control mode is equivalent to Fd-10 value opposite; on the contrary control mode is determined by Fd-10.

Fd-00	Torque command source selection	Range: 0~6	Default: 0
-------	---------------------------------	------------	------------

Fd-00 is used to set the torque source, totally have 7 kinds of setting mode.

0: Digital setting (Fd-01), target torque use Fd-01 setting value directly.

1: AI1

2: AI2

Target torque is determined by analog value. SSI3300 control board has 2 analog input terminals (AI1,AI2). AI1 is 0V~10V voltage type input; AI2 can be 0V~10V voltage type input, or 0mA~20mA current input, which in selected by the switch on control board.

Relationship curve of AI1, AI2 input voltage and target torque can be selected by F5-45. SSI3300 has 4 groups of corresponding curve, in which 2 groups are two-point straight lines, 2 groups are four-point arbitrary curves. Users can set them by function code F5-15~F5-23 and group FE function code. Function code F5-45 is used to set AI1~AI2 analog input, respectively choosing two groups of curves of the 4 curves group.

When AI is used for torque giving, 100.0% of voltage/ current input setting, means the percentage correspond torque digital setting FD-01.

3: Communication giving

It means target torque is given by communication mode. The data is given by upper machine communication address 0x1000, data format is -100.00%~100.00%, 100.00% means the percentage corresponds to FD-01.

4. PULSE (HDI)

Target torque is given by terminal HDI high speed pulse.

Pulse giving signal specification: voltage range 9V~30V, frequency range 0kHz~ 50kHz. Pulse giving can only be input by HDI terminal.

HDI terminal input pulse frequency and the setting relationship can be set by F5-30~ F5-34, this relationship is two-point straight line. 100.0% of pulse input means the percentage correspond to torque digital setting FD-01.

5. MIN (AI1,AI2)

It means the target torque is given by the minimum value between AI1 and AI2.

6: MAX (AI1,AI2)

It means the target torque is given by the maximum value between AI1 and AI2.

The full range of 1~6 corresponds to Fd-01.

Fd-01	Torque digital giving	Range: -200.0% to 200.0%	Default: 150.0%
-------	-----------------------	--------------------------	-----------------

Torque setting uses relative value, 100.0% corresponds to motor rated torque. Setting range -200% ~ 200%, means that the maximum torque of inverter is equivalent to 2 times of rated torque. When motor power is more than inverter power, it will be limited in the maximum torque.

Fd-03	Forward maximum frequency of torque control	Range: 0.00Hz ~ F0-14	Default: 50.00Hz
Fd-04	Reverse maximum frequency of torque control	Range: 0.00Hz ~ F0-14	Default: 50.00Hz

They are used to set the forward or reverse maximum running frequency on the torque control mode.

On the torque control mode, the motor rotation speed will continuously rising if the load torque is less than the motor output torque. In order to avoid accident like galloping, it must limit the maximum speed of the motor.

Fd-06	Torque setting filter time	Range: 0.00s to 10.00s	Default: 0.00s
-------	----------------------------	------------------------	----------------

Setting this parameter can get a smoother and more gentle torque command, but the respond will be slower.

Fd-07	Acceleration time in torque control	Range: 0.0s to 1000.0s	Default: 10.0s
-------	-------------------------------------	------------------------	----------------

Fd-08	Deceleration time in torque control	Range: 0.0s to 1000.0s	Default: 10.0s
-------	-------------------------------------	------------------------	----------------

This parameter is used to set the acceleration/ deceleration time of the maximum frequency to decrease the start impact when setting torque control.

Fd-10	Speed/Torque control selection	Range: 0~1	Default: 0
-------	--------------------------------	------------	------------

0: Speed mode

1: Torque mode

5.15 Group FE AI Multi-point Curve Setting

FE-00	AI curve 1 minimum input	Range: -10.00V to FE-02	Default: 0.00V
FE-01	Corresponding setting of AI curve 1 minimum input	Range:- 100.0% to 100.0%	Default: 0.0%
FE-02	AI curve 1 inflexion 1 input	Range: FE-00 to FE-04	Default: 3.00V
FE-03	Corresponding setting of AI curve 1 inflexion 1 input	Range: -100.0% to 100.0%	Default: 30.0%
FE-04	AI curve 1 inflexion 2 input	Range: FE-02to FE-06	Default: 6.00V
FE-05	Corresponding setting of AI curve 1 inflexion 2 input	Range: -100.0% to 100.0%	Default: 60.0%
FE-06	AI curve 1 maximum input	Range: FE-06 to 10.00V	Default: 10.00V
FE-07	Corresponding setting of AI curve 1 maximum input	Range: -100.0% to 100.0%	Default: 100.0%
FE-08	AI curve 2 minimum input	Range: -10.00V to FE-02	Default: 0.00V
FE-09	Corresponding setting of AI curve 2 minimum input	Range: -100.0% to 100.0%	Default: 0.0%
FE-10	AI curve 2 inflexion 1 input	Range: FE-00 to FE-04	Default: 3.00V
FE-11	Corresponding setting of AI curve 2 inflexion 1 input	Range: -100.0% to 100.0%	Default: 30.0%
FE-12	AI curve 2 inflexion 2 input	Range: FE-02to FE-06	Default: 6.00V
FE-13	Corresponding setting of AI curve 2 inflexion 2 input	Range: -100.0% to 100.0%	Default: 60.0%
FE-14	AI curve 2 maximum input	Range: FE-06 to 10.00V	Default: 10.00V
FE-15	Corresponding setting of AI curve 2 maximum input	Range: -100.0% to 100.0%	Default: 100.0%

The above function code define the setting value relationship between analog input voltage and analog input value. When analog input voltage exceeds the set maximum or minimum range, the exceed part will be calculated as maximum or minimum value.

When analog input is current input, 1mA is equivalent to 0.5V.

Curve 1 and curve 2 are in accordance with analog value group F5 quantization. While group F5 is quantified to straight line but group FE can be set to curve type, so it's more flexible for analog to input multi-point curves. Please refer to below diagram.

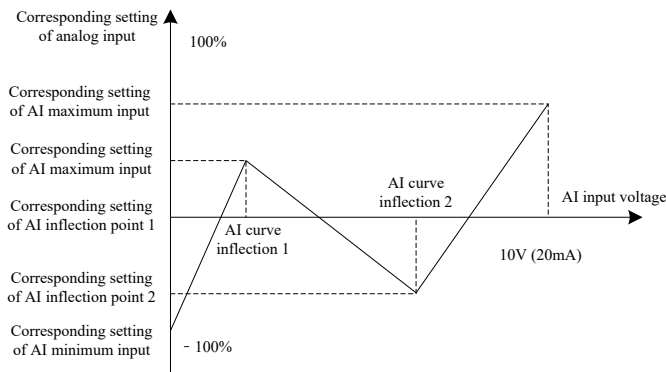

Fig.5-29 Multi-point corresponding illustration

FE-24	Jump point of AI1 setting	Range: -100.0% to 100.0%	Default: 0.0%
FE-25	Jump amplitude of AI1 setting	Range: 0.0% to 100.0%	Default: 0.5%
FE-24	Jump point of AI2 setting	Range: -100.0% to 100.0%	Default: 0.0%
FE-25	Jump amplitude of AI2 setting	Range: 0.0% to 100.0%	Default: 0.5%

Analog input AI1~AI2 of SSI3300 all have the value jump function.

Jump function means when analog value changing around the jump point range, set the analog value as jump point value.

Example: Voltage of analog input AI1 is fluctuated around 5V, the fluctuation range is 4.90V~5.10V, AI minimum input 0.00V corresponds to 0.0%, while maximum input 10.0V corresponds to 100.0%, so the detected AI1 corresponding setting is fluctuated between 49.0%~ 51.0%. If setting AI1 jump point FE-24 as 50.0%, setting AI1 jump amplitude FE-25 as 1.0%, AI1 has been transformed to a stable input and the fluctuation is eliminated.

5.16 Group FF Default Parameter

It's the factory set parameter group, users can't modify it.

5.17 Group H0 Second Motor Parameter Setting

When users need to switch between 2 motors, it can realize the function by H0-00 or NO.41 function of multi function digital DI terminal. Besides, the 2 motors can respectively set the nameplate parameter, motor tuning, VF control or vector control, and separately set the relevant parameters to VF control or vector control.

Three groups of function code (H1, H2, H3) respectively correspond to motor parameter, VF parameter setting, vector control parameters of the second motor. All the parameters of group H, both the definition and usage are same as those of the first motor, so users can refer to relevant parameters of motor 1.

H0-00	Motor selection	Range: 1~2	Default: 1
-------	-----------------	------------	------------

1: NO.1 motor

2: NO.2 motor

If the present motor is NO.1 motor, H1~H3 function groups are invisible.

H0-01	Motor 2 control mode	Range: 1~2	Default: 2
-------	----------------------	------------	------------

1: Open loop vector control (speed sensorless vector control)

2: VF control

H0-02	Motor 2 acceleration/deceleration time	Range: 0~4	Default: 0
-------	--	------------	------------

0: Same as the first motor

1: Acceleration/ deceleration time 1, F0-23, F0-24

2: Acceleration/ deceleration time 2, F7-03, F7-04

3: Acceleration/ deceleration time 2, F7-05, F7-06

4: Acceleration/ deceleration time 4, F7-07, F7-08

5.18 Group H1 Second Motor Parameter

This group of function code parameter description is same as group F4.

H1-00	Auto-tuning selection	Range: 0~2	Default: 0
-------	-----------------------	------------	------------

0: No function

1: Static tuning

2: Dynamic complete tuning

H1-01	Motor 2 rated power	Range: 0.4kW to 1000.0kW	Default: Model dependent
H1-02	Motor 2 rated voltage	Range: 0V to 1500V	Default: 380V
H1-03	Motor 2 poles number	Range: 2 to 64	Default: Model dependent
H1-04	Motor 2 rated current	Range: 0.1A~3000.0A	Default: Model dependent
H1-05	Motor 2 rated frequency	Range: 0.00Hz to F0-14	Default: 50.00Hz
H1-06	Motor 2 rated rotation speed	Range: 0rpm to 60000rpm	Default: Model dependent
H1-07	Motor 2 no-load current	Range: 0.1A~1500.0A	Default: Model dependent
H1-08	Motor 2 stator resistance	Range: 0.001Ωto 65.535Ω	Default: Model dependent
H1-09	Motor 2 rotor resistance	Range: 0.001Ωto 65.535Ω	Default: Model dependent
H1-10	Motor 2 mutual inductive	Range: 0.1mH to 6553.5mH	Default: Model dependent
H1-11	Motor 2 leakage inductive	Range: 0.01mH to 655.35mH	Default: Model dependent
H1-12	Acceleration time of complete	Range: 1.0s to 600.0s	Default: 10.0s

	auto-tuning		
H1-13	Deceleration time of complete auto-tuning	Range: 1.0s to 600.0s	Default: 10.0s

5.19 Group H2 Second Motor VF Curve Setting

This group of function code detail description is same as group F2. For the VF control codes that are not listed in this group, please use group F2 directly.

H2-00	Torque boost	Range: 0.0% ~ 30.0%	Default: 0.0%
-------	--------------	---------------------	---------------

When this parameter is set to 0, it means torque boost automatically.

H2-02	Oscillation suppression gain	Range: 0 to 100	Default: Model dependent
-------	------------------------------	-----------------	--------------------------

5.20 Group H3 Second Motor Vector Control Parameter

This group of parameters are similar to group F3, which is effective only on the second motor. For details description please refer to group F3.

H3-00	Switchover frequency 1	Range: 1.00Hz to H3-02	Default: 5.00 Hz
H3-02	Switchover frequency 2	Range: H3-00 to F0-14	Default: 10.00Hz
H3-04	Speed loop proportional gain at low frequency	Range: 0.1 to 10.0	Default: 4.0
H3-05	Speed loop integral time at low frequency	Range: 0.01s to 10.00s	Default: 0.50s
H3-06	Speed loop proportional gain at high frequency	Range: 0.1 to 10.0	Default: 2.0
H3-07	Speed loop integral time at high frequency	Range: 0.01s to 10.00s	Default: 1.00s
H3-08	Speed loop integral property	Range: 0 ~1	Default: 0
H3-11	Torque adjustment proportional gain Kp	Range: 0 to 30000	Default: 2000
H3-12	Torque adjustment integral gain Ki	Range: 0 to 30000	Default: 1300
H3-13	Excitation adjustment proportional gain Kp	Range: 0 to 30000	Default: 2000
H3-14	Excitation adjustment integral gain Ki	Range: 0 to 30000	Default: 1300
H3-15	Flux braking gain	Range: 0 to 200	Default: 0
H3-16	Field weakening torque correction ratio	Range: 50% to 200%	Default: 100%
H3-17	Slip compensation gain	Range: 50% to 200%	Default: 100%
H3-18	Speed loop feedback filter time	Range: 0.000s to 1.000s	Default: 0.015s
H3-19	Speed loop output filter time	Range: 0.000s to 1.000s	Default: 0.000s

H3-20	Source of power-driven torque upper limit	Range: 0 to 4	Default: 0
H3-21	Power-driven torque upper limit	Range: 0.0% to 200.0%	Default: 150.0%
H3-22	Source of braking torque upper limit	Range: 0 to 4	Default: 0
H3-23	Braking torque upper limit	Range: 0.0% to 200.0%	Default: 150.0%

5.21 Group L0 System Parameter

L0 is used to manage the inverter function code group, users can set it according to the actual need.

L0-00	Parameters only for reading	Range: 0 ~ 1	Default: 1
-------	-----------------------------	--------------	------------

0: Ineffective

1: Except L0-00, all the function code can only read, but can't be modified. It can avoid the mis-operation to the parameters.

L0-01	LCD Top menu display	Range: 0 ~ 5	Default: 0
-------	----------------------	--------------	------------

It is used to select the second display variables of LCD top menu on running, and first display variable is the operating frequency and cannot be changed.

0: output current

1: motor rotation speed

2: load speed

3: output voltage

4: PID giving

5: PID feedback

L0-02	LCD language selection	Range: 0 ~ 1	Default: 0
-------	------------------------	--------------	------------

0: Chinese

1: English

L0-03	LED menu switch selection	Range: 0 ~ 1	Default: 0
-------	---------------------------	--------------	------------

0: prohibition

1: enable

L0-04	Vector running frequency display selection	Range: 0 ~ 1	Default: 0
-------	--	--------------	------------

0: Real-time frequency

1: setting frequency

L0-05	UP/Down regulation display selection	Range: 0 ~ 1	Default: 0
-------	--------------------------------------	--------------	------------

0: Display the setting value

1: Display the current variable value

5.22 Group L1 User Function Code Customization

SSI3300 series of inverter provide 31 customized function code, for the user's convenience to read, modify and shortcut operations. After customizing the function code by group L1, it can

check and modify the function code by entering the user menu mode –USEr. How to enter or quit the user menu mode please refer to chapter 4 (4.4 Function code menu mode and switchover description).

L1-00	Clear user-defined parameters	Range: 0 ~ 1	Default: 0
-------	-------------------------------	--------------	------------

0: Ineffective

1: Clear the customized function code. After clearing L1-01~L1-31 are all uF0-00, meanwhile, it can use F0-28 to recover the default function codes.

L1-01	User-defined parameter 1	Range: uF0-00 to uU1-xx	Default: uF0-03
L1-02	User-defined parameter 2	Range: Same as L1-01	Default: uF0-04
L1-03	User-defined parameter 3	Range: Same as L1-01	Default: uF0-06
L1-04	User-defined parameter 4	Range: Same as L1-01	Default: uF0-23
L1-05	User-defined parameter 5	Range: Same as L1-01	Default: uF0-24
L1-06	User-defined parameter 6	Range: Same as L1-01	Default: uF4-00
L1-07	User-defined parameter 7	Range: Same as L1-01	Default: uF4-01
L1-08	User-defined parameter 8	Range: Same as L1-01	Default: uF4-02
L1-09	User-defined parameter 9	Range: Same as L1-01	Default: uF4-04
L1-10	User-defined parameter 10	Range: Same as L1-01	Default: uF4-05
L1-11	User-defined parameter 11	Range: Same as L1-01	Default: uF4-06
L1-12	User-defined parameter 12	Range: Same as L1-01	Default: uF4-12
L1-13	User-defined parameter 13	Range: Same as L1-01	Default: uF4-13
L1-14	User-defined parameter 14	Range: Same as L1-01	Default: uF5-00
L1-15	User-defined parameter 15	Range: Same as L1-01	Default: uF5-01
L1-16	User-defined parameter 16	Range: Same as L1-01	Default: uF5-02
L1-17	User-defined parameter 17	Range: Same as L1-01	Default: uF6-00
L1-18	User-defined parameter 18	Range: Same as L1-01	Default: uF6-01
L1-19	User-defined parameter 19	Range: Same as L1-01	Default: uF0-00
L1-20	User-defined parameter 20	Range: Same as L1-01	Default: uF0-00
L1-21	User-defined parameter 21	Range: Same as L1-01	Default: uF0-00
L1-22	User-defined parameter 22	Range: Same as L1-01	Default: uF0-00
L1-21	User-defined parameter 23	Range: Same as L1-01	Default: uF0-00
L1-22	User-defined parameter 24	Range: Same as L1-01	Default: uF0-00
L1-23	User-defined parameter 25	Range: Same as L1-01	Default: uF0-00
L1-24	User-defined parameter 26	Range: Same as L1-01	Default: uF0-00
L1-25	User-defined parameter 27	Range: Same as L1-01	Default: uF0-00
L1-26	User-defined parameter 28	Range: Same as L1-01	Default: uF0-00
L1-27	User-defined parameter 29	Range: Same as L1-01	Default: uF0-00
L1-28	User-defined parameter 30	Range: Same as L1-01	Default: uF0-00
L1-29	User-defined parameter 31	Range: Same as L1-01	Default: uF0-00

The initial letter u of customized function range represents customized function code, and the rest of them represent function code.

Example: uF0-03 means customized function code is F0-03, but uF0-00 means that customized function code is empty.

5.23 Group L2 Optimizing Control Parameter

L2-00	Dead zone compensation selection	Range: 0 ~ 1	Default: 1
-------	----------------------------------	--------------	------------

0: Without compensation

1: With compensation

L2-01	PWM modulation mode	Range: 0 ~ 1	Default: 0
-------	---------------------	--------------	------------

0: Asynchronous modulation

1: Synchronous modulation. It's effective only on VF control mode and the running frequency must be more than 85Hz.

Synchronous modulation means the inverter carrier wave frequency is linear changing with the output frequency, generally used in occasions with high frequency and it's beneficial to improve the quality of output voltage. While asynchronous modulation has better effect when carrier wave frequency is constant, generally used in occasions with low frequency.

L2-02	PWM seven phase/five phase selection	Range: 0 ~ 1	Default: 0
-------	--------------------------------------	--------------	------------

0: it has 7 segments on the whole process.

1: Automatically switchover between 7 segments or 5 segments.

The inverter switching loss is big under the PWM 7 segments continuous modulation, but the ripple current is smaller; while the inverter switching loss is small under 5 segments modulation, but the ripple current is bigger and the motor noise is increasing.

L2-03	CBC current limit	Range: 0 ~ 1	Default: 1
-------	-------------------	--------------	------------

0: Prohibited

1: Enable, it can decrease the overcurrent fault of the inverter in a greater degree, thus keeps running uninterrupted. If the inverter is in fast current limit for a long time, it will conduct Err33, indicating that the inverter is overload and needs to stop.

L2-04	Braking threshold	Range: 350.0V to 780.0V	Default: 690.0V<1>
-------	-------------------	-------------------------	--------------------

<1> means the value of 380Vclass inverter, and when in 200V class this value is 360.0V.

This value is brake resistance startup point. If there exists brake resistance and the bus voltage is bigger than L2-04, the inverter will release the excess energy through the brake resistance in case of overvoltage.

L2-05	Under voltage threshold	Range: 200.0V to 500.0V	Default: 350.0V<1>
-------	-------------------------	-------------------------	--------------------

<1> means the value of 380Vclass inverter, and when in 200V class this value is 200.0V.

This value is the judge point of undervoltage fault, when the bus voltage is lower than this value in running status, the inverter will output Err12 undervoltage fault. Meanwhile it can choose undervoltage fault reset mode by F9-17.

L2-06	Random PWM depth	Range: 0 to 6	Default: 0
-------	------------------	---------------	------------

This function is effective only on VF. The attached PWM can soften the monotonous and

harsh motor noise, and decrease the magnetic interrupt to the outside. The effect is different of the attached PWM as the depth is different, 0 means ineffective.

L2-07	0Hz running way	Range: 0 to 2	Default: 0
-------	-----------------	---------------	------------

- 0: No output current
- 1: Normal running
- 2: Output DC braking current F1-16.

L2-08	Limitation of low frequency carrier	Range: 0 to 2	Default: 0
-------	-------------------------------------	---------------	------------

- 0: Default limit mode
- 1: Low frequency carrier frequency is not higher than the 1/2 of relevant control mode.
- 2: No limit and the carrier frequency in all frequency bands are the same.

5.24 Group L3 AIAO Correction Parameter

L3-00	AI1 displayed voltage 1	Range: -9.999V to 10.000V	Default: 3.000V
L3-01	AI1 measured voltage 1	Range: -9.999V to 10.000V	Default: 3.000V
L3-02	AI1 displayed voltage 2	Range: -9.999V to 10.000V	Default: 8.000V
L3-03	AI1 measured voltage 2	Range: -9.999V to 10.000V	Default: 8.000V
L3-04	AI2 displayed voltage 1	Range: -9.999V to 10.000V	Default: 3.000V
L3-05	AI2 measured voltage 1	Range: -9.999V to 10.000V	Default: 3.000V
L3-06	AI2 displayed voltage 2	Range: -9.999V to 10.000V	Default: 8.000V
L3-07	AI2 measured voltage 2	Range: -9.999V to 10.000V	Default: 8.000V

Function codes L3-00 ~ L3-07 are used to revise the deviation between actual analog input value and inverter display AI, in order to eliminate the influence of AI input port zero-deflection and linearity. This group of function codes have been revised before the delivery in the factory, meanwhile users can revise it again according to the actual need, but these parameters will recover to default along with the recover default action. Generally there is no need to revise them.

The detected voltage means the actual voltage through the measure equipment like multimeter. Display voltage means the inverter display value when sampling. AI1, AI2 display voltage respectively corresponds to U1-19, U1-20.

When revising, input two voltage value in each AI input port, and respectively input the detected value from the multimeter and the read value from group U0 to the above function codes, thus the inverter will automatically revise AI zero-deflection and linearity.

L3-12	AO1 target voltage 1	Range: -9.999V to 10.000V	Default: 3.000V
L3-13	AO1 measured voltage 1	Range: -9.999V to 10.000V	Default: 3.000V
L3-14	AO1 target voltage 2	Range: -9.999V to 10.000V	Default: 8.000V
L3-15	AO1 target voltage 2	Range: -9.999V to 10.000V	Default: 8.000V
L3-16	AO2 measured voltage 1	Range: -9.999V to 10.000V	Default: 3.000V
L3-17	AO2 target voltage 1	Range: -9.999V to 10.000V	Default: 3.000V
L3-18	AO2 measured voltage 2	Range: -9.999V to 10.000V	Default: 8.000V
L3-19	AO2 target voltage 2	Range: -9.999V to 10.000V	Default: 8.000V

Function codes L3-12~L3-19 are used to revise the deviation between AO analog actual

output and theoretical output value. They have been revised in factory so there is no need to revise again generally. When recover to default, their value will recover to the revised value on factory.

Target voltage means the theoretical output voltage of the inverter, U1-37 and U1-38 respectively correspond to AO1, AO2 target voltage. Measured voltage means the actual voltage that measured by the equipments like multimeter.

Input target voltage and measured voltage respectively on the corresponding function code when revising, the inverter will revise the output value automatically.

5.25 Group L4 Master-slave Control Parameter

Master-slave control means two or multi inverters exchange the data by point-to-point communication, thus realize the speed synchronization and current balance function among the multi inverters, mainly used in multi-transmission occasions. Such as dredging machine, belt conveyer of coal mine etc. Please set the group F8 correctly before using.

When using 485 communication to conduct master-slave control, the inverter can't communicate with the master machine which adopt 485 communication mode, otherwise there will be fault on the system.

Ensure the master and slave direction

When using master-slave control and synchronous speed, firstly please ensure that the running direction of the master machine and the slave machine is the same. If running direction of master machine and slave machine is not the same, you can adjust the direction by F0-13 or change the wiring order between the inverter and the motor to change the actual running direction.

Master and slave parameter setting

When multi inverter driving the same one load, there are two kinds of master-slave control mode.

1) Master machine control mode F0-03 is set as vector, slave machine is also vector and torque control. It's used in most of the occasions.

2) Master machine control mode F0-03 is set as VF, slave machine is also set as VF. On this condition please set a proper drop rate F7-18, otherwise the current between master and slave will be imbalance.

3) When the mechanical transmission rate of master and slave machine is in accordance, the maximum frequency F0-14 of master and slave machine must keep in accordance.

4) When master machine L4-02=0, the acceleration/ deceleration time of slave machine must set as 0; when master machine L4-02=1, the acceleration/ deceleration time of slave machine must keep same as the master machine.

5) There is only one master machine in the same one system, but slave machine can be multiple. Meanwhile wiring according to the communication mode, SSI3300 only uses 485 communication.

L4-00	Master-slave control selection	Range: 0~1	Default: 0
-------	--------------------------------	------------	------------

0: Prohibited

1: Enable

L4-01	Master-slave machine selection	Range: 0~1	Default: 0
-------	--------------------------------	------------	------------

- 0: Master machine
1: Slave machine

L4-02	Master sending frequency selection	Range: 0~1	Default: 0<2>
-------	------------------------------------	------------	---------------

0: Running frequency; on this condition the acceleration/ deceleration time must be set as 0, otherwise when the master and the slave accelerating or decelerating, the speed will not in synchronization.

1: Target frequency; on this condition it's needed to set a proper acceleration/ deceleration time respectively for master and slave machine, otherwise the acceleration/ deceleration time of master and slave machine will not in synchronization.

L4-03	Command source selection of slave followed the master	Range: 0~1	Default: 0<1>
-------	---	------------	---------------

0: Not follow, it means that the slave will not run after the master starts to run, so it's used to detect if the system communication is normal or not.

1: Follow, it means the slave machine follows the command source of master machine to start or stop synchronously.

L4-04	Slave received frequency coefficient	Range: 0.00%~600.00%	Default: 100.00%<1>
L4-05	Slave received torque coefficient	Range:-10.00 to 10.00	Default: 1.00<1>
L4-06	Slave received torque offset	Range: -50.00% to 50.00%	Default: 0<1>

L4-04~L4-06 are effective only to the slave machine, it's used to define the relationship between slave received data and the master machine.

Assuming that the slave send data x; the slave machine use data Y, the coefficient of slave received data is K(L4-04/L4-05), thus $Y = K * x + b$. When it's frequency $b=0$, and when it's torque $b=L4-06$.

L4-07	Frequency offset threshold	Range: 0.20% to 10.00%	Default: 0.50%
L4-08	Master-slave communication offline detection time	Range: 0.0s to 10.0s	Default: 0.1s

They are used to set the detected time during the communication break between master and slave. There is no detection when the value is 0.

Note: <1> Only effective on slave machine; <2> Only effective on master machine.

5.26 Group L5 Mechanical Braking Function Parameter

L5-00	Braking control selection	Range: 0~1	Default: 0
-------	---------------------------	------------	------------

The band-type braking process is illustrated in below diagram:

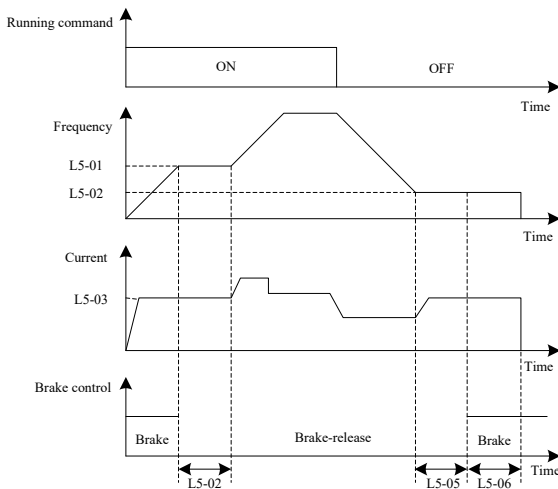

Fig.5-30 Band-type braking control process illustration

The braking process is as below:

- 1) After the inverter received the running command, it accelerates to the brake-release frequency that set by L5-01.
- 2) When the frequency reaches the L5-01 setting part, it outputs brake-release signal by DO terminal NO.32 function “braking control output”, then the control brake is released.
- 3) Running with constant speed at brake-release frequency. In this period, the output current controlled by the inverter is not exceeding the current set by L5-03.
- 4) The inverter is running at brake-release frequency and after the running time reaching the L5-02 set value, it starts to accelerate to the set frequency.
- 5) After the inverter received the stop command, it decelerates to the brake frequency set by L5-04, and running with constant speed at this frequency.
- 6) After the running frequency reached the L5-04 set value, delay the brake frequency holding time set by L5-05, then output brake signal by DO terminal NO.32 function “brake control output”, so the control brake works.
- 7) After the switch value outputs (brake control output) terminal outputs brake signal reaches the value set by L5-06, the inverter blocks the output and enter into the stop status.

L5-01	Braking loosen frequency	Range: 0.00Hz to 20.00Hz	Default: 2.50 Hz
-------	--------------------------	--------------------------	------------------

When the frequency reaches this set value, the switch value output “brake control output” terminal output brake signal, so the control brake is released. This value can be set according to motor rated slip frequency. It’s better to set a larger value on V/F control mode.

L5-02	Braking loosen frequency holding time	Range: 0.0s to 20.0s	Default: 1.0s
-------	---------------------------------------	----------------------	---------------

After the switch value output “brake control output” terminal outputs brake signal, the inverter stops acceleration in this period of time and restart after it reaches this set value. Please set it properly according to the machine release time.

L5-03	Braking period current threshold	Range: 50.0% to 200.0%	Default: 120.0%
-------	----------------------------------	------------------------	-----------------

Before the inverter starts to accelerate from brake-release time (brake machine is not completely released), the current is limited in this value.

L5-04	Braking actuation frequency	Range: 0.00Hz to 20.00Hz	Default: 1.50 Hz
-------	-----------------------------	--------------------------	------------------

After the inverter received the stop command, it decelerates to run until the brake frequency set by L5-04, and running in constant speed with this frequency to wait for outputting brake control signal.

L5-05	Braking actuation delay time	Range: 0.0s to 20.0s	Default: 0.0s
-------	------------------------------	----------------------	---------------

After the running frequency reaches the brake frequency, delay the brake waiting time set by L5-05. Then switch value output “brake control” terminal outputs brake release signal to control the brake.

L5-06	Braking actuation frequency holding time	Range: 0.0s to 20.0s	Default: 1.0s
-------	--	----------------------	---------------

After the switch value output “brake control” terminal output brake release signal, holding for a time set by L5-06, to ensure the brake machine is completely pickup. Then the inverter blocks the output and enter into the stop status.

5.27 Group L6 Wake-up Function Parameter

This group of parameters are mainly used to realize the sleep and wake-up function of constant pressure water supply, so please pay attention to below items:

1) please choose the mode L6-00 to control sleep function based on the application requirements.

2) when using PID in frequency source, if the sleep status PID is calculated is influenced by FA-29, so it must choose PID calculate on stop (FA-29=1).

3) Generally, please set the wake-up frequency ((100%- L6-03 wake-up deviation) * F0-14 maximum output frequency) bigger than the sleep frequency L6-01.

L6-00	Sleep selection	Range: 0~3	Default: 0
-------	-----------------	------------	------------

0: Sleep function is ineffective.

1: Digital input terminal DI control the sleep function.

After defined the NO.53 function of stator digital input DI terminal, it starts to sleep when DI has delayed the valid sleep delay time F6-02.

2: The sleep function is controlled by PID set value and feedback value, at the moment the inverter frequency source must be set as PID. Please refer to 5-28.

3: Control the sleep function according to the running frequency.

During the running process, it will enter into the sleep status when the setting frequency is smaller or equivalent to sleep frequency L6-01. Otherwise, it will enter into the wake-up status when the setting frequency is bigger than the wake-up frequency (L6-03 wake-up deviation* F0-14 maximum output frequency).it will enter into the wake-up status.

L6-01	Sleep frequency	Range: 0.00Hz to 50.00Hz	Default: 0.00Hz<1>
-------	-----------------	--------------------------	--------------------

<1> When L6-00=1, this function is ineffective.

Sleep function come to effect and operation frequency is lower than this value, the inverter will be stopped after sleep delay time L6-02.

Please refer to below illustration: A=PID output; B=PID feedback value.

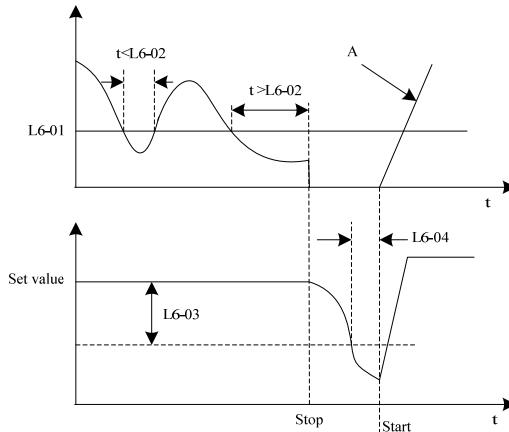

Fig.5-31 Sleep process frequency illustration

L6-02	Sleep delay time	Range: 0.0s to 3600.0s	Default: 20.0s
-------	------------------	------------------------	----------------

It's used to set sleep delay time, and for functions please refer to the diagram 5-27.

L6-03	Wake-up deviation	Range: 0.0% to 100.0%	Default: 10.0%
-------	-------------------	-----------------------	----------------

When L6-00=2, this parameter takes the maximum pressure as reference object, that means the maximum pressure corresponds to 100%.

When L6-00=3, this parameter takes the maximum frequency F0-14 as reference object, that means the maximum frequency corresponds to 100%.

When the wake-up deviation between the given value and feedback value exceeds the value defined by this parameter, after wake-up delay time L6-04, PID adjustor restarts.

When it's in positive effect (FA-4=0), wake-up value= set value - wake-up deviation; when it's in negative effect (FA-4=1), wake-up value= set value+ wake-up deviation.

Please refer to below diagram:

C= wake-up value when parameter FA-04=1;

D= wake-up value when parameter FA-04=0;

E= feedback value is bigger than wake-up value, and holding time is longer than parameter L6-04 (wake-up delay time), then PID function restarts.

E= feedback value is smaller than wake-up value, and holding time is longer than parameter L6-04 (wake-up delay time), then PID function restarts.

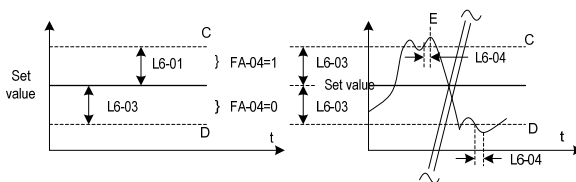

Fig.5-32 Wake-up illustration

L6-04	Wake-up delay time	Range: 0.0s to 3600.0s	Default: 0.5s
-------	--------------------	------------------------	---------------

It's used to set the wake-up delay time, for function please refer to diagram 5-28.

L6-05	Sleep delay time Frequency output selection	Range: 0~1	Default: 0
-------	---	------------	------------

- 0: PID auto-adjustment
- 1: sleep-frequency L6-01

5.28 Group U0 Fault Record Parameter

The inverter has 3 groups of fault record parameters, and all of them are read-only parameters. So it's convenient for users to check and exclude relevant fault information of the inverter. For details please refer to appendix B (function code table) or the seventh chapter (trouble shooting).

5.29 Group U1 State Monitor Parameter

Parameter group U1 is used to monitor the relevant variety information of the inverter on running status. Customers can check it by panel for the convenience of adjustment, and they can also read the parameter group value by communication to monitor the master machine. The communication address is 0x71xx.

U1-00~ U1-31 are the running and stop monitor parameters that defined in F7-29 and F7-30.

U1-00	Running frequency	Minimum unit: 0.01Hz
U1-01	Setting frequency	Minimum unit: 0.01Hz
U1-02	Bus voltage	Minimum unit: 0.1V
U1-03	Output voltage	Minimum unit: 1V
U1-04	Output current	Minimum unit: 0.1A
U1-05	Output power	Minimum unit: 0.1kW
U1-06	DI input status, hexadecimal	Minimum unit: 1

They are used to display the present status value of DI terminal. After switched to binary value, each bit corresponds to one DI input signal. 1 represents that this input is high level signal, while 0 represents this input is low level signal. The corresponding relationship of each bits and input terminals is displayed in below form:

Bit 0	Bit 1	Bit 2	Bit 3	Bit 4	Bit 5	Bit 6	Bit 7
DI1	DI2	DI3	DI4	DI5	Reserve	Reserve	Reserve
Bit 8	Bit9	Bit 10	Bit 11	Bit 12	Bit 13	Bit 14	Bit 15
Reserve	Reserve	Reserve	Reserve	Reserve	Reserve	Reserve	Reserve

U1-07	DO output status, hexadecimal	Minimum unit: 1
-------	-------------------------------	-----------------

It's used to display the output status value of DO terminal. After switched to binary value, each bit corresponds to one DO input signal. 1 represents that this input is high level signal, while 0 represents this input is low level signal. The corresponding relationship of each bits and output terminals is displayed in below form:

Bit 0	Bit 1	Bit 2	Bit 3	Bit 4	Bit 5	Bit 6	Bit 7
Relay 1	Relay 2	Y1	Reserve	Reserve	Reserve	Reserve	Reserve
Bit 8	Bit 9	Bit 10	Bit 11	Bit 12	Bit 13	Bit 14	Bit 15
Reserve	Reserve	Reserve	Reserve	Reserve	Reserve	Reserve	Reserve

U1-08	AI1 voltage after correction	Minimum unit: 0.01V
U1-09	AI2 voltage after correction	Minimum unit: 0.01V
U1-10	PID setting, PID setting (percentage) \times FA-05	Minimum unit: 1
U1-11	PID feedback, PID feedback (percentage) \times FA-05	Minimum unit: 1
U1-12	Count value	Minimum unit: 1
U1-13	Length value	Minimum unit: 1
U1-14	Motor speed	Minimum unit: 1
U1-15	PLC stage	Minimum unit: 1
U1-16	Input pulse frequency	Minimum unit: 0.01kHz
U1-17	Feedback speed	Minimum unit: 0.1Hz
U1-18	Remaining running time of F7-38 setting	Minimum unit: 0.1min
U1-19	AI1 voltage before correction	Minimum unit: 0.001V
U1-20	AI2 voltage before correction	Minimum unit: 0.001v
U1-21	HDI5 high speed pulse sampling linear speed	Minimum unit: 1m/min
U1-22	Load speed display	Minimum unit: 1rpm
U1-23	Current power-on time	Minimum unit: 1min
U1-24	Current running time	Minimum unit: 0.1min
U1-25	Pulse input frequency	Minimum unit: 1Hz
U1-26	Communication setting value	Minimum unit: 0.01%
U1-27	Main frequency X	Minimum unit: 0.01Hz
U1-28	Auxiliary frequency Y	Minimum unit: 0.01Hz
U1-29	Target torque	Minimum unit: 0.1%
U1-30	Output torque	Minimum unit: 0.1%
U1-31	Output torque	Minimum unit: 0.1%
U1-32	Torque upper limit	Minimum unit: 0.1%
U1-33	Target voltage upon V/F separation	Minimum unit: 1V
U1-34	Output voltage upon V/F separation	Minimum unit: 1V
U1-36	Current motor number	Minimum unit: 1
U1-37	AO1 target voltage	Minimum unit: 0.01V
U1-38	AO2 target voltage	Minimum unit: 0.01V

U1-39	AC drive running status: 0: Stop 1: Forward 2: Reverse 3: Fault	Minimum unit: 1
U1-40	AC drive current fault	Minimum unit: 1
U1-41	Agent remaining limited time	Minimum unit: 1h
U1-42	AC input current	Minimum unit: 0.1A
U1-43	PLC current stage remaining time	Minimum unit: 0.1
U1-47	Accumulative running time 1	Minimum unit: 1h
U1-48	Accumulative running time 2	Minimum unit: 1min

Notice:

Accumulative running time = Accumulative running time 1(U1-47) + Accumulative running time 2(U1-48)

Chapter6 EMC(Electromagnetic Compatibility)

6.1 Definition

Electromagnetic compatibility is the ability of the electric equipment to run in the electromagnetic interference environment and implement its function stably without any interference on the electromagnetic interference environment.

6.2 Standard Description

In accordance with the requirements of the national standard GB/T12668.3, the inverter needs to comply with electromagnetic interference and anti-electromagnetic interference requirements.

The existing products at our company are in accordance with the latest international standard -IEC/EN61800-3.

2004(Adjustable speed electrical power drive systems part3:EMC requirements and specific test methods),which is equivalent to GB/T12668.3.

IEC/EN61800-3 assesses the inverter in terms of electromagnetic interference and anti-electronic interference. Electromagnetic interference mainly tests the radiation interference, conduction interference and harmonics interference on the inverter (required for the inverter for civil use)Anti-electromagnetic interference mainly tests the conduction interference rejection, radiation interference rejection, surge interference rejection, fast and mutable pulse group interference rejection, ESD interference rejection and power low frequency end interference rejection (specific test items including: 1. Interference rejection tests of input voltage sag, interrupt and change; 2. Phase conversion interference rejection test; 3. Harmonic input interference rejection test; 4. Input frequency change test; 5. Input voltage unbalance test; 6. input voltage fluctuation test).

In accordance with the above requirements of IEC/EN61800-3 to be tested, our products are installed and used according to Section 6.3 and have a good electromagnetic compatibility in general industry environment.

6.3 EMC Guide

6.3.1 Harmonic Effect

Higher harmonics of power supply may damage the inverter .Thus ,at some places where mains quality is rather poor ,it is recommended to install AC input reactor.

6.3.2 Precautions on Electromagnetic Interference and Installation

There are two kinds of electromagnetic interferences. one is interference of electromagnetic noise in the surrounding environment on the inverter, and the other is interference of inverter on the surrounding equipment.

Installation precautions:

- (1) The earth wire of the inverter and other electric products shall be well grounded.

(2) The power input and output power cables on the inverter and weak current signal cables (e.g. control line) shall not arranged in parallel and vertical arrangement is preferable.

(3) It is recommended that the output power cables of the inverter employ shield cables or steel pipe shielded cables ,all of its shielding layer be grounded reliably, the lead cables of the equipment suffering interferences are recommended to employ twisted-pair shielded control cables and its shielding layer be grounded reliably.

(4) When the length of motor cable is longer than 100 meters, it needs to install output filter or reactor

6.3.3 Handing method for the interference of the surrounding equipment on the inverter

Generally these reason for electromagnetic interference on the inverter is that at some places nearby inverter where plenty of relays, contactors and electromagnetic brakes shall be installed. when the inverter has error action due to the interferences ,the following measures can be taken:

(1) Install surge suppressor on the devise generating interference

(2) Install filter at the input end of the inverter ,refer to Section 7.3.6 the specific operations

(3) The control signal cable of the inverter and cable of detection line shall employ shielded cable and the shielding layers shall be earthed reliably.

6.3.4 Handing method for the interference of inverter on the surrounding equipment

These interference include two types :one is the radiation interference of the inverter, and the other is the conduction interference of the inverter. These two types of interferences cause the surrounding electric equipments which suffer elector magnetic or electrostatic induction. The surrounding equipments hereby produce error action. For the different interferences, their solutions are shown as follows:

(1) For the measuring meters ,receivers and sensors ,this signals are generally weak ,if they which are placed nearby the inverter or together with the inverter in the same control cabinet are easy to suffer interference and to generate error actions .Suggestions to be handled with following methods: put in places far away from the interference source; do not arrange the signal cables with the power cables in parallel and never bind them together; both the signal cables and power cables employ shielded cables and are well earthed; install ferrite magnetic ring(with suppressing frequency of 30h2 to 1000h2)at the output side of the inverter and wind it 2~3 cycles; install EMC output filter in more severe conditions.

(2) When both the equipment suffering interference and the inverter make use of the same power supply, it many cause conduction interference .if the above method cannot remove the interference ,it can install EMC filter between the inverter and the power supply (refer to Section 7.3.6 for the prototyping operation)

(3) The surrounding equipment is separately earthed, which can avoid the interference caused by the leakage current of the inverter's earth wire when common earth mode is adopted.

6.3.5 Leakage current and handling:

There are two forms of leakage current when using the inverter. One is leakage current to the earth, and the other is leakage current between the cables.

(1) Factors influencing the leakage current to the earth and the solutions:

There are distributed capacitance between the lead cables and the earth. The larger the distributed capacitance is, the larger the leakage current will be. The distributed capacitance can be reduced by effectively reducing the distance between the inverter and the motor. The higher the carrier frequency is, the larger the leakage current will be. The leakage current can be reduced by reducing the carrier frequency. However, reducing the carrier frequency may result in addition of motor noise. Note that additional installation of reactor is also an effective method to remove the leakage current.

The leakage current may increase following the addition of circuit current. Therefore, when the motor power is high, the corresponding leakage current will be high too.

(2) Factors of producing leakage current between the cables and solutions:

There is distributed capacitance between the output cables of the inverter. If the current passing the lines has higher harmonic, it may cause resonance and thus result in leakage current. If thermal relay is used, it may generate error action.

The solution is to reduce the carrier frequency or install output reactor. It is recommended that thermal relay not be installed before the motor when using the inverter, and that electronic over current protection function of the inverter be used instead.

6.3.6 Precautions for Installing EMC input filter at the input end of power supply

When add a EMCS filter on the power source input end, please pay attention to below items:

(1) When using the inverter, please follow its rated values strictly. Since the filter belongs to Classification I electric appliances, the metal enclosure of the filter shall be large and the metal ground of the installing cabinet shall be well earthed and have good conduction continuity. Otherwise there may be danger of electric shock and the EMC effect may be greatly affected.

(2) Through the EMC test, it is found that the filter ground must be connected with the PE end of the inverter at the same public earth. Otherwise the EMC effect may be greatly affected.

(3) The filter shall be installed at a place close to the input end of the power supply as much as possible.

(4) The EMC input filter can't be used on the output end of the inverter.

Chapter 7 Trouble Shooting

7.1 Fault Warnings and Solutions

If faults happened on the running process, the inverter will stop to output immediately to protect the motor, and the corresponding fault relay of the inverter has contact action at the same time so the panel will display the fault code. The fault types and regular solutions that corresponding to the fault code are listed below in the table. Details in below form is only for reference, so please don't fix or change it by yourself. If you can't clear out the fault please contact us or the local agent for technical support.

Tab.7-1 Fault warning and solutions

Display	Fault Name	Possible Causes	Solutions
Err01	Inverter unit protection	1: The output circuit is grounded or short circuited. 2: The module overheats. 3: The internal connections become loose. 4: The main control board is faulty, drive board or module is faulty.	1: Eliminate external faults. 2: Check the air filter and the cooling fan. 3: Connect all cables properly. 4: Contact the agent or the manufacturer for help.
Err04	Over current during acceleration	1: The output circuit is grounded or short circuited. 2: Motor parameter is not right. 3: The acceleration time is too short. 4: Manual torque boost or V/F curve is not appropriate. 5: The voltage is too low. 6: The startup operation is performed on the rotating motor. 7: A sudden load is added during acceleration. 8: The AC drive model is of too small.	1: Eliminate external faults. 2: Perform the motor auto-tuning. 3: Increase the acceleration time. 4: Adjust the manual torque boost or V/F curve. 5: Adjust the voltage to normal range. 6: Select rotational speed tracking restart or start the motor after it stops. 7: Remove the added load. 8: Select an AC drive of higher power class.

Display	Fault Name	Possible Causes	Solutions
Err05	Over current during deceleration	<ol style="list-style-type: none"> 1: The output circuit is grounded or short circuited. 2: Motor parameter is not right. 3: The deceleration time is too short. 4: The voltage is too low. 5: A sudden load is added during deceleration. 6: The braking unit and braking resistor are not installed. 7: Magnetic flux brake gain too much 	<ol style="list-style-type: none"> 1: Eliminate external faults. 2: Perform the motor auto-tuning. 3: Increase the deceleration time. 4: Adjust the voltage to normal range. 5: Remove the added load. 6: Install the braking unit and braking resistor. 7: Decrease the over-magnetic flux brake gain.
Err06	Over current at constant speed	<ol style="list-style-type: none"> 1: The output circuit is grounded or short circuited. 2: Motor parameter is not right. 3: The voltage is too low. 4: A sudden load is added during operation. 5: The AC drive model is of too small. 	<ol style="list-style-type: none"> 1: Eliminate external faults. 2: Perform the motor auto-tuning. 3: Adjust the voltage to normal range. 4: Remove the added load. 5: Select an AC drive of higher power class.
Err08	Overvoltage during acceleration	<ol style="list-style-type: none"> 1: The input voltage is too high. 2: An external force drives the motor during acceleration. 3: The acceleration time is too short. 4: The braking unit and braking resistor are not installed. 5: Motor parameter is wrong. 	<ol style="list-style-type: none"> 1: Adjust the voltage to normal range. 2: Cancel the external force or install a braking resistor. 3: Increase the acceleration time. 4: Install the braking unit and braking resistor. 5: Perform the motor auto-tuning.
Err09	Overvoltage during deceleration	<ol style="list-style-type: none"> 1: The input voltage is too high. 2: An external force drives the motor during deceleration. 3: The deceleration time is too short. 4: The braking unit and braking resistor are not installed. 	<ol style="list-style-type: none"> 1: Adjust the voltage to normal range. 2: Cancel the external force or install a braking resistor. 3: Increase the deceleration time. 4: Install the braking unit and braking resistor.
Err10	Overvoltage at constant speed	<ol style="list-style-type: none"> 1: The input voltage is too high. 2: An external force drives the motor during acceleration. 	<ol style="list-style-type: none"> 1: Adjust the voltage to normal range. 2: Cancel the external force

Display	Fault Name	Possible Causes	Solutions
			or install a braking resistor.
Err12	Undervoltage	<ol style="list-style-type: none"> 1. Instantaneous power failure occurs. 2. The input voltage exceeds the allowed range. 3. The DC bus voltage is too low. 4. The rectifier bridge and Buffer resistor are faulty. 5. The drive board is faulty. 6. The control board is faulty. 	<ol style="list-style-type: none"> 1. Reset the fault. 2. Adjust the input voltage to within the allowed range. 3. Seek for maintenance.
Err13	Drive overload	<ol style="list-style-type: none"> 1. The load is too heavy or the rotor is locked. 2. The drive is of too small power class. 	<ol style="list-style-type: none"> 1: Reduce the load, or check the motor, or check the machine whether it is locking the rotor. 2: Select a drive of higher power class.
Err14	Motor overload	<ol style="list-style-type: none"> 1: F9-01istoosmall. 2: The load is too heavy or the rotor is locked. 3: The drive is of too small power class. 	<ol style="list-style-type: none"> 1: SetF9-01correctly. 2: Reduce the load,or check the motor, or check the machine whether it is locking the rotor. 3: Select a drive of higher power class.
Err15	Drive overheat	<ol style="list-style-type: none"> 1: The ambient temperature is too high. 2: The air filter is blocked. 3: The cooling fan is damaged. 4: The thermally sensitive resistor of the module is damaged. 5: The inverter module is damaged. 	<ol style="list-style-type: none"> 1: Lower the ambient temperature. 2: Clean the air filter. 3: Replace the damaged fan. 4: Replace the damaged thermally sensitive resistor. 5: Replace the inverter module.
Err17	Current detection fault	<ol style="list-style-type: none"> 1: The internal connections become loose. 2: The HALL device is faulty. 3: The control or drive board is faulty. 	<ol style="list-style-type: none"> 1: Connect all cables properly. 2: Seek for maintenance.
Err20	Short circuit to ground	The motor is short circuited to the ground.	Replace the cable or motor.

Display	Fault Name	Possible Causes	Solutions
Err23	Power input phase loss	1: The three-phase power input is abnormal. 2: The drive board is faulty. 3: The lightning board is faulty. 4: The main control board is faulty.	1: Eliminate external faults. 2: Seek for maintenance.
Err24	Power output phase loss	1: The cable connecting the AC drive and the motor is faulty. 2: The AC drive's three-phase outputs are unbalanced when the motor is running. 3: The drive board is faulty. 4 The module is faulty.	1: Eliminate external faults. 2: Check whether the motor three-phase winding is normal. 3: Seek for maintenance.
Err25	EEPROM read-write fault	The EEPROM chip is damaged.	Replace the main control board.
Err27	Communication fault	1: The host computer is in abnormal state. 2: The communication cable is faulty. 3: The communication parameters in group F8 are set improperly.	1: Check cabling of the host computer. 2: Check the communication cabling. 3: Set the communication parameters properly.
Err28	External equipment fault	External fault normally closed or normally open signal is input via DI.	Reset the fault.
Err29	Too large speed deviation	1: The load is too heavy and the acceleration time is too short. 2: F9-31 and F9-32 are set incorrectly.	1: Increase the acceleration and deceleration time. 2: Set F9-31 and F9-32 correctly based on the actual situation.
Err30	User-defined fault1	The user-defined fault 1 signal is input via DI.	Reset the fault.
Err31	User-defined fault2	The user-defined fault 2 signal is input via DI.	Reset the fault.
Err32	PID feedback lost during running	The PID feedback is lower than the setting of FA-13.	Check the PID feedback signal or set FA-26 to a proper value.

Display	Fault Name	Possible Causes	Solutions
Err33	Fast current limit fault	1: The load is too heavy or the rotor is locked. 2: The acceleration time is too short.	1: Reduce the load, or change the inverter with larger power. 2: Increase the acceleration time.
Err34	Load becoming 0	The detection is reached. Get more details form F9-28 to F9-30.	Reset the fault or reset F9-28 to F9-30 value
Err35	Control power supply fault	1: The input voltage is not within the allowable range. 2:The power on and off is too frequently.	1: Adjust the input voltage to the allowable range. 2:Extension of power on cycle.
Err37	Data storage fault	Communication between DSP and EEPROM fault.	1: Replace the main control board. 2: Contact the agent or the manufacturer for help.
Err39	Current running time reached	Current running time of AC driver is larger than .F7-38 value.	Reset the fault.
Err40	Accumulative running time reached	The accumulative running time reaches the setting value of F7-20.	Clear the record through the parameter initialization function or set F7-20 to a new value.
Err42	Motor switchover fault during running	Change the selection of the motor via terminal during running of the AC drive.	Perform motor switchover after the AC drive stops.
Err46	Master slave control communication disconnection	1:There is no set host but set the slave machine 2:The communication cable is faulty or communication parameter setting not correct.	1: Set host and reset the fault. 2: Check the communication cabling and communication parameters F8.

7.2 Common Faults and Treating Methods

The inverter will possibly be confront with below faults, please refer to the mentioned methods to have simple diagnosis and find the solutions.

Tab.7-2 Common faults and treating methods

serial number	Fault Name	Possible Causes	Solutions
1	There is no display at power-on.	<ol style="list-style-type: none"> 1: There is no power supply or the power supply is too low. 2: The switching power supply on the drive board is faulty. 3: The rectifier bridge is damaged. 4: The buffer resistor of the drive is damaged. 5: The control board or the keypad is faulty. 6: The cable between the control board and the drive board or keypad breaks. 	<ol style="list-style-type: none"> 1: Check the power supply. 2: Check the bus voltage. 3: Re-connect the keypad and 30-core cables. 4: Contact the agent for technical support.
2	"Err20" is displayed at power-on	<ol style="list-style-type: none"> 1: The motor or the motor output cable is short-circuited to the ground. 2: The AC driver is damage. 	<ol style="list-style-type: none"> 1: Measure the insulation of the motor and the output cable with a megger. 2: Contact the agent for technical support.
3	Err15 (module overheat) fault is reported frequently.	<ol style="list-style-type: none"> 1: The setting of carrier frequency is too high. 2: The cooling fan is damaged, or the air filter is blocked. 3: Components inside the AC drive are damaged (thermal coupler or others). 	<ol style="list-style-type: none"> 1: Reduce the carrier frequency (F0-26). 2: Replace the fan and clean the air filter. 3: Contact the agent for technical support.
4	The motor does not rotate after the AC drive runs.	<ol style="list-style-type: none"> 1: Check the motor and the motor cables. 2: The AC drive parameters are set improperly (motor parameters). 3: The cable between the drive board and the control board is in poor contact. 4: The drive board is faulty. 	<ol style="list-style-type: none"> 1: Ensure the cable between the AC drive and the motor is normal. 2: Replace the motor or clear mechanical faults. 3: Check and re-set motor parameters.

serial number	Fault Name	Possible Causes	Solutions
5	The DI terminals are disabled.	1: The parameters are set incorrectly. 2: The external signal is incorrect. 3: Wrong location of the DI dial switch. 4: The control board is faulty.	1: Check and reset the parameters in group F5. 2: Re-connect the external signal cables. 3. Wrong location of the DI dial switch. 4: Contact the agent for technical support.
6	The AC drive reports over-current and over-voltage frequently	1: The motor parameters are set improperly. 2: The acceleration/deceleration time is improper. 3: The load fluctuates.	1: Re-set motor parameters or re-perform the motor auto-tuning. 2: Set proper acceleration/deceleration time. 3: Contact the agent for technical support.

Appendix A SSI3300 Series Modbus Communication Protocol

SSI3300 series of frequency converters can provide RS232/RS485 communication interface, and use MODBUS communication protocol. The user can realize the central control through computer or PLC. Also it can set the running commands, modify or read the function code parameter, read the working status and fault information of the frequency converter according to the protocol.

1. Communication Protocol Content

This serial communication protocol has defined the content and the working format in serial communication, including master machine polling format (or broadcast) and master machine encoding method. The content includes the function code of the requested action, data transmission, error checking, etc. Same structure is used on the slave machine response, which includes action confirmation, data returning, error checking, etc. If the slave machine has an error in receiving information or cannot complete the requirements from the master machine, it will send a fault signal back as a response to the master machine.

2. Application Mode

The frequency converter connect PC/PLC network with RS232/RS485 bus and single master but multiple slave machines.

3. Bus Structure

(1) Interface mode

RS232/RS485 hardware interface

(2) Transmission mode

It's asynchronous serial and half-duplex transmission mode. For master machine and slave machine, only one can send data and another one receive it at the same time. In the process of serial asynchronous communication, the data is transmitted frame by frame in the form of message.

(3) Topological structure

In single master machine and multiple slave machines system, the setup range of slave address is "1~247", and "0" is the broadcast communication address. The address of the slave machine in net work must be unique.

4. Protocol specification

SSI3300 series frequency converter communication protocol is a asynchronous serial and master-slave Modbus communication protocol, only one facility (master machine) in network can

set up protocol (called “query/command”), other facilities (slave machines) can only response to the “query/command” of master machine according to the data provided, or make relevant action by “query/command” from the master machine. The master machine here means personal computer (PC), industrial controlled facility or programmable logic controller (PLC), etc., the slave machine means SSI3300 frequency converter. The master machine can not only communicate with one slave machine separately, but also broadcast information to all the slave machines. For the separate access to “query/command” of master machine, the slave machine will return information (called response). For the broadcast information from the master machine, the slave machines need not to response to the master machine.

5. Communication frame structure

The Modbus protocol data format of SSI3300 series of frequency convert is as follows:

If use RTU mode, the message must be sent with a pause of at least 3.5 characters time. Different character time is very easy to get under the circumstance of varieties of network baud rates. The first domain of the message transmission is the equipment address, the usable transmissive characters are hexadecimal 0~9, A~F. Network equipment continuously detect the network trunk line, including the pause time. Once the first domain (address domain) is received, all the facilities will decode to make out if it’s sent to their own. After the last characters sent, a pause with at least 3.5 character time buckets indicates the end the message. A new message can be started after the pause.

The entire message frames must be sent as a continuous flow. If there was a pause over 1.5-character time before the frame completed, the receiving equipment will update the incomplete message and assume the next byte as address domain of a new message. Likewise, if a new message was sent following with the previous one during less than 3.5-character time, the receiving equipment will regard it as the extension of the previous message. This will lead to an error, because the result is impossible to be right with the value of CRC domain at last.

RTU frame format:

Frame Header START	3.5 characters time
Slave Address ADR	Contact address:1~247(Set by F8-02)
The command code CMD	03: Read the parameter of the slave machine 06: Write the parameters of the slave machine
The content of the data DATA (N-1)	The content of the DATA: The address of function code parameters; The quantity of function code parameters; The value of function code parameters;
The content of the data DATA (N-2)	
.....	
The content of the data DATA0	
CRC CHK Low order	detection value: CRC16 verified value. low byte is sent previous than High byte.
CRC CHK High order	
END	3.5-characters time

Command instruction (CMD) and data description (DATA)

Command code: 03H, read N words (Word), it can read at most 12 words and N = 1 ~ 12 words. Specific format is as below:

Frame of reading command from the master:

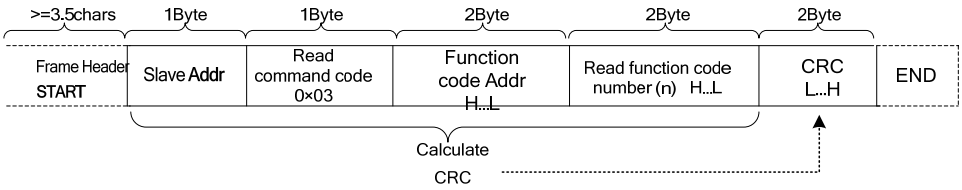

Frame of reading response command from the slave:

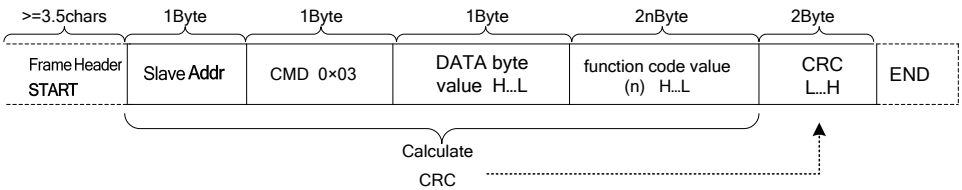

Frame of writing command from the master:

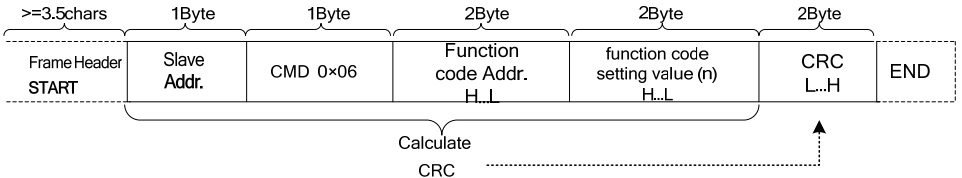

Frame of writing response command from the slave:

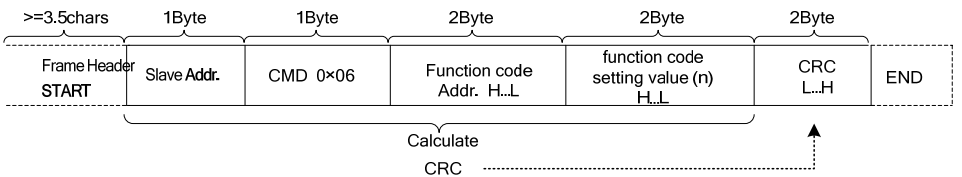

Note: If the slave detects a communication frame error or reading/writing failure is caused by other reasons, an error frame will be returned as follows:

Frame of reading response error from the slave:

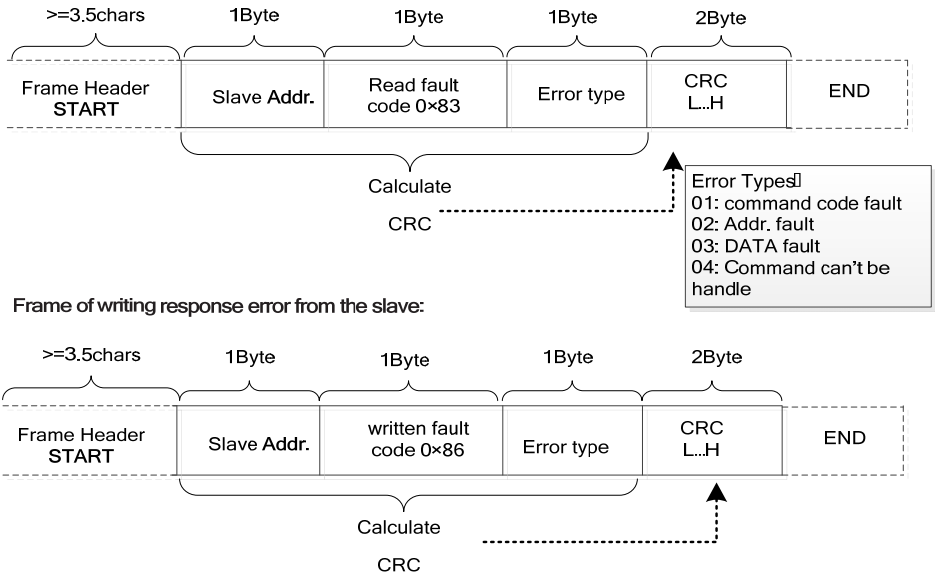

Example: reading continuous 2 parameters from frequency convert F0~03 whose slave machine address F8-02= 01.

Command from the master machine:

Frame Header >=3.5chars	Slave Addr. 0x01	Read function code 0x03	Function code Addr. 0xF0 0x03	Read function code value 0x00 0x02	CRC 0x07 0x0B	END
----------------------------	---------------------	----------------------------	-------------------------------------	--	---------------------	-----

Reply from the slave machine:

Frame Header >=3.5chars	Slave Addr. 0x01	Read function code 0x03	DATA byte value 0x04	F0_03 parameter value 0x00 0x00	F0_04 parameter value 0x00 0x00	CRC 0xFA 0x33	END
----------------------------	---------------------	----------------------------	-------------------------	------------------------------------	---------------------------------------	---------------------	-----

6. Verification mode (CRC verification mode)

CRC (Cyclical Redundancy Check) use RTU frame format, the message includes error checking domain based on CRC method. CRC domain checked the content of the entire message. CRC domain is 2 bytes, containing a 16-bit binary value. It's added to the message after calculated by transmission equipment. The receiving device recalculates the CRC message after the information received, and compare with the value in the received CRC. If the two CRC values are not equal, it indicates that errors happened on transmission.

CRC saves 0xFFFF firstly, and then call a process to deal continuous 8-bit bytes in the message with the value in current register. Only 8 bit data in each character is effective to CRC, start bit, stop bit and the parity bit are ineffective.

During the process of CRC, each 8-bit character individually exclusive or the content in the register (XOR), the result shifts to the least significant bit while the most significant bit is filled with a "0". The LSB is picked out to test, if the LSB is 1, the register exclusive or the preset value, if the LSB is 0, no action taken. The whole process will be repeated 8 times. When the last bit (the 8th bit) is done, the next 8-bit character separately exclusive or the current value in the register again. The final value in the register is the CRC value after all the bytes in the message have been dealt with.

When adding CRC to message, the lower bytes are add previous than the higher bytes. The simple CRC function is as follow:

```

unsigned int crc_chk_value (unsigned char *data_value, unsigned char length)
{
    unsigned int crc_value=0xFFFF;
    int i;
    while (length-->0)
    {
        crc_value^=*data_value++;
        for (i=0;i<8;i++)
        {
            if (crc_value&0x0001)
                crc_value= (crc_value>>1) ^0xa001;
            else
            {
                crc_value=crc_value>>1;
            }
        }
    }
    return (crc_value) ;
}

```

7. The definition of communication parameter address

This part is the content about communication, which used for controlling the running and working status of the frequency convert, and set relevant parameter.

Parameter of read and write function code (some function code can't be changed, only for supplier and monitor usage):

Labeling rule of function code address:

Use the group number and mark number of the function code as parameter address rule:

The high bytes: F0~FF (group F)、H0~HF (group H)、L0~LF (group L)、n0~nF (group N)、70~7F (group U) the low byte: 00~FF

For example: F0-11, the address indicated as F00B;

Attention:

Group FF: The parameter can neither be read nor be altered.

Group U: The parameter can only be read, but not be altered.

Some parameter can't be changed when the frequency convert is on running status; some parameter can't be changed regardless of any status of the frequency convert; please pay attention to the range, unit and relevant instruction when changing the function code parameter.

Group number of function code	Access address of communication	Function code address of communication revise the RAM
Group F0~FE	0xF000~0xFEFE	0x0000~0x0EFF
Group H0~HF	0xA000~0xAFFF	0x4000~0x4FFF
Group L0~LF	0xB000~0xBFFF	0x5000~0x5FFF
Group n0~nF	0xC000~0xCFFF	0x6000~0x6FFF
Group U0、U1	0x70xx、0x71xx	

Pay attention that if the EEPROM is stored continuously, the service life will be reduced. So there is no need to store some function code on the communication mode, just need to change the value in RAM.

If it's group F of the parameter to realize this function, just need to change high byte from F to 0 on the function code address.

If it's group A of the parameter to realize this function, just need to change high byte from A to 4 on the function code address.

The relevant function code address indicated as below:

High byte: 00~0F (group F)、40~4F (group A) the low byte: 00~FF

For example: function code F0-11 doesn't store in EEPROM, the address indicated as 000B; this address means that it only can write RAM, but can't use the read action, if it's being read, the address is ineffective.

Stop / Run Parameter

Parameter Address (HEX)	Parameter Description
0x1000/9000	1000:*Communication set value(-1000~1000) (decimal) (readable and writable) (minimum unit:0.01%),Read/Write
	9000: range(0HZ~F0-14) (minimum unit:0.01Hz), Read/Write
0x1001	Set frequency (minimum unit:0.01Hz), Read-only
0x1002	Running frequency (minimum unit:0.01Hz), Read-only
0x1003	Busbar voltage (minimum unit: 0.01V), Read-only
0x1004	Output voltage (minimum unit: 0.1V), Read-only
0x1005	Output current (minimum unit: 0.1A), Read-only
0x1006	Output power (minimum unit: 0.1kw), Read-only
0x1007	DI input flag (minimum unit: 1), Read-only
0x1008	DO output flag (minimum unit: 1), Read-only
0x1009	PID set (minimum unit: 1), Read-only
0x100A	PID feedback (minimum unit:1), Read-only
0x100B	AI1 voltage (minimum unit: 0.01V), Read-only
0x100C	AI2 voltage (minimum unit: 0.01V), Read-only
0x100D	AO1 output voltage (minimum unit: 0.01V), Read-only
0x100E	PLC step (minimum unit: 1), Read-only
0x100F	Rotate speed (minimum unit: 1rpm), Read-only
0x1010	Count value input (minimum unit: 1), Read-only
0x1011	Pulse frequency input (minimum unit: 0.01kHz), Read-only
0x1012	Feedback speed (minimum unit: 0.1Hz), Read-only
0x1013	The remaining run time (minimum unit: 0.1 min), Read-only
0x1014	Voltage before AI1 revised (minimum unit: 0.001V), Read-only
0x1015	Voltage before AI2 revised (minimum unit: 0.001V), Read-only
0x1016	The actual linear speed (minimum unit: 1m/min), Read-only
0x1017	Load speed (minimum unit: user-defined, refer to F7-31), Read-only
0x1018	present power-on time (minimum unit: 1min), Read-only
0x1019	Present run time (minimum unit: 0.1min), Read-only
0x101A	Pulse frequency input (minimum unit: 1Hz), Read-only

0x101B	Main frequency X display (minimum unit: 0.01Hz) , Read-only
0x101C	Auxiliary frequency Y display (minimum unit: 0.01Hz) , Read-only
0x101D	Target torque (minimum unit: 0.1%), regard motor rated torque as 100%, Read-only
0x101E	Output torque (minimum unit: 0.1%), regard motor rated torque as 100%, Read-only
0x101F	Output torque (minimum unit: 0.1%), regard inverter rated current as 100%, Read-only
0x1020	Upper limit torque (minimum unit: 0.1%), regard inverter rated current as 100%, Read-only
0x1021	VF separate target voltage (minimum unit: 1V) , Read-only
0x1022	VF separate output voltage (minimum unit: 1V) , Read-only
0x1023	Reserved, Read-only
0x1024	Motor 1/2 direction (minimum unit: 1) , Read-only
0x1025	Length value input (minimum unit: 1) , Read-only
0x1026	AO2 output voltage (minimum unit: 0.1V) , Read-only
0x1027	Status of the invert (minimum unit: 1) , Read-only
0x1028	Present malfunction (minimum unit: 1) , Read-only

Example 1: read the run frequency of the first machine: 0x01 0x03 0x10 0x02 0x00 0x01 0x21 0x0A 0x10 0x02 (1002) run frequency address, 0x00 0x01 (0001) one data 0x21 0x0A (210A) CRC verified value.

Example 2: read the busbar voltage, output voltage, output current of the first machine at the same time: 0x01 0x03 0x10 0x03 0x00 0x03 CRC verified value, the meaning of the data is similar to example 1.

Attention: Communication set value is a relative percentage value, 10000 correspond to 100.00% and -10000 correspond to -100.00%
 For the data of frequency dimension, this percentage is the percentage of the relative maximum frequency (F0-14); for the data of torque, this percentage is F3-21, F3-23, H3-21, H3-23.

Control command input to the frequency convert: (Write only)

Command word address (HEX)	Command word function
0x2000	0001: Forward operation
	0002: Reverse operation
	0003: Forward jog
	0004: Reverse jog
	0005: Free stop
	0006: Slow-down stop

	0007: Fault reset
--	-------------------

Example 3: give command forward rotating to the second machine: 0x02 0x06 0x20 0x00 0x00 0x01 CRC verified value

Read the status of the frequency convert: (read only)

Status word address (HEX)	Status word function
0x3000	0001: Forward operation
	0002: Reverse operation
	0003: Stop

Digital output terminal control: (write only)

Command address (HEX)	Command content
0x2001	BIT0: RELAY1 output control BIT1: RELAY2 output control BIT2: DO1 output control

Attention: D0 output terminal need to choose 16 (communication control) function.

Analog AO1 control: (write only)

Command address (HEX)	Command content
0x2002	0~7FFF represent 0%~100%

Analog AO2 control: (write only)

Command address (HEX)	Command content
0x2003	0~7FFF represent 0%~100%

Attention: AO output need to choose 7 (communication control output) function.

Fault descriptions of the frequency convert:

The fault address (HEX)	The fault detail information
0x8000	0000: Fault free
	0001: Reserve
	0002: Reserve
	0003: Reserve
	0004: Accelerated over current
	0005: Decelerated over current
	0006: Constant over current
	0007: Over current on stop
	0008: Accelerated over voltage
	0009: Decelerated over voltage
	000A: Constant over voltage
	000B: Over voltage on stop
	000C: Undervoltage fault

0x8000	000D: Frequency convert overload 000E: Motor overloading 000F: Module over heat 0010: Reserve 0011: Current detection fault 0012: Reserve 0013: Reserve 0014: Earth short circuit of the motor 0015: Tuning fault of the motor 0016: Reserve 0017: Shortage- phase on input 0018: Shortage- phase on output 0019: Abnormal read and write on EEPROM 001A: Enter the password more than the limit times 001B: Abnormal communication 001C: External fault 001D: Over speed deviation 001E: Fault 1 that user defined 001F: Fault 2 that user defined 0020: Lost the PID feedback on running 0021: Limit current fault of the hardware 0022: Off load 0023: Overload on the buffer resistance 0024: Abnormal contactor 0025: The agent running time is up 0026: Over temperature of the motor 0027: Present running time is up 0028: Accumulated running time is up 0029: Power-on time is up 002A: Fault on switching the motor 002B: Over speed of the motor 002C: Reserve 002D: Reserve 002E: Reserve 002F: Fault on point- to- point communication of slave machine
--------	---

When it has fault on communication, the return address is: reading fault 83XX, writing fault 86XX.

Appendix B Function Code Table

The symbols in the function code table are described as follows:

"☆":The parameter can be modified when the AC drive is in either stop or running state.

"★":The parameter cannot be modified when the AC drive is in the running state.

"○":The parameter is the actually measured value and cannot be modified.

"●":The parameter is factory parameter and can be set only by the manufacturer

Enhancement code: group H0~group H3, group L0~group L3, are started by function code parameter F7-75.

Function Code	Parameter Name	Setting Range	Default	Property
Group F0: Standard Function Parameters				
F0-00	Product model	Product model: 5 digital display, 2 decimal point	53#.#	●
F0-01	G/P type display 0: G type1: P type	0: Heavy duty 1: Normal duty	0	●
F0-02	Rated driver current	0.1A to 3000.0A	Model dependent	●
F0-03	Control mode	1: Sensor-less flux vector control (SFVC). 2: Voltage/Frequency (V/F) control.	2	★
F0-04	Running command source selection	0: Operation keypad control (LED off). 1: Terminal control (LED on). 2: Communication control (LED blinking).	0	★
F0-05	Base frequency for modification during running	0: Running frequency. 1: Set frequency.	0	★
F0-06	Main frequency source X selection	0: UP/ DOWN setting (non-recorded after stop). 1: UP/ DOWN setting (retentive after stop). 2: AI1 3: AI2 4: Multi-speed. 5: Simple PLC. 6: PID 7: Communication setting. 8: Pulse setting.	1	★
F0-07	Auxiliary frequency source Y selection	0: UP/ DOWN setting (non-recorded after stop). 1: UP/ DOWN setting	0	★

Function Code	Parameter Name	Setting Range	Default	Property
		(Retentive after stop). 2: AI1 3: AI2 4: Multi-reference. 5: Simple PLC. 6: PID 7: Communication setting. 8: Pulse setting.		
F0-08	Range of auxiliary frequency Y selection	0: Relative to maximum frequency. 1: Relative to main frequency X.	0	☆
F0-09	Range of auxiliary frequency Y	0%~100%	100%	☆
F0-10	Frequency source selection	Unit's digit (Frequency source selection). 0: Main frequency source X. 1: X and Y operation result. 2: Switchover between X and Y (by DI terminal). 3: Switchover between X and "X and Y superposition" (by DI terminal). 4: Switchover between Y and "X and Y superposition" (by DI terminal). Ten's digit() 0: X+Y 1: X-Y 2: Max(X,Y) 3: Min(X,Y)	00	☆
F0-11	Preset frequency	0.00 to maximum frequency F0-14.	50.00Hz	☆
F0-13	Rotation direction	0: Same direction	0	☆

Function Code	Parameter Name	Setting Range	Default	Property
		1: Reverse direction 2: Reverse forbidden		
F0-14	Maximum output frequency	50.0Hz~1200.0 Hz(F0-20=1) 50.0Hz~600.00 Hz(F0-20=2)	50.00Hz	★
F0-15	Frequency source upper limit	0: Set by F0-16 1: AI1 2: AI2 3: Communication setting 4: Pulse setting	0	★
F0-16	Frequency upper limit	Frequency lower limit(F0-18)to maximum frequency (F0-14)	50.0Hz	☆
F0-17	Frequency upper limit offset	0.00 Hz to maximum frequency (F0-14).	0.00Hz	☆
F0-18	Frequency lower limit	0.00 Hz to frequency upper limits (F0-16).	0.00Hz	☆
F0-19	Command source binding select	Unit's digit: Binding operation keypad command to frequency source. 0: No Binding 1: Digital setting 2: AI1 3: AI2 4: Multi-speed 5: Simple PLC 6: PID 7: Communication setting. 8: Pulse setting (HDI5).	000	☆

Function Code	Parameter Name	Setting Range	Default	Property
F0-19	Command source binding select	Ten's digit: Binding operation terminal command to frequency source. Hundred's digit: Binding operation communication command to frequency source. Thousand's digit: Reserved.	000	☆
F0-20	Frequency fractional selection	1: 0.1Hz 2: 0.01Hz	2	★
F0-21	Acceleration/Deceleration time unit	0: 1s 1: 0.1s 2: 0.01s	1	★
F0-22	Acceleration/Deceleration time base frequency	0: Maximum frequency (F0-14) 1: Set frequency 2: Rated motor frequency	0	★
F0-23	Acceleration time 1	0s~3000s (F0-21 = 0) 0.0s~3000.0s (F0-21 = 1) 0.00s~300.00s (F0-21 = 2)	10.0s	☆
F0-24	Deceleration time 1	0s~3000s (F0-21 = 0) 0.0s~3000.0s (F0-21 = 1) 0.00s~300.00s (F0-21 = 2)	10.0s	☆
F0-25	Over modulation voltage boost	0% to 10%	3%	★
F0-26	Carrier frequency	0.5kHz~16.0kHz	Model dependent	☆
F0-27	Carrier frequency adjustment with temperature	0: No 1: Yes	1	☆
F0-28	Initialization parameters	0:No operation. 1:Restore factory parameters, except motor parameters, record information and F0-20.	0	★

Function Code	Parameter Name	Setting Range	Default	Property
		2:Clear the record information. 3:Backup the current user parameters. 4:User parameter backup recovery.		
F0-29	LCD upload or download parameter selection	0:no function 1:Download parameter to LCD 2:only upload F4 function parameters 3: Upload parameters except the F4 group 4: Upload all the parameters	0	☆
Group F1: Start/ Stop Control				
F1-00	Start mode	0: Direct start. 1: Rotational speed tracking restart. 2: Pre-excited start(asynchronous motor).	0	☆
F1-01	Rotational speed tracking mode	0: From frequency at stop 1: From zero speed 2: From maximum frequency	0	★
F1-02	Max current of rotational speed tracking	30%~150%	100%	★
F1-03	Rotational speed tracking speed	1~100	20	☆
F1-04	Startup frequency	0.00Hz~10.00Hz	0.00Hz	☆
F1-05	Startup frequency holding time	0.0s~100.0s	0.0s	★
F1-06	Startup DC braking current/ Pre-excited current	0%~100%	0%	★
F1-07	Startup DC braking time/ Pre-excited time	0.0s~100.0s	0.0s	★

Function Code	Parameter Name	Setting Range	Default	Property
F1-08	Acceleration/Deceleration mode	0: Linear 1: S-curve	0	★
F1-09	Acceleration time proportion of S-curve start segment	0.00%~80.00%	20.00%	★
F1-10	Deceleration time proportion of S-curve start segment	0.00%~80.00%	20.00%	★
F1-11	Acceleration time proportion of S-curve end segment	0.00%~80.00%	20.00%	★
F1-12	Deceleration time proportion of S-curve end segment	0.00%~80.00%	20.00%	★
F1-13	Stop mode	0: Decelerate to stop 1: Coast to stop	0	☆
F1-14	Initial frequency of stop DC braking	0.00HZ ~ maximum frequency (F0-14)	0.00Hz	☆
F1-15	Waiting time of stop DC braking	0.0s~100.0s	0.0s	☆
F1-16	Stop DC braking current	0%~100%	0%	☆
F1-17	Stop DC braking time	0.0s~36.0s	0.0s	☆
F1-21	Demagnetization time	0.01s~3.00s	0.50s	★
F1-23	Nonstop at instantaneous stop (when power fail) mode selection	0: Ineffective 1: Automatic start at power fluctuation 2: Decelerate to stop.	0	★
F1-24	Deceleration time of nonstop at instantaneous stop	0.0s to 100.0s	10.0s	★
F1-25	Effective voltage of nonstop at instantaneous stop	60% to 85%	80%	★

Function Code	Parameter Name	Setting Range	Default	Property
F1-26	Recovery voltage of nonstop at instantaneous stop	85% to 100%	90%	★
F1-27	Detection time of instantaneous stop nonstop recovery voltage	0.0s to 300.0s	0.3s	★
F1-28	Auto-regulation gain of nonstop at instantaneous stop	0 to 100	40	☆
F1-29	Auto-regulation integral time of nonstop at instantaneous stop	1 to 100	20	☆
Group F2:V/F Control Parameters				
F2-00	V/F curve setting	0: Linear V/F. 1: Multi-point V/F. 2: Square V/F. 3: 1.7-power V/F. 4: 1.5-power V/F. 5: 1.3-power V/F. 6: Voltage and frequency complete separation. 7: Voltage and frequency half separation.	0	★
F2-01	Torque boost	0.0%~30.0%	0.0%	☆
F2-02	Cut-off frequency of torque boost	0.00 Hz to maximum output frequency (F0-14).	25.00Hz	★
F2-03	Multi-point V/F frequency 1 (F1)	0.00Hz to F2-05	3.00Hz	★
F2-04	Multi-point V/F voltage 1 (V1)	0.0% to 100.0%	8.0%	★
F2-05	Multi-point V/F frequency 2 (F2)	F0-05 to F2-07	10.00Hz	★

Function Code	Parameter Name	Setting Range	Default	Property
F2-06	Multi-point V/F voltage 2 (V2)	0.0% to 100.0%	20.0%	★
F2-07	Multi-point V/F frequency 3 (F3)	0.00Hz to 50.00Hz	50.00Hz	★
F2-08	Multi-point V/F voltage 3 (V3)	0.0% to 100.0%	100.0%	★
F2-09	Slip compensation ratio	0.0% to 200.0%	50.0%	☆
F2-10	V/F Magnetic flux brake Gain	0 to 200	100	☆
F2-11	Oscillation suppression gain	0 to 100	Model dependent	☆
F2-13	Slip compensation time	0.02s to 1.00s	0.30s	☆
F2-15	Output voltage source for voltage and frequency separation	0: Digital setting (F2-16). 1: AI1 2: AI2 3: Multi-reference 4: Simple PLC 5: PID 6: Communication setting. 7: Pulse setting (DI5). 100.0% corresponds to the rated.	0	☆
F2-16	Voltage digital setting for V/F separation	0 V to rated motor voltage	0V	☆
F2-17	Voltage rise time of V/F separation	0.0s to 3000.0s	1.0s	☆
F2-18	Voltage decline time of V/F separation	0.0s to 3000.0s	1.0s	☆
F2-19	Stop mode selection upon V/F separation	0: Frequency and voltage declining independently. 1: Frequency declining after voltage declines to 0.	0	☆
Group F3: Vector Control Parameters				

Function Code	Parameter Name	Setting Range	Default	Property
F3-00	Switchover frequency 1	1.00Hz to F3-02	5.00Hz	☆
F3-02	Switchover frequency 2	F3-00 to F0-14	10.00Hz	☆
F3-04	Speed loop proportional gain at low frequency	1.0 to 10.0	4.0	☆
F3-05	Speed loop integral time at low frequency	0.01s to 10.00s	0.50s	☆
F3-06	Speed loop proportional gain at high frequency	1.0 to 10.0	2.0	☆
F3-07	Speed loop integral time at high frequency	0.01s to 10.00s	1.00s	☆
F3-08	Speed loop integral property	0: Integral take effect 1: Integral separation	0	★
F3-11	Torque adjustment proportional gain Kp	0 to 30000	2200	☆
F3-12	Torque adjustment integral gain Ki	0 to 30000	1500	☆
F3-13	Excitation adjustment proportional gain Kp	0 to 30000	2200	☆
F3-14	Excitation adjustment integral gain Ki	0 to 30000	1500	☆
F3-15	Flux braking gain	0 to 200	0	☆
F3-16	Field weakening torque correction ratio	50% to 200%	100%	☆
F3-17	Slip compensation gain	50% to 200%	100%	☆
F3-18	Speed loop feedback filter time	0.000s to 1.000s	0.015s	☆
F3-19	Speed loop output filter time	0.000s to 1.000s	0.000s	☆
F3-20	Source of power-driven torque upper limit	0: F3-21 1: AI1	0	☆

Function Code	Parameter Name	Setting Range	Default	Property
		2: AI2 3: Communication setting 4: Pulse setting (DI5) (Analog range corresponds to F3-21)		
F3-21	Power-driven torque upper limit	0.0% to 200.0%	150.0%	☆
F3-22	Upper limit source of braking torque	0: F3-23 1: AI1 2: AI2 3: Communication setting 4: Pulse setting (DI5) (Analog range corresponds to F3-23)	0	☆
F3-23	Braking torque upper limit	0.0% to 200.0%	150.0%	☆
Group F4: Motor 1 Parameters				
F4-00	Auto-tuning selection	0: No auto-tuning 1: Static auto-tuning 2: Complete auto-tuning	0	★
F4-01	Rated motor 1 power	0.1kW to 1000.0kW	Model dependent	★
F4-02	Rated motor 1 voltage	0V to 1500V	380	★
F4-03	Number of pole pairs of motor 1	2 to 64	Model dependent	○
F4-04	Rated motor 1 current	0.01A to 600.00 A (motor rated power ≤30 kW). 0.1A to 6000.0 A (motor rated power >30kW).	F4-01 dependent	★
F4-05	Rated motor frequency	0.01Hz to F0-14	50.00Hz	★
F4-06	Rated motor 1 rotational	0rpm to 60000rpm	F4-01	★

Function Code	Parameter Name	Setting Range	Default	Property
	speed		dependent	
F4-07	Motor 1 no-load current	0.01A to F4-04 A (motor rated power ≤30 kW). 0.1A to F4-04 A (motor rated power >30kW).	Model dependent	★
F4-08	Motor 1 stator resistance	0.001Ωto 65.535Ω	Model dependent	★
F4-09	Motor 1 rotor resistance	0.001Ωto 65.535Ω	Model dependent	★
F4-10	Motor 1 mutual inductive	0.1mH to 6553.5mH	Model dependent	★
F4-11	Motor 1 leakage inductive	0.01mH to 655.35mH	Model dependent	★
F4-12	Acceleration time of complete auto-tuning	1.0s to 6000.0s	10.0s	☆
F4-13	Deceleration time of complete auto-tuning	1.0s to 6000.0s	10.0s	☆
Group F5: Input Terminals				
F5-00	DI1 function selection	0: No function 1: Forward RUN (FWD)	1	★
F5-01	DI2 function selection	2: Reverse RUN (REV)	2	★
F5-02	DI3function selection	3: Three-wire control 4: Forward JOG (FJOG)	9	★
F5-03	DI4 function selection	5: Reverse JOG (RJOG)	12	★

Function Code	Parameter Name	Setting Range	Default	Property
F5-04	DI5 function selection	6: Speed increase 7: Speed Decrease 8: Coast to stop 9: Fault reset (RESET) 10: RUN pause 11: External fault normally open (NO) input. 12: Constant speed 1 13: Constant speed 2 14: Constant speed 3 15: Constant speed 4 16: Terminal 1 for acceleration/ deceleration time selection	13	★
F5-05	DI6 function selection	17: DI for acceleration/ deceleration time selection 18: Frequency source switchover 19 : MOTPOT setting clear (terminal, keypad) 20: Command source switchover terminal 1 21 : Acceleration/Deceleration prohibited 22: PID pause 23: PLC status reset 24: Swing pause 25: Timer trigger input 26 : Immediate DC injection	13	★

Function Code	Parameter Name	Setting Range	Default	Property
F5-06	DI7 function selection	braking 27: External fault normally closed (NC) input 28: Counter input 29: Counter reset 30: Length count input 31: Length reset 32: Torque control prohibited. 33: Pulse input (enabled only for DI5). 34 : Frequency modification forbidden. 35: PID action direction reverses. 36: ExternalSTOPterminal1. 37: Command source switchover terminal 2 38: PID integral disabled 39: Switchover between main frequency source X and preset frequency 40: Switchover between auxiliary frequency source Y and preset frequency 41: Switchover between motor 1 and motor 2 42: Reserved 43: PID parameter switchover 44: Speed control/Torque control switchover 45: Emergency stop	13	★

Function Code	Parameter Name	Setting Range	Default	Property
F5-06	DI7 function selection	46: External STOP terminal 2 47: Deceleration DC injection braking 48: Clear the current running time 49: Switchover between two-line mode and three-line mode 50: Reverse run prohibited 51: User- defined fault 1 52: User-defined fault 2 53: Dormant input	13	★
F5-10	DI filter time	0.000 to 1.000s	0.010s	☆
F5-11	Terminal command mode	0: Two-line mode 1 1: Two-line mode 2 2: Three-line mode 1 3: Three-line mode 2	0	★
F5-12	Terminal UP/DOWN rate	0.01Hz/s to 100.00Hz/s	1.00Hz/s	☆
F5-13	Terminal effective mode 1	0: High level 1: Low level Unit's:DI1; Ten's:DI2; Hundred's:DI3; Kilobit:DI4; Myriabit:DI5	00000	★
F5-15	All minimum input	0.00V to 10.00V	0.00V	☆
F5-16	Corresponding setting of All minimum input	-100.0% to 100.00%	0.0%	☆
F5-17	All maximum input	0.00V to 10.00V	10.00V	☆
F5-18	Corresponding setting of All maximum	-100.0% to 100.00%	100.0%	☆

Function Code	Parameter Name	Setting Range	Default	Property
F5-19	AI1 filter time	0.00s to 10.00s	0.10s	☆
F5-20	AI2 minimum input	0.00V to 10.00V	0.00V	☆
F5-21	Corresponding setting of AI2 minimum input	-100.0% to 100.00%	0.0%	☆
F5-22	AI2 maximum input	0.00V to 10.00V	10.00V	☆
F5-23	Corresponding setting of AI2 maximum	-100.0% to 100.00%	100.0%	☆
F5-24	AI2 filter time	0.00s to 10.00s	0.10s	☆
F5-30	Pulse minimum input	0.00KHz to 50.00KHz	0.00KHz	☆
F5-31	Corresponding setting of pulse minimum input	-100.0% to 100.00%	0.0%	☆
F5-32	Pulse maximum input	0.00KHz to 50.00KHz	50.00KHz	☆
F5-33	Corresponding setting of pulse maximum input	-100.0% to 100.00%	0.0%	☆
F5-34	Pulse filter time	0.00s to 10.00s	0.10s	☆
F5-35	DI1 On delay time	0.0s to 3600.0s	0.0s	☆
F5-36	DI1 Off delay time	0.0s to 3600.0s	0.0s	☆
F5-37	DI2 On delay time	0.0s to 3600.0s	0.0s	☆
F5-38	DI2 Off delay time	0.0s to 3600.0s	0.0s	☆
F5-39	DI3 On delay time	0.0s to 3600.0s	0.0s	☆
F5-40	DI3 Off delay time	0.0s to 3600.0s	0.0s	☆
F5-41	AI1 function selection as DI terminal	0 to 53 as DI terminal function.	0	★
F5-42	AI2 function selection as DI terminal	0 to 53 as DI terminal function.	0	★

Function Code	Parameter Name	Setting Range	Default	Property
F5-44	AI effective mode selection as DI terminal	Unit's digit(AI1). 0: High level effective. 1: Low level effective. Ten's digit(AI2). 0: High level effective. 1: Low level effective. Hundred's digit::reserved	00	☆
F5-45	AI curve selection	Unit's digit (AI1 curve selection) 0: 2 points curve. 1: Multi-point curve 1. 2: Multi-point curve 2. Ten's digit (AI2 curve selection). 0: 2 points curve 1: Multi-point curve 1 2: Multi-point curve 2 Hundred's digit: reserved	00	☆
F5-46	AI Signal input type selection	Unit's digit:AI1; Ten's digit:AI2 0:Voltage style 1:Current style	00	☆
Group F6: Output Terminals				
F6-00	Relay 1 function	0: No output 1: AC drive running 2: Fault output 3: Frequency-level detection FDT1 reached 4: Frequency reached	2	☆

Function Code	Parameter Name	Setting Range	Default	Property
F6-01	Relay 2 function	5: Zero-speed running (no output at stop) 6: Motor overload pre-warning 7: AC drive overload pre-warning	1	☆
F6-02	Y1 function	8: PLC cycle completed 9: Accumulative running time reached 10: Frequency limited 11: Ready for RUN 12: AI1>AI2 13: Frequency upper limit reached 14: Frequency lower limit reached 15: Undervoltage state output 16: Communication setting 17: Timer output 18: Reverse running 19: Reserved 20: Length reached 21: Torque limited 22: Current 1 reached 23: Frequency 1 reached 24: Module temperature reached 25: Load lost 26: Accumulative power-on time reached 27: Clocking reached output 28: Current running time reached 29: Set count value reached 30: Designated count value reached	1	☆

Function Code	Parameter Name	Setting Range	Default	Property
		31: Motor 1 and motor 2 indication 32: Brake control output 33: Zero-speed running 2 (having output at stop) 34: Frequency level detection FDT2 output 35: Zero current state 36: Software over current 37: Frequency lower limit reached (having output at stop) 38: Alarm output 39: Reserved 40: AI1 input overrun 41: Reserved 42: Reserved 43: Frequency 2 reached 44: Current 2 reached 45: Fault output		
F6-04	FM terminal output selection	0: pulse output (FMP) 1: open loop collector switch value output (FMR)	0	☆
F6-05	FMR output selection	Same as Y1 output selection	0	☆
F6-09	AO1 output function selection	0: Running frequency 1: Set frequency 2: Output current	0	☆
F6-10	AO2 output function selection	3: Output power 4: Output voltage	0	☆
F6-11	FMP output function selection	5: Analog AI1 input 6: Analog AI2 input 7: Communication setting 8: Output torque 9: Length	0	☆

Function Code	Parameter Name	Setting Range	Default	Property
		10: Count value 11: Motor rotational speed 12: Output bus voltage(0 to 3 times of driver rated) 13: Pulse input 14: Output current 15: Output voltage(100.0% corresponds to 1000.0V) 16: Output torque (Actual value: -2 to +2 times of the rated value)		
F6-12	FMP output max-frequency	0.01KHz~100.00KHz	50.00	☆
F6-13	AO1 minimum output	-100.0% to F6-15	0.0%	☆
F6-14	Minimum corresponds to AO1 output	0.00V to 10.00V	0.00v	☆
F6-15	AO1 maximum output	F6-13 to 100.0%	100.0%	☆
F6-16	Maximum corresponds to AO1 output	0.00V to 10.00V	10.00V	☆
F6-17	AO2 minimum output	-100.0% to F6-19	0.0%	☆
F6-18	Minimum corresponds to AO2 output	0.00V to 10.00V	0.00v	☆
F6-19	AO2 maximum output	F6-17 to 100.0%	100.0%	☆
F6-20	Maximum corresponds to AO2 output	0.00V to 10.00V	10.00V	☆
F6-26	Relay 1 output delay	0.0s to 3600.0s	0.0s	☆
F6-27	Relay 2 output delay	0.0s to 3600.0s	0.0s	☆
F6-28	Y1 high level output delay	0.0s to 3600.0s	0.0s	☆
Group F7: Auxiliary Functions and Keypad Display				
F7-00	JOG running frequency	0.00 Hz to maximum frequency	6.00Hz	☆

Function Code	Parameter Name	Setting Range	Default	Property
F7-01	JOG acceleration time	0.0s to 3000.0s	10.0s	☆
F7-02	JOG deceleration time	0.0s to 3000.0s	10.0s	☆
F7-03	Acceleration time 2	0.0s to 3000.0s	10.0s	☆
F7-04	Deceleration time 2	0.0s to 3000.0s	10.0s	☆
F7-05	Acceleration time 3	0.0s to 3000.0s	10.0s	☆
F7-06	Deceleration time 3	0.0s to 3000.0s	10.0s	☆
F7-07	Acceleration time 4	0.0s to 3000.0s	10.0s	☆
F7-08	Deceleration time 4	0.0s to 3000.0s	10.0s	☆
F7-09	Jump frequency 1	0.00 Hz to maximum frequency	0.00Hz	☆
F7-10	Jump frequency 1 amplitude.	0.00 Hz to maximum frequency	0.00Hz	☆
F7-11	Jump frequency 2	0.00 Hz to maximum frequency	0.00Hz	☆
F7-12	Jump frequency 2 amplitude.	0.00 Hz to maximum frequency	0.00Hz	☆
F7-15	Forward/Reverse rotation dead-zone time.	0.0s to 3000.0s	0.0s	☆
F7-16	Keypad knob accuracy	0: Default mode 1: 0.1Hz 2: 0.5Hz 3: 1Hz 4: 2Hz 5: 4Hz	0	☆
		6: 5Hz 7: 8Hz 8: 10Hz		
F7-17	Running mode when set frequency lower than frequency lower limit.	0: Run at frequency lower limit 1: Stop 2: Run at zero speed	0	☆

Function Code	Parameter Name	Setting Range	Default	Property
F7-18	Droop ration	0.0% to 100.0%	0.0%	☆
F7-19	Delay time of stopping mode when set frequency lower than frequency lower limit.	0.0s to 600.0s	0.0s	☆
F7-20	Setting accumulative running time.	0h to 65000h	0h	☆
F7-21	JOG preferred	0: Disable 1: Enable	1	☆
F7-22	Frequency detection value (FDT1)	0.00 Hz to maximum frequency	50.00Hz	☆
F7-23	Frequency detection hysteresis (FDT hysteresis 1)	0.0% to 100.0%	5.0%	☆
F7-24	Detection range of frequency reached	0.0% to 100.0%	0.0%	☆
F7-25	Reserved		0	●
F7-26	Cooling fan control	0: Fan working continuously. 1: Fan working during running (Fan working after stopping when temperature is higher than 40 °C).	0	★
F7-27	STOP/RESET key function	0: STOP/RESET key enabled only in operation keypad control. 1: STOP/RESET key enabled in any operation mode.	1	☆
F7-28	Quick/JOG function selection	0: Forward JOG. 1: Switchover between forward rotation and reverse rotation. 2: Reverse JOG. 3: Switchover between operation keypad control and remote	0	★

Function Code	Parameter Name	Setting Range	Default	Property
		command control.		
F7-29	LED display running parameters	0000 to 0xffff Bit00: Running frequency 0001 Bit01: Set frequency 0002 Bit02: Bus voltage (V) 0004 Bit03: Output voltage 0008 Bit04: Output current 0010 Bit05: Output power (kW) 0020 Bit06: DI input status 0040 Bit07: DO output status 0080 Bit08: AI1 voltage (V) 0100 Bit09: AI2 voltage (V) 0200 Bit10: PID setting 0400 Bit11: PID feedback 0800 Bit12: Count value 1000 Bit13: Length value 2000 Bit14: load speed display 4000 Bit15: PLC stage 8000	H.441F	☆

Function Code	Parameter Name	Setting Range	Default	Property
F7-30	LED display stop parameters	1 to 0xffff Bit00: Set frequency 0001 Bit01: Bus voltage (V) 0002 Bit02: DI input status 0004 Bit03: DO output status 0008 Bit04: AI1 voltage (V) 0010 Bit05: AI2 voltage (V) 0020 Bit06: PID setting 0040 Bit07: PID feedback 0080 Bit08: Count value 0100 Bit09: Length value 0200 Bit10: Load speed display 0400 Bit11: PLC stage 0800 Bit12: Pulse input frequency 1000 Bit13~Bit15: Reserved	H.0043	☆
F7-31	Load speed display coefficient	0.001 to 65.500	1.000	☆
F7-32	Temperature of inverter module	12°C to 100°C	Measured value	●
F7-33	Accumulative power-on time	0h to 65535h	Measured value	●
F7-34	Accumulative running time	0h to 65535h	Measured value	●
F7-36	Current running time function	0: Disable 1: Enable:	0	★
F7-37	Current running time source	0: Digital setting F7-38 1: AI1 2: AI2 (100% of analog input corresponds to F8-44)	0	★

Function Code	Parameter Name	Setting Range	Default	Property
F7-38	Setting of current running time	0.0min to 6500.0min	0.0min	☆
F7-39	High level timing	0.0s to 6000.0s	2.0s	☆
F7-40	Low level timing	0.0s to 6000.0s	2.0s	☆
F7-41	Startup protection	0: No 1: Yes	1	☆
F7-43	Frequency reached detection value 1	0.00Hz to F0-14	50.00Hz	☆
F7-44	Frequency reached detection duration 1	0% to 100%	0%	☆
F7-45	Current detection level 1	0% to 300%	100%	☆
F7-46	Current reached detection duration 1	0% to 300%	0%	☆
F7-49	User code	0 to 65535	0	☆
F7-50	Jump frequency during acceleration and deceleration	0:Disable 1:Enable	0	☆
F7-51	Setting power-on reached time	0h to 65530h	0h	☆
F7-53	Frequency switchover point between acceleration time 1 and acceleration time 2	0.00Hz to maximum frequency(F0-14)	0.00Hz	☆
F7-54	Frequency switchover point between deceleration time 1 and deceleration time 2	0.00Hz to maximum frequency(F0-14)	0.00Hz	☆
F7-55	Frequency detection value (FDT2)	0.00 Hz to maximum frequency	50.00Hz	☆
F7-56	Frequency detectFDT2 hysteresis value	0.0% to 100.0%	5.0%	☆

Function Code	Parameter Name	Setting Range	Default	Property
F7-57	Frequency reached detection value 2	0.00Hz to F0-14	50.00Hz	☆
F7-58	Frequency reached detection duration 2	0% to 100%	0%	☆
F7-59	Zero current detection level	0% to 300%	10.0%	☆
F7-60	Zero current detection delay time	0% to 300%	1.0s	☆
F7-61	Current output detection amplitude	20.0% to 400.0%	200.0%	☆
F7-62	Current output detection amplitude delay time	0.00s to 300.00s	0.00s	☆
F7-63	Current detection level 2	20% to 300%	100%	☆
F7-64	Current reached detection duration 2	0.0% to 300.0%	0.0%	☆
F7-65	LED display running parameters 2	0x0~0x1FF Bit00: target torque 0001 Bit01: output torque 0002 Bit02: pulse input frequency (KHz) 0004 Bit03: HDI input liner speed(m/min) 0008 Bit04: motor rotation speed0010 Bit05: AC line current 0020 Bit06: Accumulative running time(h) Bit07: The current running time(min) Bit08: Accumulative power consumption (KW/h) Bit09~Bit15: reserved	0x00	☆

Function Code	Parameter Name	Setting Range	Default	Property
F7-67	All input voltage lower limit	0.00V to F7-68	2.00V	☆
F7-68	All input voltage upper limit	F7-67 to 11.00V	8.00V	☆
F7-69	Module temperature threshold	0°C to 90°C	70°C	☆
F7-70	Output power correction coefficient	0.001 to 3.000	1.000	☆
F7-71	Linear speed display coefficient	Linear speed = F-71 * HDI1 pulse number per second /Fb-07	1.000	☆
F7-72	Accumulative power consumption	0kW to 65535kW	Measured value	●
F7-73	Performance software version		##	●
F7-74	Function software version		##	●
F7-75	Improve function parameter display selecting	0:Hide improvement function parameter:H0~H3,L0~L5 1:Display improvement function parameter:H0~H3,L0~L5	0	☆
F7-76	Motor rotational display correction coefficient	0.0010~3.0000	1.0000	☆
Group F8: Communication Parameters				
F8-00	Baud rate	0: 300BPS 1: 600BPS 2: 1200BPS 3: 2400BPS 4: 4800BPS 5: 9600BPS	5	☆

Function Code	Parameter Name	Setting Range	Default	Property
		6: 19200BPS 7: 38400BPS		
F8-01	Data format	0: No check <8,N,2> 1: Even parity check 2 <8,E,1> 2: Odd Parity check <8,O,1> 3: No check1 <8,N,1>	0	☆
F8-02	Local address	0 to 247 (0 is Broadcast address)	1	☆
F8-03	Response delay	0ms to 30ms	2ms	☆
F8-04	Communication timeout	0.0s to 30.0s	0.0s	☆
F8-05	Communication data format selection	0: Standard MODBUS-RTU protocol 1: Nonstandard MODBUS-RTU protocol	0	☆
Group F9: Fault and Protection				
F9-00	Motor overload protection selection.	0: Disable 1: Enable	1	☆
F9-01	Motor overload protection gain.	0.02 to 10.00	1.00	☆
F9-02	Motor overload warning coefficient.	50% to 100%	80%	☆
F9-03	Overvoltage stall gain	0 to 100	30	☆
F9-04	Overvoltage stall protective voltage	200.0V to 850.0V	760.0V	★
F9-05	V/F overcurrent stall gain	0 to 100	20	☆
F9-06	V/F overcurrent stall protective current	100% to 200%	150%	★
F9-07	VF weak magnetic current stall protection coefficient.	50% to 200%	100%	★

Function Code	Parameter Name	Setting Range	Default	Property
F9-08	Overvoltage stalling allowed to rise limit value	0% to 100%	10%	☆
F9-11	Fault auto reset times	0 to 20	0	☆
F9-12	Fault relay action selection during fault auto reset	0: Not act 1: Act	0	☆
F9-13	Time interval of fault auto reset	0.1s to 100.0s	1.0s	☆
F9-14	Input phase loss protection selection	0: Disable 1: Enable	1	☆
F9-15	Output phase loss protection selection	0: Disable 1: Enable	1	☆
F9-16	Short-circuit to ground upon power-on	0: Disable 1: Enable	1	☆
F9-17	Undervoltage fault auto reset selection	0: Manual reset fault after the under voltage fault. 1: Auto reset fault according to the bus voltage after the fault.	0	☆
F9-18	Overvoltage inhibition mode selection	0: Ineffective 1: Overvoltage inhibition mode 1 2: Overvoltage inhibition mode 2	1	★
F9-19	Over excitation force state selection	0: Ineffective 1: Effective during running at constant speed or deceleration 2: Effective during running at deceleration	2	★
F9-20	Threshold of over-voltage inhibition mode 2	1.0% to 150.0%	100.0%	★
F9-22	Fault protection action selection 1	0 to 22202 Unit's digit: Motor over load – Err14 0: Coast to stop 1: Stop according to stop mode	00000	☆

Function Code	Parameter Name	Setting Range	Default	Property
		2:Continue to run Ten's digit: Reserved Hundred's digit: Input phase loss - Err23 Thousand's digit: Output phase loss - Err24 Ten thousand's digit: Parameter read-write fault – Err25		
F9-23	Fault protection action selection 2	0 to 22222 Unit's digit: Communication fault – Err27 0: Coast to stop 1: Stop according to stop mode 2:Continue to run Ten's digit: External equipment fault – Err28 Hundred's digit: Too large speed deviation – Err29 Thousand's digit: User-definedfault1 – Err30 Ten thousand's digit: User-definedfault1 – Err31	00000	☆

Function Code	Parameter Name	Setting Range	Default	Property
F9-24	Fault protection action selection 3	0 to 22022 Unit's digit: PID feedback lost during running – Err32 0: Coast to stop 1: Stop according to stop mode 2: Continue to run Ten's digit: Load becoming 0 – Err34 Hundreds place: reserved Thousands place: Current running time reached – Err39 Ten thousand's digit: Accumulative running time reached – Err40	00000	☆
F9-26	Frequency selection for continuing to run upon fault	0: Current running frequency 1: Set frequency 2: Frequency upper limit 3: Frequency lower limit 4: Backup frequency(F9-27)	1	☆
F9-27	Backup frequency upon abnormality	0.0% to 100.0%	100.0%	☆
F9-28	Protection upon load becoming 0	0: Disable 1: Enable	0	☆
F9-29	Detection level of load becoming 0	0.0% to 80.0%	20.0%	★
F9-30	Detection time of load becoming 0	0.0s to 100.0s	5.0%	☆
F9-31	Detection value of too large speed deviation	0.0% to 100.0%	20.0%	☆
F9-32	Detection time of too large speed deviation	0.0s to 100.0s	0.0s	☆
F9-33	Over-speed detection	0.0% to 100.0%	20.0%	☆

Function Code	Parameter Name	Setting Range	Default	Property
	value			
F9-34	Over-speed detection time	0.0s to 100.0s	2.0s	☆
F9-35	Motor overload protection current coefficient	100% to 200%	100%	☆
Group FA: PID Function				
FA-00	PID setting source	0: Keypad 1: AI1 2: AI2 3: Communication setting 4: Pulse setting (DI5) 5: Multi-reference	0	☆
FA-01	PID digital setting	0.0% to 100.0%	50.0%	☆
FA-02	PID setting change time	Response time:0.00s to 650.00s	0.00s	☆
FA-03	PID feedback source	0: AI1 1: AI2 2: AI1 - AI2 3: Communication setting 4: Pulse setting (DI5) 5: AI1 + AI2 6: MAX(AI1 , AI2) 7: MIN(AI1 , AI2)	0	☆
FA-04	PID action direction	0: Forward action 1: Reverse action	0	☆
FA-05	PID feedback range setting	0 to 65535	1000	☆
FA-06	Proportional gain K_p	0.0 to 100.0	20.0	☆
FA-07	Integral time T_{i1}	0.01s to 10.00s	2.00s	☆
FA-08	Differential time T_{d1}	0.000s to 10.000s	0.000s	☆
FA-09	Cut-off frequency of PID	0.00Hz to maximum	0.00Hz	☆

Function Code	Parameter Name	Setting Range	Default	Property
	reverse rotation	frequency(F0-14)		
FA-10	Deviation limit	0.0% to 100.0%	0.0%	☆
FA-11	Differential limit	0.00% to 100.00%	0.10%	☆
FA-12	PID feedback filter time	0.00s to 60.00s	0.00s	☆
FA-13	Detection value of PID feedback loss	0.0% to 100.0%	0.0%	☆
FA-14	Detection time of PID feedback loss	0.0s to 3600.0s	3600.0s	☆
FA-18	Proportional gain Kip	0.0 to 100.0	20.0	☆
FA-19	Integral time Ti1	0.01s to 10.00s	2.00s	☆
FA-20	Differential time Td1	0.000s to 10.000s	0.000s	☆
FA-21	PID parameter switchover condition	0: No switchover 1: Switchover via DI 2: Automatic switchover based on deviation	0	☆
FA-22	PID parameter switchover deviation 1	0.0% to FA-23	20.0%	☆
FA-23	PID parameter switchover deviation 2	FA-22 to 100.0%	80.0%	☆
FA-24	PID initial value	0.0% to 100.0%	0.0%	☆
FA-25	PID initial value holding time	0.00s to 650.00s	0.00s	☆
FA-26	Maximum deviation between two PID outputs in forward direction	0.00% to 100.00%	1.00%	☆
FA-27	Maximum deviation between two PID outputs in reverse direction	0.00% to 100.00%	1.00%	☆
FA-28	PID integral property	Unit's digit: Integral separated 0: Effective	00	☆

Function Code	Parameter Name	Setting Range	Default	Property
		1: Ineffective Ten's digit: integral selection when output reached limit 0:Continue 1:Stop		
FA-29	PID operation at stop	0:No PID operation at stop 1: PID operation at stop	0	☆
Group Fb: Swing Frequency, Fixed Length and Count				
Fb-00	Swing frequency setting mode	0: Relative to the central frequency 1: Relative to the maximum frequency	0	☆
Fb-01	Swing frequency amplitude	0.0% to 100.0%	0.0%	☆
Fb-02	Jump frequency amplitude	0.0% to 50.0%	0.0%	☆
Fb-03	Swing frequency cycle	0.1s to 3000.0s	10.0s	☆
Fb-04	Triangular wave rising time coefficient	0.1% to 100.0%	50.0%	☆
Fb-05	Set length	0m to 65535m	1000m	☆
Fb-06	Actual length	0m to 65535m	0m	☆
Fb-07	Number of pulses per meter	0.1 to 6553.5	100.0	☆
Fb-08	Set count value	1 to 65535	1000	☆
Fb-09	Designated count value	1 to 65535	1000	☆
Group FC: Multi-Reference and Simple PLC Function				
FC-00	Reference 0	-100.0% to 100.0%	0.0%	☆
FC-01	Reference 1	-100.0% to 100.0%	0.0%	☆
FC-02	Reference 2	-100.0% to 100.0%	0.0%	☆

Function Code	Parameter Name	Setting Range	Default	Property
FC-03	Reference 3	-100.0% to 100.0%	0.0%	☆
FC-04	Reference 4	-100.0% to 100.0%	0.0%	☆
FC-05	Reference 5	-100.0% to 100.0%	0.0%	☆
FC-06	Reference 6	-100.0% to 100.0%	0.0%	☆
FC-07	Reference 7	-100.0% to 100.0%	0.0%	☆
FC-08	Reference 8	-100.0% to 100.0%	0.0%	☆
FC-09	Reference 9	-100.0% to 100.0%	0.0%	☆
FC-10	Reference 10	-100.0% to 100.0%	0.0%	☆
FC-11	Reference 11	-100.0% to 100.0%	0.0%	☆
FC-12	Reference 12	-100.0% to 100.0%	0.0%	☆
FC-13	Reference 13	-100.0% to 100.0%	0.0%	☆
FC-14	Reference 14	-100.0% to 100.0%	0.0%	☆
FC-15	Reference 15	-100.0% to 100.0%	0.0%	☆
FC-16	Simple PLC running mode	0: Stop after the AC drive runs one cycle 1: Keep final values after the AC drive runs one cycle 2: Repeat after the AC drive runs one cycle	0	☆
FC-17	Simple PLC retentive selection	0: Non-retentive neither at power off nor after stop. 1: Retentive at power off but non-retentive after stop. 2: Non-retentive at power off but retentive after stop. 3: Retentive at power off and after stop.	0	☆
FC-18	Running time of simple PLC reference 0	0.0~6500.0	0.0	☆

Function Code	Parameter Name	Setting Range	Default	Property
FC-19	Acceleration/deceleration time of simple PLC reference 0	0 to 3 (Means acceleration/deceleration time 1 to 4 respectively)	0	☆
FC-20	Running time of simple PLC reference 1	0.0~6500.0	0.0	☆
FC-21	Acceleration/deceleration time of simple PLC reference 1	0 to 3 (Means acceleration/deceleration time 1 to 4 respectively)	0	☆
FC-22	Running time of simple PLC reference 2	0.0~6500.0	0.0	☆
FC-23	Acceleration/deceleration time of simple PLC reference 2	0 to 3 (Means acceleration/deceleration time 1 to 4 respectively)	0	☆
FC-24	Running time of simple PLC reference 3	0.0~6500.0	0.0	☆
FC-25	Acceleration/deceleration time of simple PLC reference 3	0 to 3 (Means acceleration/deceleration time 1 to 4 respectively)	0	☆
FC-26	Running time of simple PLC reference 4	0.0~6500.0	0.0	☆
FC-27	Acceleration/deceleration time of simple PLC reference 4	0 to 3 (Means acceleration/deceleration time 1 to 4 respectively)	0	☆
FC-28	Running time of simple PLC reference 5	0.0~6500.0	0.0	☆
FC-29	Acceleration/deceleration time of simple PLC reference 5	0 to 3 (Means acceleration/deceleration time 1 to 4 respectively)	0	☆
FC-30	Running time of simple PLC reference 6	0.0~6500.0	0.0	☆
FC-31	Acceleration/deceleration time of simple PLC	0 to 3	0	☆

Function Code	Parameter Name	Setting Range	Default	Property
	reference 6	(Means acceleration/deceleration time 1 to 4 respectively)		
FC-32	Running time of simple PLC reference 7	0.0~6500.0	0.0	☆
FC-33	Acceleration/deceleration time of simple PLC reference 7	0 to 3 (Means acceleration/deceleration time 1 to 4 respectively)	0	☆
FC-34	Running time of simple PLC reference 8	0.0~6500.0	0.0	☆
FC-35	Acceleration/deceleration time of simple PLC reference 8	0 to 3 (Means acceleration/deceleration time 1 to 4 respectively)	0	☆
FC-36	Running time of simple PLC reference 9	0.0~6500.0	0.0	☆
FC-37	Acceleration/deceleration time of simple PLC reference 9	0 to 3 (Means acceleration/deceleration time 1 to 4 respectively)	0	☆
FC-38	Running time of simple PLC reference 10	0.0~6500.0	0.0	☆
FC-39	Acceleration/deceleration time of simple PLC reference 10	0 to 3 (Means acceleration/deceleration time 1 to 4 respectively)	0	☆
FC-40	Running time of simple PLC reference 11	0.0~6500.0	0.0	☆
FC-41	Acceleration/deceleration time of simple PLC reference 11	0 to 3 (Means acceleration/deceleration time 1 to 4 respectively)	0	☆
FC-42	Running time of simple PLC reference 12	0.0~6500.0	0.0	☆
FC-43	Acceleration/deceleration time of simple PLC reference 12	0 to 3 (Means acceleration/deceleration time 1 to 4 respectively)	0	☆

Function Code	Parameter Name	Setting Range	Default	Property
FC-44	Running time of simple PLC reference 13	0.0~6500.0	0.0	☆
FC-45	Acceleration/deceleration time of simple PLC reference 13	0 to 3 (Means acceleration/deceleration time 1 to 4 respectively)	0	☆
FC-46	Running time of simple PLC reference 14	0.0~6500.0	0.0	☆
FC-47	Acceleration/deceleration time of simple PLC reference 14	0 to 3 (Means acceleration/deceleration time 1 to 4 respectively)	0	☆
FC-48	Running time of simple PLC reference 15	0.0~6500.0	0.0	☆
FC-49	Acceleration/deceleration time of simple PLC reference 15	0 to 3 (Means acceleration/deceleration time 1 to 4 respectively)	0	☆
FC-50	Time unit of simple PLC	0:s 1:h	0	☆
FC-51	Multi-Reference priority selection	0: No 1:Yes	1	☆
FC-52	Acceleration/deceleration time of multi-Reference	0: Acceleration/deceleration time 1 1: Acceleration/deceleration time 2 2: Acceleration/deceleration time 3 3: Acceleration/deceleration time 4	0	☆
FC-53	FC - 00 - FC - 15 units selection of multi-segment speed	0:% 1:Hz	0	☆
FC-55	Reference 0 source	0: Keypad 1: AI1 2: AI2 3: Pulse setting 4: PID 5: Set by preset frequency (F0-11,	0	☆

Function Code	Parameter Name	Setting Range	Default	Property
		modified via terminal UP/ DOWN		
Group Fd : Torque Control				
Fd-00	Torque setting source in torque control	0: Keypad 1: AI1 2: AI2 3: Pulse setting 4: Communication setting 5: MAX(AI1 , AI2) 6: MIN(AI1 , AI2) (Full range of 1 to 6 corresponds to Fd-01)	0	★
Fd-01	Torque digital setting	-200.0% to 200.0%	150.0%	☆
Fd-03	Forward maximum frequency in torque	0.00Hz to maximum frequency(F0-14)	50.00Hz	☆
Fd-04	Reverse maximum frequency in torque	0.00Hz to maximum frequency(F0-14)	50.00Hz	☆
Fd-06	Torque setting filter time	0.00s to 10.00s	0.00s	☆
Fd-07	Acceleration time in torque control	0.0s to 1000.0s	10.0s	☆
Fd-08	Deceleration time in torque control	0.0s to 1000.0s	10.0s	☆
Fd-10	Speed/Torque control	0: Speed control 1: Torque control	0	★
Group FE: AI Curve Setting				
FE-00	AI curve 1 minimum input	-10.00V to FE-02	0.00	☆
FE-01	Corresponding setting of AI curve 1 minimum input	-100.0% to 100.0%	0.0%	☆
FE-02	AI curve 1 inflexion 1 input	FE-00 to FE-04	3.00	☆
FE-03	Corresponding setting of	-100.0% to 100.0%	30.0%	☆

Function Code	Parameter Name	Setting Range	Default	Property
	AI curve 1 inflexion 1 input			
FE-04	AI curve 1 inflexion 2 input	FE-02to FE-06	6.00	☆
FE-05	Corresponding setting of AI curve 1 inflexion 2 input	-100.0% to 100.0%	60.0%	☆
FE-06	AI curve 1 maximum input	FE-06 to 10.00V	10.00	☆
FE-07	Corresponding setting of AI curve 1 maximum input	-100.0% to 100.0%	100.0%	☆
FE-08	AI curve 2 minimum input	-10.00V to FE-02	0.00V	☆
FE-09	Corresponding setting of AI curve 2 minimum input	-100.0% to 100.0%	0.0%	☆
FE-10	AI curve 2 inflexion 1 input	FE-00 to FE-04	3.00	☆
FE-11	Corresponding setting of AI curve 2 inflexion 1 input	-100.0% to 100.0%	30.0%	☆
FE-12	AI curve 2 inflexion 2 input	FE-02to FE-06	6.00	☆
FE-13	Corresponding setting of AI curve 2 inflexion 2 input	-100.0% to 100.0%	60.0%	☆
FE-14	AI curve 2 maximum input	FE-06 to 10.00V	10.00V	☆
FE-15	Corresponding setting of AI curve 2 maximum input	-100.0% to 100.0%	100.0%	☆
FE-24	Jump point of AI1 input corresponding setting	-100.0% to 100.0%	0.0%	☆
FE-25	Jump amplitude of AI1 input corresponding setting	0.0% to 100.0%	0.5%	☆
FE-26	Jump point of AI2 input corresponding setting	-100.0% to 100.0%	0.0%	☆
FE-27	Jump amplitude of AI2 input corresponding setting	0.0% to 100.0%	0.5%	☆
Group FF: Factory Parameters				
FF-00	User code	0 to 65535	*****	☆

Function Code	Parameter Name	Setting Range	Default	Property
Group H0: Motor 2 Parameters Setting				
H0-00	Motor selection	1: Motor 1 2: Motor 2	1	★
H0-01	Motor 2 control mode	1: Open loop flux vector control (Speed-sensorless vector control) 2: Voltage/Frequency (V/F) control	2	★
H0-02	Motor 2 acceleration/deceleration time	0: Same as motor 1 1: Acceleration/deceleration time 1 2: Acceleration/deceleration time 2 3: Acceleration/deceleration time 3 4: Acceleration/deceleration time 4	0	☆
Group H1: Motor 2 Parameters				
H1-00	Auto-tuning selection	0: No auto-tuning 1: Static auto-tuning 2: Complete auto-tuning	0	★
H1-01	Rated motor 2 power	0.4kW to 1000.0kW	Model dependent	★
H1-02	Rated motor 3 voltage	0V to 1500V	380V	★
H1-03	Number of pole pairs of motor 2	2 to 64	Model dependent	●
H1-04	Rated motor 2 current	0.01A to 600.00 A (motor rated power ≤30 kW) 0.1A to 6000.0 A (motor rated power >30kW)	H1-01 dependent	★
H1-05	Rated motor 2 frequency	0.00Hz to F0-14	50.00Hz	★
H1-06	Rated motor 2 rotational speed	0rpm to 30000rpm	H1-01 dependent	★
H1-07	Motor 2 no-load current	0.01A to H1-04 A (motor rated	H1-01	★

Function Code	Parameter Name	Setting Range	Default	Property
		power ≤ 30 kW) 0.1A to H1-04 A (motor rated power > 30 kW)	dependent	
H1-08	Motor 2 stator resistance	0.001 Ω to 65.535 Ω	Model dependent	★
H1-09	Motor 2 rotor resistance	0.001 Ω to 65.535 Ω	Model dependent	★
H1-10	Motor 2 mutual inductive	0.1mH to 6553.5mH	Model dependent	★
H1-11	Motor 2 leakage inductive	0.01mH to 655.35mH	Model dependent	★
H1-12	Acceleration time of complete auto-tuning	1.0s to 600.0s	10.0s	☆
H1-13	Deceleration time of complete auto-tuning	1.0s to 600.0s	10.0s	☆
Group H2: Motor 2 V/F Control Parameters				
H2-00	Torque boost	0.0%~30.0%	0.0%	☆
H2-02	Oscillation suppression gain	0 to 100	Model dependent	☆
Group H3: Motor 2 Vector Control Parameters				
H3-00	Switchover frequency 1	1.00Hz to H3-02	5.00Hz	☆
H3-02	Switchover frequency 2	H3-00 to F0-14	10.00Hz	☆
H3-04	Speed loop proportional gain at low frequency	1.0 to 10.0	4.0	☆
H3-05	Speed loop integral time at low frequency	0.01s to 10.00s	0.50s	☆
H3-06	Speed loop proportional gain at high frequency	1.0 to 10.0	2.0	☆

Function Code	Parameter Name	Setting Range	Default	Property
H3-07	Speed loop integral time at high frequency	0.01s to 10.00s	1.00s	☆
H3-08	Speed loop integral property	0: integral effect 1: integral separation	0	★
H3-11	Torque adjustment proportional gain Kp	0 to 30000	2000	☆
H3-12	Torque adjustment integral gain Ki	0 to 30000	1300	☆
H3-13	Excitation adjustment proportional gain Kp	0 to 30000	2000	☆
H3-14	Excitation adjustment integral gain Ki	0 to 30000	1300	☆
H3-15	Flux braking gain	100 to 200	110	☆
H3-16	Field weakening torque correction ratio	50% to 200%	100%	☆
H3-17	Slip compensation gain	50% to 200%	100%	☆
H3-18	Speed loop feedback filter time	0.000s to 1.000s	0.015s	☆
H3-19	Speed loop output filter time	0.000s to 1.000s	0.000s	☆
H3-20	Source of power-driven torque upper limit	0: F3-21 1: AI1 2: AI2 3: Communication setting 4: Pulse setting (DI5) (Analog range corresponds to H3-21)	0	☆

Function Code	Parameter Name	Setting Range	Default	Property
H3-21	Power-driven torque upper limit	0.0% to 200.0%	150.0%	☆
H3-22	Source of braking torque upper limit	0: F3-23 1: AI1 2: AI2 3: Communication setting 4: Pulse setting (DI5) (Analog range corresponds to H3-23)	0	☆
H3-23	Braking torque upper limit	0.0% to 200.0%	150.0%	☆
Group L0: System Parameters				
L0-00	Parameters only for reading	0: Disable 1: Enable	1	☆
L0-01	LCD top menu display	0: output current 1: motor rotation speed 2: load speed 3: output voltage 4: PID giving 5: PID feedback	0	☆
L0-02	LCD language selection	0: Chinese 1: English	0	☆
L0-03	LED menu switching selection	0: prohibition 1: enable	0	☆
L0-04	Vector running frequency display selection	0: Real-time frequency 1: setting frequency	0	☆
L0-05	UP/Down regulation display selection	0: Display the setting value 1: Display the current variable value	0	☆

Function Code	Parameter Name	Setting Range	Default	Property
Group L1: User - defined Parameters				
L1-00	Clear user-defined parameters	0: Disable 1: Enable	0	☆
L1-01	User-defined parameters 1	uF0-00 to uU1-xx	uF0-03	☆
L1-02	User-defined parameters 2	uF0-00 to uU1-xx	uF0-04	☆
L1-03	User-defined parameters 3	uF0-00 to uU1-xx	uF0-06	☆
L1-04	User-defined parameters 4	uF0-00 to uU1-xx	uF0-23	☆
L1-05	User-defined parameters 5	uF0-00 to uU1-xx	uF0-24	☆
L1-06	User-defined parameters 6	uF0-00 to uU1-xx	uF4-00	☆
L1-07	User-defined parameters 7	uF0-00 to uU1-xx	uF4-01	☆
L1-08	User-defined parameters 8	uF0-00 to uU1-xx	uF4-02	☆
L1-09	User-defined parameters 9	uF0-00 to uU1-xx	uF4-04	☆
L1-10	User-defined parameters 10	uF0-00 to uU1-xx	uF4-05	☆
L1-11	User-defined parameters 11	uF0-00 to uU1-xx	uF4-06	☆
L1-12	User-defined parameters 12	uF0-00 to uU1-xx	uF4-12	☆
L1-13	User-defined parameters 13	uF0-00 to uU1-xx	uF4-13	☆
L1-14	User-defined parameters 14	uF0-00 to uU1-xx	uF5-00	☆
L1-15	User-defined parameters 15	uF0-00 to uU1-xx	uF5-01	☆
L1-16	User-defined parameters 16	uF0-00 to uU1-xx	uF5-02	☆
L1-17	User-defined parameters 17	uF0-00 to uU1-xx	uF6-00	☆
L1-18	User-defined parameters 18	uF0-00 to uU1-xx	uF6-01	☆
L1-19	User-defined parameters 19	uF0-00 to uU1-xx	uF0-00	☆
L1-20	User-defined parameters 20	uF0-00 to uU1-xx	uF0-00	☆
L1-21	User-defined parameters 21	uF0-00 to uU1-xx	uF0-00	☆

Function Code	Parameter Name	Setting Range	Default	Property
L1-22	User-defined parameters 22	uF0-00 to uU1-xx	uF0-00	☆
L1-23	User-defined parameters 23	uF0-00 to uU1-xx	uF0-00	☆
L1-24	User-defined parameters 24	uF0-00 to uU1-xx	uF0-00	☆
L1-25	User-defined parameters 25	uF0-00 to uU1-xx	uF0-00	☆
L1-26	User-defined parameters 26	uF0-00 to uU1-xx	uF0-00	☆
L1-27	User-defined parameters 27	uF0-00 to uU1-xx	uF0-00	☆
L1-28	User-defined parameters 28	uF0-00 to uU1-xx	uF0-00	☆
L1-29	User-defined parameters 29	uF0-00 to uU1-xx	uF0-00	☆
L1-30	User-defined parameters 30	uF0-00 to uU1-xx	uF0-00	☆
L1-31	User-defined parameters 31	uF0-00 to uU1-xx	uF0-00	☆
Group L2: Optimization Parameters				
L2-00	Dead zone compensation selection	0: No compensation 1: Compensation	1	☆
L2-01	PWM modulation mode	0: Asynchronous modulation 1: Synchronous modulation	0	☆
L2-02	PWM seven phase/five phase selection	0: Seven phase in whole course 1: Seven phase/five phase auto switchover	0	☆
L2-03	CBC current limit	0: Disable 1: Enable	1	☆
L2-04	Braking threshold	350.0V to 780.0V	360.0V	☆
			690.0V	
L2-05	Under voltage threshold	200.0V to 500.0V	200.0V	☆
			350.0V	
L2-06	Random PWM depth	0 to 6	0	☆
L2-07	0Hz running way	0: No current output	0	☆

Function Code	Parameter Name	Setting Range	Default	Property
		1: Normal operation 2: Output with DC braking current F1-16		
L2-08	Limitation of low frequency carrier	0: Limitation mode 0 1: Limitation mode 1 2: Unlimited (the carrier waves are in accordance in every frequency ranges)	0	☆
Group L3: AI/AO Correction				
L3-00	AI1 displayed voltage 1	-9.999V to 10.000V	3.000V	☆
L3-01	AI1 measured voltage 1	-9.999V to 10.000V	3.000V	☆
L3-02	AI1 displayed voltage 2	-9.999V to 10.000V	8.000V	☆
L3-03	AI1 measured voltage 2	-9.999V to 10.000V	8.000V	☆
L3-04	AI2 displayed voltage 1	-9.999V to 10.000V	3.000V	☆
L3-05	AI2 measured voltage 1	-9.999V to 10.000V	3.000V	☆
L3-06	AI2 displayed voltage 2	-9.999V to 10.000V	8.000V	☆
L3-07	AI2 measured voltage 2	-9.999V to 10.000V	8.000V	☆
L3-12	AO1 target voltage 1	-9.999V to 10.000V	3.000V	☆
L3-13	AO1 measured voltage 1	-9.999V to 10.000V	3.000V	☆
L3-14	AO1 target voltage 2	-9.999V to 10.000V	8.000V	☆
L3-15	AO1 target voltage 2	-9.999V to 10.000V	8.000V	☆
L3-16	AO2 measured voltage 1	-9.999V to 10.000V	3.000V	☆
L3-17	AO2 target voltage 1	-9.999V to 10.000V	3.000V	☆
L3-18	AO2 measured voltage 2	-9.999V to 10.000V	8.000V	☆
L3-19	AO2 target voltage 2	-9.999V to 10.000V	8.000V	☆
Group L4: Master-slave Control Parameters				

Function Code	Parameter Name	Setting Range	Default	Property
L4-00	Master-slave control selection	0: Disable 1: Enable	0	★
L4-01	Master-slave selection	0: Master 1: Slave	0	★
L4-02	Master sending frequency selection	0: Running frequency 1: Target frequency	0	★
L4-03	Command source selection of slave followed the master	0: Non-follow 1: Follow	0	★
L4-04	Slave received frequency coefficient	0.00%~600.00%	100.00% <1>	☆
L4-05	Slave received torque coefficient	-10.00 to 10.00	1.00	☆
L4-06	Slave received torque offset	-50.00% to 50.00%	0.00%	☆
L4-07	Frequency offset threshold	0.20% to 10.00%	0.50%	☆
L4-08	Master-slave communication offline detection time	0.00s to 10.00s	0.10S	☆
Group L5: Braking Function Parameters				
L5-00	Braking control selection	0: Disable 1: Enable	0	★
L5-01	Braking loosen frequency	0.00Hz to 20.00Hz	2.50Hz	★
L5-02	Braking loosen frequency holding time	0.0s to 20.0s	1.0s	★
L5-03	Braking period current threshold	50.0% to 200.0%	120.0%	★
L5-04	Braking actuation	0.00Hz to 20.00Hz	1.50Hz	★

Function Code	Parameter Name	Setting Range	Default	Property
	frequency			
L5-05	Braking actuation delay time	0.0s to 20.0s	0.0s	★
L5-06	Braking actuation frequency holding time	0.0s to 20.0s	1.0s	★
Group L6: Sleep Wake-up Function Parameters				
L6-00	Sleep selection	0:Sleep function ineffective 1:DI terminal control 2:PID setting and feedback control 3: Running frequency control	0	☆
L6-01	Sleep frequency	0.00Hz to 50.00Hz	0.00Hz< 1>	☆
L6-02	Sleep delay time	0.0s to 3600.0s	20.0s	☆
L6-03	Wake-up deviation	0.0% to 100.0%	10.0%	☆
L6-04	Wake-up delay time	0.0s to 3600.0s	0.5s	☆
L6-05	Dormant delay time Frequency output selection	0:PID auto-adjustment 1: Dormant frequency L6-01	0	☆

Function Code	Parameter Name	Min. Unit	Property
Group U0: Error Recording Parameters			
U0-00	3 rd (latest) fault type	1	●
U0-01	2 nd (latest) fault type	1	●
U0-02	1 st fault type	1	●

Function Code	Parameter Name	Min. Unit	Property
	speed Err08: Overvoltage during acceleration Err09: Overvoltage during deceleration Err10: Overvoltage at constant speed Err12: Under voltage Err13: Drive overload Err14: Motor overload Err15: Drive overheat Err17: Current detection fault Err20: Short circuit to ground Err23: Power input phase loss Err24: Power output phase loss Err25: EEPROM read-write fault Err27: Communication fault Err28: External equipment fault Err29: Too large speed deviation Err30: User-definedfault1 Err31: User-definedfault2 Err32: PID feedback lost during running Err33: Fast current limit fault Err34: Load becoming 0 Err35: Control power supply fault Err37: Control power supply fault Err39: Current running time reached Err40: Accumulative running time reached Err42: Motor switchover fault		

Function Code	Parameter Name	Min. Unit	Property
	during running Err46: Master slave control communication disconnection		
U0-03	Frequency upon the 3 rd fault	0.01Hz	●
U0-04	Current upon the 3 rd fault	0.01A	●
U0-05	Bus voltage upon the 3 rd fault	0.1V	●
U0-06	DI status upon the 3 rd fault	1	●
U0-07	Output terminal status upon the 3 rd fault	1	●
U0-08	AC drive status upon the 3 rd fault	1	●
U0-09	Power-on time upon the 3 rd fault	1min	●
U0-10	Running time upon the 3 rd fault	1min	●
U0-13	Frequency upon the 2 nd fault	0.01Hz	●
U0-14	Current upon the 2 nd fault	0.01A	●
U0-15	Bus voltage upon the 2 nd fault	0.1V	●
U0-16	DI status upon the 2 nd fault	1	●
U0-17	Output terminal status upon the 2 nd fault	1	●
U0-18	AC drive status upon the 2 nd fault	1	●
U0-19	Power-on time upon the 2 nd fault	1min	●
U0-20	Running time upon the 2 nd fault	1min	●
U0-21	Reserved		●
U0-22	Reserved		●
U0-23	Frequency upon the 1 st fault	0.01Hz	●
U0-24	Current upon the 1 st fault	0.01A	●
U0-25	Bus voltage upon the 1 st fault	0.1V	●

Function Code	Parameter Name	Min. Unit	Property
U0-26	DI status upon the 1 st fault	1	●
U0-27	Output terminal status upon the 1 st fault	1	●
U0-28	AC drive status upon the 1 st fault	1	●
U0-29	Power-on time upon the 1 st fault	1min	●
U0-30	Running time upon the 1 st fault	1min	●
Group U1: Application Monitoring Parameters			
U1-00	Running frequency	0.01Hz	●
U1-01	Setting frequency	0.01Hz	●
U1-02	Bus voltage	0.1V	●
U1-03	Output voltage	1v	●
U1-04	Output current	0.1A	●
U1-05	Output power	0.1kW	●
U1-06	DI input status, hexadecimal	1	●
U1-07	DO output status, hexadecimal	1	●
U1-08	AI1 voltage after correction	0.01V	●
U1-09	AI2 voltage after correction	0.01V	●
U1-10	PID setting, PID setting (percentage)×FA-05	1	●
U1-11	PID feedback, PID feedback (percentage)×FA-05	1	●
U1-12	Count value	1	●
U1-13	Length value	1	●
U1-14	Motor speed	1rpm	●
U1-15	PLC stage	1	●
U1-16	Input pulse frequency	0.01kHz	●

Function Code	Parameter Name	Min. Unit	Property
U1-17	Feedback speed	0.1Hz	●
U1-18	Remaining running time of F7-38 setting	0.1min	●
U1-19	AI1 voltage before correction	0.001v	●
U1-20	AI2 voltage before correction	0.001v	●
U1-21	HDI5 high speed pulse sampling linear speed	1m/min	●
U1-22	Load speed display	1rpm	●
U1-23	Current power-on time	1min	●
U1-24	Current running time	0.1min	●
U1-25	Pulse input frequency	1Hz	●
U1-26	Communication setting value	0.01%	●
U1-27	Main frequency X	0.01Hz	●
U1-28	Auxiliary frequency Y	0.01Hz	●
U1-29	Target torque	0.1%	●
U1-30	Output torque	0.1%	●
U1-31	Output torque	0.1%	●
U1-32	Torque upper limit	0.1%	●
U1-33	Target voltage upon V/F separation	1V	●
U1-34	Output voltage upon V/F separation	1V	●
U1-35	Reserved		●
U1-36	Current motor number	1	●
U1-37	AO1 target voltage	0.01V	●
U1-38	AO2 target voltage	0.01V	●
U1-39	AC drive running status: 0:Stop	1	●

Function Code	Parameter Name	Min. Unit	Property
	1: Forward 2: Reverse 3: Fault		
U1-40	AC drive current fault	1	●
U1-41	Agent remaining limited time	1h	●
U1-42	AC input current	0.1A	●
U1-43	PLC current stage remaining time	0.1	●
U1-47	Accumulative running time 1 (Accumulative running time=U1-47+U1-48)	1h	●
U1-48	Accumulative running time 2 (Accumulative running time=U1-47+U1-48)	1min	●